

Iwaki Air Pump

APN-110

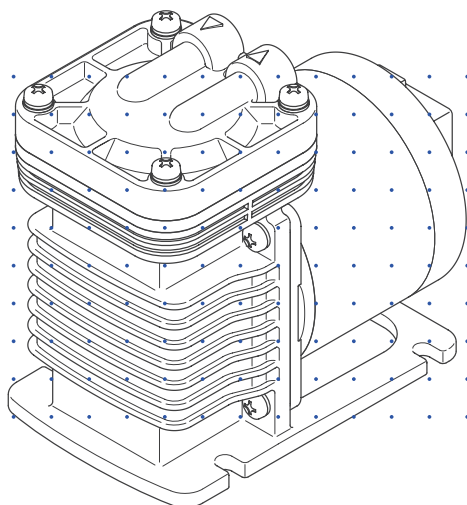

Instruction manual

Thank you for choosing our product.



Please read through this instruction manual before use.



This instruction manual describes important precautions and instructions for the product. Always keep it on hand for quick reference.

Order confirmation

Open the package and check that the product conforms to your order. If any problem or inconsistency is found, immediately contact your distributor.

a. Check if the delivery is correct.

Check the nameplate to see if the information such as model codes, discharge capacity and discharge pressure are as ordered.

Iwaki Air Pump 	
MODEL	
MAX.CAPACITY	ℓ/min
MAX.PRESSURE	MPa
MAX.VACUUM	kPa
VOLTAGE	V
CURRENT	A
POWER CONSUMPTION	W
FREQUENCY	Hz 
INDOOR USE ONLY Year	
MFG.No.	
IWAKI CO.,LTD. MADE IN JAPAN	
6-6,Kanda-Sudacho 2-chome Chiyoda-ku Tokyo Japan	

3P-006468

b. Check if the delivery is damaged or deformed.

Check for transit damage and loose bolts.

Contents

Order confirmation	2
<i>Safety instructions</i>	<i>5</i>
WARNING.....	6
CAUTION.....	7
Precautions for use	9
<i>Overview.....</i>	<i>12</i>
Introduction.....	12
Pump structure & Operating principle	12
Part names.....	13
Identification codes.....	14
<i>Installation</i>	<i>15</i>
Pump mounting.....	15
Pipework	16
Tube connection	16
Wiring.....	17
Power voltage/Earthing	17
<i>Operation.....</i>	<i>18</i>
Pump operation	18
Operation	18
Before a long period of stoppage (1 week or more)	19

<i>Maintenance</i>	20
Troubleshooting	20
Inspection	22
Daily inspection	22
Wear part replacement	23
Wear part list.....	23
Before service.....	23
Diaphragm replacement	24
Valve replacement	25
Specification/Outer dimension	26
Specification	26
Pump	26
Motor	26
Outer dimension	27
APN-110	27
APN-P110.....	28
APN-S110.....	28
Performance curves	29
APN-110	29
APN-P110.....	29
APN-S110.....	29
Part names & Structure	30
APN-110	30
APN-P110.....	31
APN-S110.....	32

Safety instructions

Read through this section before use. This section describes important information for you to prevent personal injury or property damage.

■ Symbols

In this instruction manual, the degree of risk caused by incorrect use is noted with the following symbols. Please pay attention to the information associated with the symbols.



WARNING

Indicates mishandling could lead to a fatal or serious accident.



CAUTION

Indicates mishandling could lead to personal injury or property damage.

A symbol accompanies each precaution, suggesting the use of "Caution", "Prohibited actions" or specific "Requirements".

Caution marks



Caution



Electrical shock

Prohibition marks



Prohibited



Do not rework or alter

Requirement marks



Requirement



Wear protection



Grounding



Export Restrictions

Technical information contained in this instruction manual might be treated as controlled technology in your countries, due to agreements in international regime for export control.

Please be reminded that export license/permission could be required when this manual is provided, due to export control regulations of your country.

WARNING

Turn off power before service

Risk of electrical shock. Be sure to turn off power to stop the pump and related devices before service is performed.



Stop operation

If you notice any abnormal or dangerous conditions, suspend operation immediately and inspect/solve problems.



Do not use the pump in any condition other than its intended purpose

The use of the pump in any conditions other than those clearly specified may result in failure or injury. Use this product in a specified conditions only.



Do not modify the pump

Alterations to the pump carries a high degree of risk. It is not the manufacturer's responsibility for any failure or injury resulting from alternations to the pump.



Use specified power only

Do not apply power other than that specified on the nameplate. Otherwise, failure or fire may result. Ensure the pump is properly grounded.



Wear protective clothing

Always wear protective clothing such as an eye protection, chemical resistant gloves, a mask and a face shield during disassembly, assembly or maintenance work. The specific solution will dictate the degree of protection. Refer to MSDS precautions from the solution supplier.



Do not damage a power cable

Do not pull, knot or crush the power cable. Damage to the power cable could lead to a fire or electrical shock if cut or broken.



! CAUTION**Qualified personnel only**

The pump should be handled or operated by qualified personnel with a full understanding of the pump. Any person not familiar with the product should not take part in the operation or maintenance of the pump.



Requirement

Keep electric parts and wiring dry

Risk of fire or electric shock. Install the pump where it can be kept dry.



Prohibited

Ventilation

Fumes or vapours can be hazardous with certain solutions. Ensure proper ventilation at the operation site.



Caution

Do not install/store the pump:

- In a flammable atmosphere.
- In a dusty/humid environment.
- Where operating (or storage) temperature can fall below 5°C (or 0°C) or exceed 40°C.



Prohibited

Spill precautions

Ensure protection and containment of solution in the event of plumbing or pump damage (secondary containment).



Requirement

Do not use the pump in a wet location

The pump is not waterproof. Use of the pump in wet or extremely humid locations could lead to electric shock or short circuit.



Prohibited

Grounding

Risk of electrical shock! Always properly ground the pump. Conform to local electric codes.



Grounding

Do no use a damaged power cable

Risk of fire or electric shock. The cable is not replaceable. The whole pump unit needs to be replaced when the cable is damaged.



Install a GFCI (earth leakage breaker)

An electrical failure of the pump may adversely affect other devices on the same line. Purchase and install a GFCI (earth leakage breaker) separately.



Preventative maintenance

Follow instructions in this manual for replacement of wear parts. Do not disassemble the pump beyond the extent of the instructions.



Do not use a damaged pump

Use of a damaged pump could lead to an electric shock or death.



Disposal of a used pump

Dispose of any used or damaged pump in accordance with local rules and regulations. If necessary, consult a licensed industrial waste disposal company.



Precautions for use

- Electrical work should be performed by a qualified electrician. Otherwise, personal injury or property damage may result.



- Do not install the pump in a place where the pump can get wet. Avoid using wet gas, or internal condensation will build up and consequently result in the short lives of the valve and diaphragm.

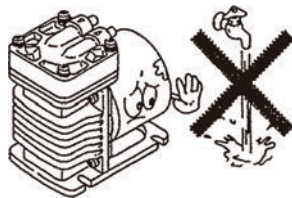

- Do not use the pump in a dusty place. Be sure to provide the inlet with a filter to prevent foreign matters from getting into the pump. Otherwise, the pump performance may reduce or the lives of the valve and diaphragm remarkably shorten.



- Do not install the pump in a corrosive or flammable gas atmosphere. Keep good ventilation in a working area. Ambient temperature should not fall below 5°C or exceed 40°C. Observe the allowable gas temperature range of 0 and 40°C.

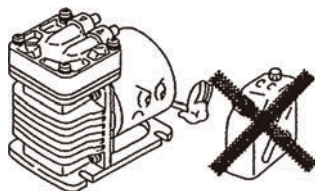

- If the compressed air (higher pressure than atmospheric pressure) is transferred to the pump, sharp deterioration to the lives of the valve, diaphragm and bearing may result. Always keep atmospheric or lower pressure in the suction line.



Do not increase suction line pressure

- Do not tube two or more pumps in series. It may prevent the motor from starting and lead to a burn out.

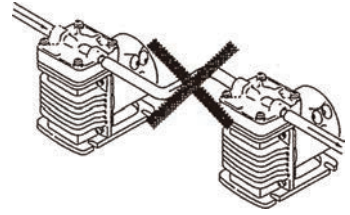

- Injection point must be below the pump position. Or siphon action or back flow may result.

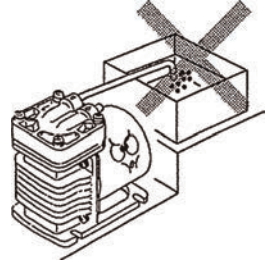

- Use care handling the pump. Do not drop. An impact may affect pump performance. Do not use a pump that has been damaged to avoid the risk of electrical damage or shock.

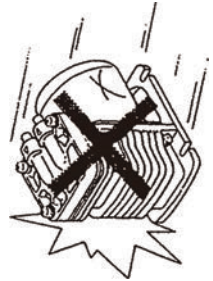

- Do not apply power other than that specified on the nameplate. Otherwise, failure or fire may result.

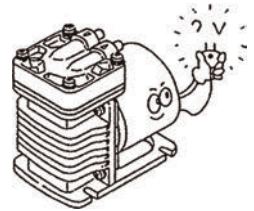

- The pump can not start with full discharge/suction pressure. Remove pressure before operation. After a long period of stoppage, pump performance at the beginning of operation becomes occasionally unstable. In this case, warm the pump up for 10 minutes with no discharge line pressure.



- Risk of burning. A pump and a pipe surface temperature rises high along with liquid temperature. Do not touch the pump or pipe surface directly during operation or right after operation.

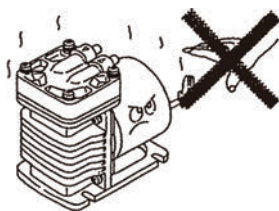

- Always use a suction valve to adjust an air flow.

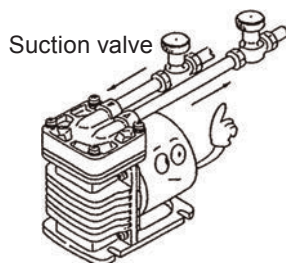

- The APN-S110 is designed for vacuum application only. Do not pressurize the discharge line of the pump.

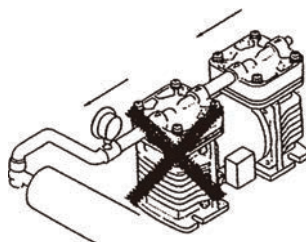

- Do not clean the pump or nameplate with a solvent such as benzene, thinner or kerosene. This may discolour the pump or erase printing. Use a dry or damp cloth or a neutral detergent.

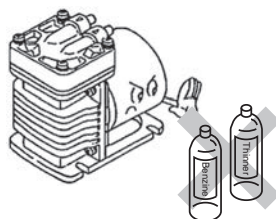

- When an earth leakage breaker is used and it has blown, always solve the root cause of blowout. Be sure to unplug the power cable before investigation.



Overview

Pump characteristics, features and part names are described in this section.

Introduction

Pump structure & Operating principle

The APN-110 is a diaphragm type air pump with a AC motor.

The rotary motion of the motor is converted through a connecting rod to the reciprocation of the diaphragm in the pump chamber, where gas is transferred from the inlet to outlet.

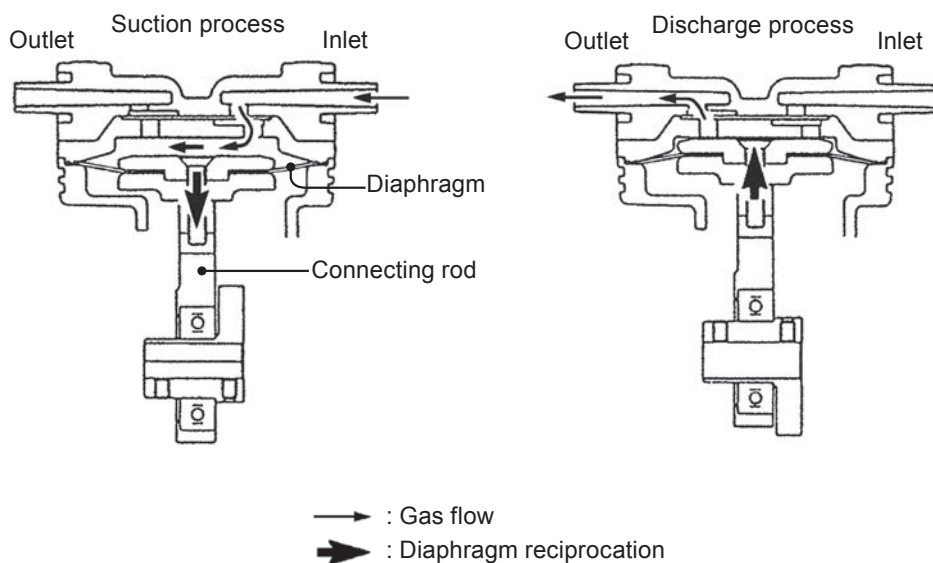

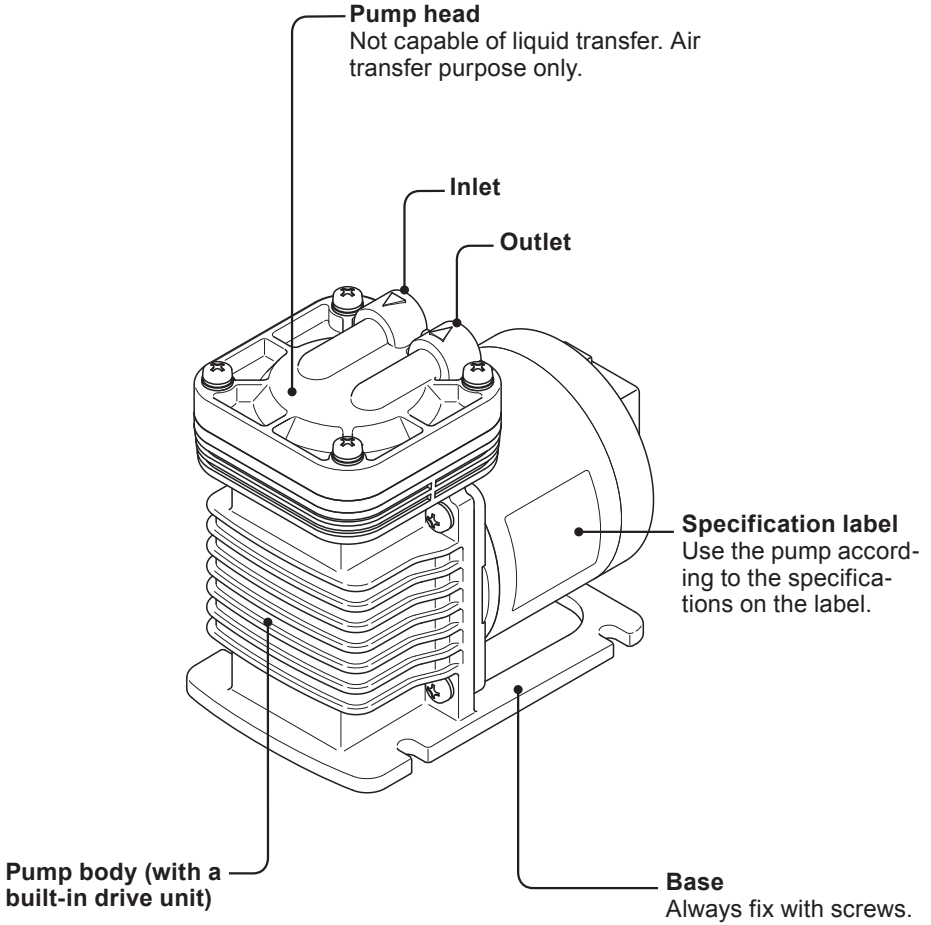

Identification codes

The model code represents the following information.

APN - S 110 K V X - 1 - 02
 a b c d e f g

a. Pump head

- No code : Single head
- S : Dual-head with series tubing
- P : Dual-head with parallel tubing

b. Pump size

c. Inlet/outlet

- K : Parallel type
- L : In-line type

d. Diaphragm/Valve materials

- V : FKM
- E : EPDM

e. Pump connection

- No code : ø8 tube connection
- X : Rc1/4 female thread connection
- X1 : G1/4 female thread connection

f. Power voltage

- 1 : 100VAC
- 2 : 200VAC
- 3 : 115VAC
- 4 : 220/240VAC
- E4 : 220/240VAC (3-core cabtyre cable)

g. Special specification

Installation

This section describes the installation of the pump, tubing and wiring. Read through this section before work.

! Observe the following points

- Risk of electrical shock. Be sure to turn off power to stop the pump and related devices before service is performed.
- If you notice any abnormal or dangerous conditions, suspend operation immediately and inspect/solve problems.
- Do not operate the pump in a flammable atmosphere.

Pump mounting

1 Select a suitable place.

See the Precautions for use section before installation.

2 Anchor the pump.

Use suitable bolts or screws.

NOTE

Do not install the pump on an unstable place.

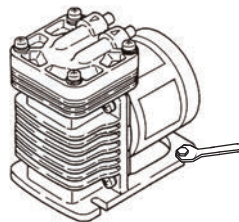

Pipework

Connect tubes to the pump.

Before operation

- Cut the tube ends flat.

Tube end (Side view)



Tube connection

a. The short tubing with the minimum bends is optimal to reduce resistance.

- b. Use vinyl tubes resistant to the pumping pressure. Tube I.D. should be equal to the O.D. of the pump inlet/outlet for the prevention of gas ingress/leak or other failure.

*Do not have tubing bent or pressed. Otherwise, the tube end may break.

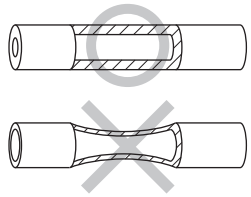

1 Connect tubes into the inlet and outlet.

Push the tubes into the inlet and outlet as far as they will go.

*If suction line connection is imperfect, the pump entrains air and it prevents the pump from bringing out full performance.

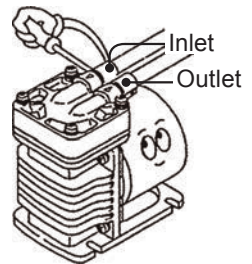

2 Valve mounting

Install a valve in the suction line for adjusting an air flow.

Wiring for power source and earthing.

! Observe the following points

- Electrical work should be performed by a qualified electrician. Conform to local electric codes.
- Do not apply power other than that specified on the nameplate. Otherwise, failure or fire may result.
- Do not perform wiring work while power is on. Otherwise, an electrical shock or short circuit may result, and consequently the pump may fail. Be sure to turn off power before service is performed.
- Be careful for electric power not to be turned on during work.

Power voltage/Earthing

Check that the main power is turned off.

1 Connect power cable via crimp contacts.

2 Earth the pump.
Be sure to earth the pump.

Operation

The pump becomes ready after pipework and wiring is completed.

Pump operation

Before operation

- a. Check that the pump is firmly fixed on a mounting position.
- b. Check that a suction tube is connected to the inlet and a discharge tube is connected to the outlet.
*If a suction line and a discharge line are connected the other way around, pumping process is inverted.
- c. Check that every tube connection is secured.
- d. Check that electrical wiring is properly done without the possibility of short-circuit and protected by an fuse.
- e. Check that power voltage that is specified on the nameplate is applied to the pump.

Operation

1 Open the suction and discharge lines.

2 Turn on power.

Operation may occasionally be upset when starting temperature is low. Warm up the pump under no load operation (a few minutes).

3

After the pump has reached a specified stroke rate, initiate full scale operation.

- Always adjust an air flow by a suction valve.
- In case electric power has failed while the pump is running, switch off main power. Otherwise, the motor may not restart or may burn out depending on a line pressure at the time of power recovery.

4

After starting, check a pressure gauge to see if suction and discharge line pressure are correct and an air flow meter to see if the specified air flow is obtained.

Before a long period of stoppage (1 week or more)

Release pressure from the pump/tubing and turn off the main power. Keep the inside of the pump head free from residual gas.

Do not store the pump:

- In a flammable/corrosive atmosphere.
- In a dusty/humid environment.
- In direct sunlight or wind & rain.
- Under vibration.
- Where ambient temperature can exceed 0-40°C.

Maintenance

This section describes troubleshooting, inspection, wear part replacement, exploded views and specifications.

! Observe the following points

- Follow instructions in this manual for replacement of wear parts. Do not disassemble the pump beyond the extent of the instructions.
- Always wear protective clothing such as an eye protection, chemical resistant gloves, a mask and a face shield during disassembly, assembly or maintenance work.
- Risk of electrical shock. Be sure to turn off power to stop the pump and related devices before service is performed.

Troubleshooting

If you notice any abnormal or dangerous conditions, suspend operation immediately and check the following points. If the following measures do not help remove problems, contact your nearest distributor.

States	Possible causes	Solutions
The pump does not run.	Power voltage is too low.	• Observe the allowable voltage range.
	The pump is not powered.	• Check the pump is switched on if any. • Correct wiring. • Replace a breaking wire to new one.
	Wrong tubing or poor connection	• Check and fix tubing.
	Diaphragm fixing screw is loose.	• Tighten the screw.
	Eccentric shaft has worn.	• Replace the connecting rod unit. Contact us.
	Connecting rod bearing has worn.	• Replace the connecting rod unit. Contact us.
	Motor trouble (a breaking wire, capacitor failure or bearing damage)	• Replace the motor. Contact us.
	Suction line pressure is compressed and is higher than atmospheric pressure.	• Keep it lower than atmospheric pressure.

Pump operation unintentionally stops.	Power voltage is too low.	<ul style="list-style-type: none"> • Observe the allowable voltage range.
	Suction line pressure is higher than atmospheric pressure.	<ul style="list-style-type: none"> • Keep it lower than atmospheric pressure.
	Discharge line pressure is higher than the maximum.	<ul style="list-style-type: none"> • Observe the maximum discharge pressure. • For the APN-S type, its outlet must be open to atmosphere.
	Connecting rod bearing has worn.	<ul style="list-style-type: none"> • Replace the connecting rod unit. Contact us.
	Motor trouble (a breaking wire, capacitor failure or bearing damage)	<ul style="list-style-type: none"> • Replace the motor. Contact us.
An air flow rate and a discharge pressure are too low.	Wrong tubing or poor connection	<ul style="list-style-type: none"> • Check and fix tubing.
	Pump head mounting screws are loose.	<ul style="list-style-type: none"> • Tighten the screws.
	Diaphragm fixing screw is loose.	<ul style="list-style-type: none"> • Tighten the screw.
	Diaphragm is broken.	<ul style="list-style-type: none"> • Replace the diaphragm.
	Filter is clogged.	<ul style="list-style-type: none"> • Clean the filter.
	Valve has worn.	<ul style="list-style-type: none"> • Replace the valve.
	Front cover fixing screws are loose.	<ul style="list-style-type: none"> • Tighten the screws.
Significant noise	Power voltage is too low.	<ul style="list-style-type: none"> • Observe the allowable voltage range.
	Pump head mounting screws are loose.	<ul style="list-style-type: none"> • Tighten the screws.
	Diaphragm fixing screw is loose.	<ul style="list-style-type: none"> • Tighten the screw.
	Diaphragm is broken.	<ul style="list-style-type: none"> • Replace the diaphragm.
	Front cover fixing screws are loose.	<ul style="list-style-type: none"> • Tighten the screws.
	Eccentric shaft has worn.	<ul style="list-style-type: none"> • Replace the connecting rod unit. Contact us.
	Connecting rod bearing has worn.	<ul style="list-style-type: none"> • Replace the connecting rod unit. Contact us.
	Motor trouble (bearing damage)	<ul style="list-style-type: none"> • Replace the motor. Contact us.

Inspection

Perform daily and periodic inspections to keep pump performance and safety.

Daily inspection

Check the following points every day. If you notice any abnormal or dangerous conditions, suspend operation immediately and remove problems according to "Troubleshooting".

When wear parts come to the life limit, replace them by new ones. Contact your distributor for detail.

No.	States	Points to be checked
1	Pumping	• If the specified power voltage & starting current are observed.
		• If the suction and discharge pressure are normal.
2	Noise and vibration	• If abnormal noise or vibration occurs. They are signs of abnormal operation.
3	Gas ingress/leak from pump head joints and a suction line	• Check lines for a leak and retighten as necessary.

Wear part replacement

To run the pump for a long period, wear parts need to be replaced periodically. It is recommended that the following parts are always stocked for immediate replacement. Contact your nearest distributor for detail.

Wear part list

If pump performance has remarkably reduced, replace diaphragms and valves with new ones.

Application	Estimated life	
	Valve	Diaphragm
APN-110	8000hr	8000hr
APN-P110		
APN-S110		

*Wear part duration varies with the pressure, temperature and characteristics of gas.

*The estimated life above is calculated based on continuous operation at the rated voltage, 20°C ambient temperature at 20°C gas.

*The estimated life above changes with operating conditions and is not warranted.

Before service

Depressurize the pump system before service.

- 1 Turn off power to stop the pump.
- 2 Open both the suction- and discharge-line valves or remove the pump from tubing system.

Diaphragm replacement

- 1 Unscrew all the pump head fixing screws.**

Take out the pump head, valve and valve seat.

- 2 Remove the diaphragm fixing screw and detach the retainer plate and diaphragm.**

- 3 Place a new diaphragm and the retainer plate onto the under retainer plate.**

- 4 Secure the retainer plate and diaphragm.**

Apply the LOCTITE® 222 to the diaphragm fixing screw and tighten it by $1.96\text{N}\cdot\text{m}$.

- 5 Push down the diaphragm until it bottoms out.**

Mount and secure the valve seat, valve and pump head onto the bracket with the screws by $1.96\text{N}\cdot\text{m}$.

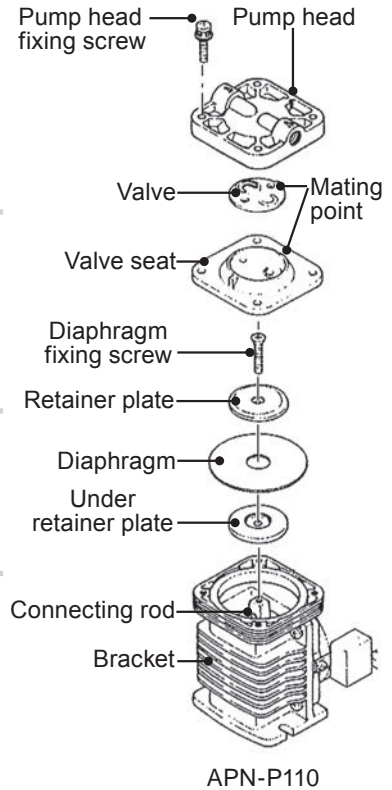

Valve replacement

1 Unscrew the pump head fixing screws.

Take out the pump head, valve and valve seat. See page 24 for detail.

2 Replace the old valve with new one.

Always check the mating points and fit the valve and the pump head in place.

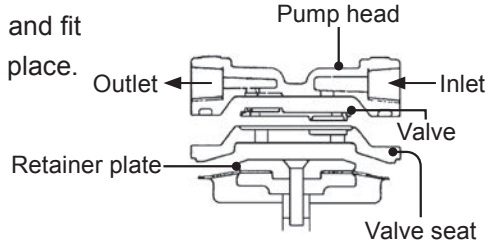

3 Supply air into the pump head unit.

Check the air flows from the inlet to the outlet.

4 Push down the diaphragm until it bottoms out.

Secure the pump head unit onto the bracket with the fixing screws by $1.96\text{N}\cdot\text{m}$.

NOTE

- Do not loosen the bracket-motor fixing screws during maintenance work.
- Contact your nearest distributor for the replacement of the connecting rod, eccentric shaft and the motor.

Specification/Outer dimension

Specification

Information in this section is subject to change without notice.

■ Pump

50/60Hz

Model code	Max air flow	Max discharge pressure	Max vacuum	Connection		Weight	Lowest starting temp.
				Tube	Thread		
APN-110 KV/LV	12/14 L/min	0.10 MPa	24.00 kPa	ø8xø5	Rc1/4	2.5kg	5°C
APN-110 KE/LE							
APN-P110 KV/LV	24/28 L/min					3.8kg	
APN-P110 KE/LE							
APN-S110 LV	12/14 L/min	-	8.00 kPa				
APN-S110 LE							

■ Motor

Model code	Input power				Output power 100/115/200 /220/240V	Power current			
	100V	115V	200V	220/240V		100V	115V	200V	220/240V
APN-110KV/LV	42/42W (50/60Hz)	44W (60Hz)	44/44W (50/60Hz)	48W (50Hz)	10W	0.50/0.44A (50/60Hz)	0.42A (60Hz)	0.25/0.22A (50/60Hz)	0.23A (50Hz)
APN-110KE/LE									
APN-P110KV/LV	60/66W (50/60Hz)	60W (60Hz)	66/74W (50/60Hz)	66W (50Hz)	25W	0.76/0.70A (50/60Hz)	0.64A (60Hz)	0.40/0.41A (50/60Hz)	0.36A (50Hz)
APN-P110KE/LE									
APN-S110LV									
APN-S110LE									

*Observe the maximum allowable discharge pressure of 0.1MPa (10kgf/cm²).

*The APN-S110 type is designed for vacuum application only with an open-ended discharge line.

*Allowable gas temperature range is 0-40°C.

*Allowable ambient temper range is 5-40°C.

*The max air flow, discharge pressure and vacuum are based on the operation with ambient air of 20°C and may change with gas/room temperature.

*Allowable maximum noise level is 50dB at 1m (A scale).

Parts \ Model	KV/LV	KE/LE
Pump head	GFRPP	
Diaphragm	FKM	EPDM
Reed valve		
Valve seat	GFRPP	
Retainer plate	GFRPPS	
Screw	Stainless steel	

GFRPP : Glass fiber reinforced polypropylene

FKM : Fluorine-contained rubber

EPDM : Ethylene propylene diene monomer

GFRPPS : Glass fiber reinforced polypropylene sulfide

Outer dimension

■ APN-110

mm

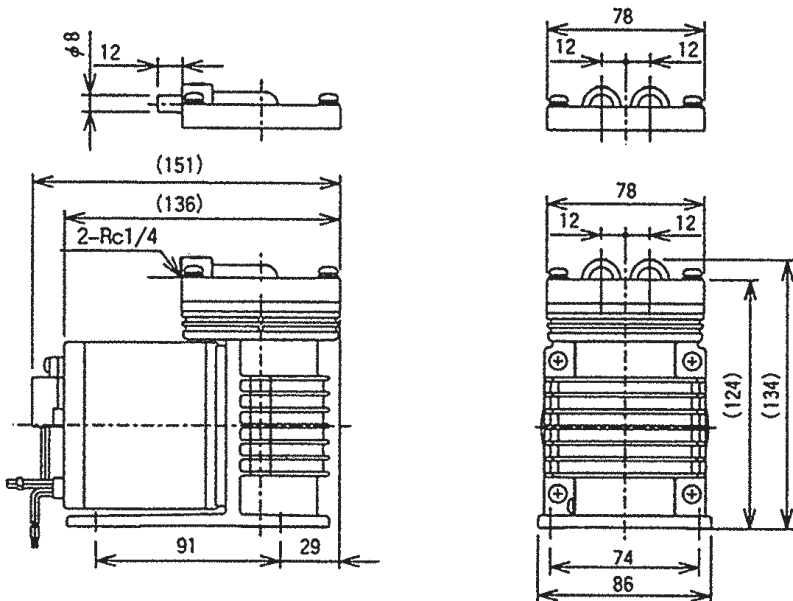

■ APN-P110

mm

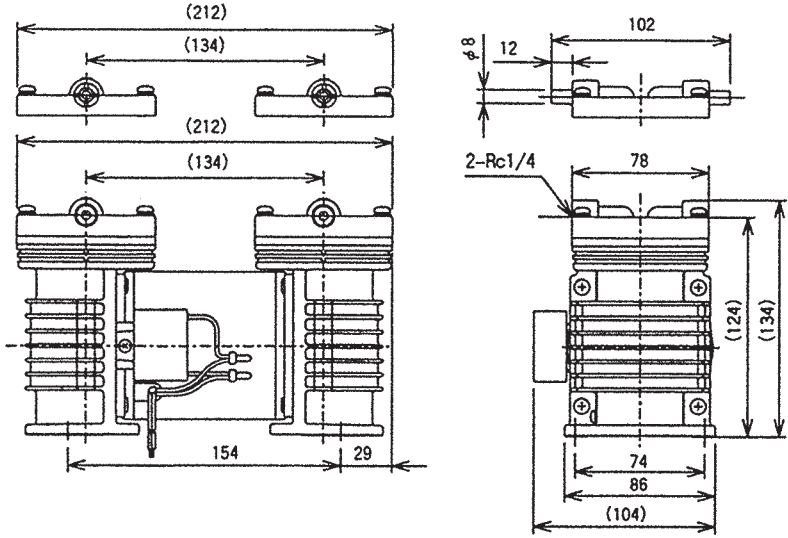

■ APN-S110

mm

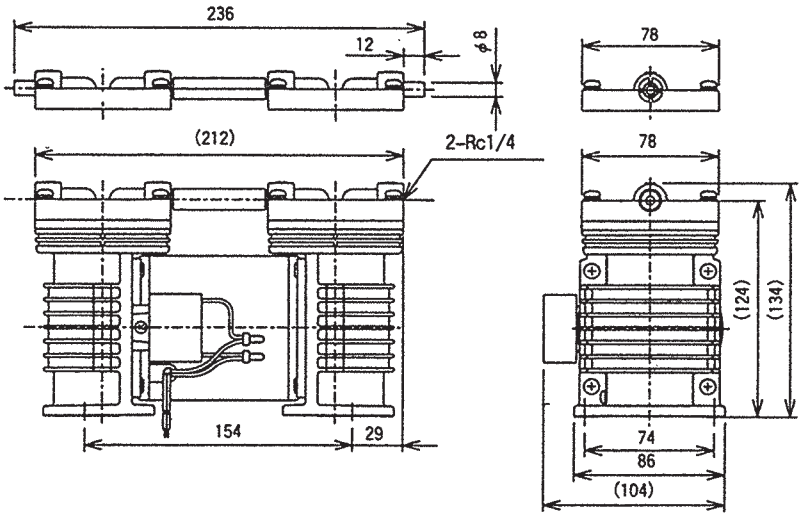

Performance curves

■ APN-110

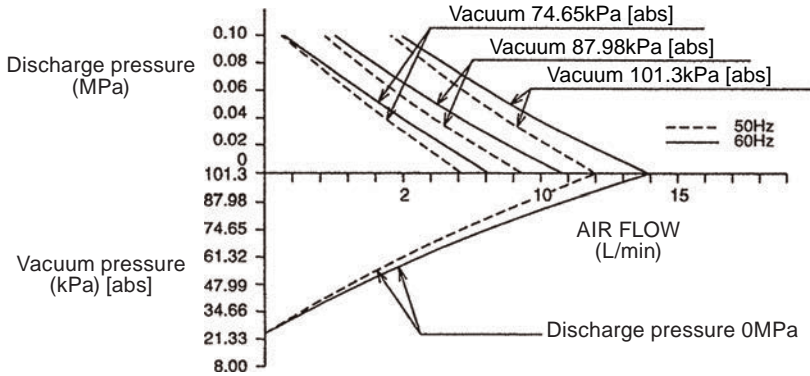

■ APN-P110

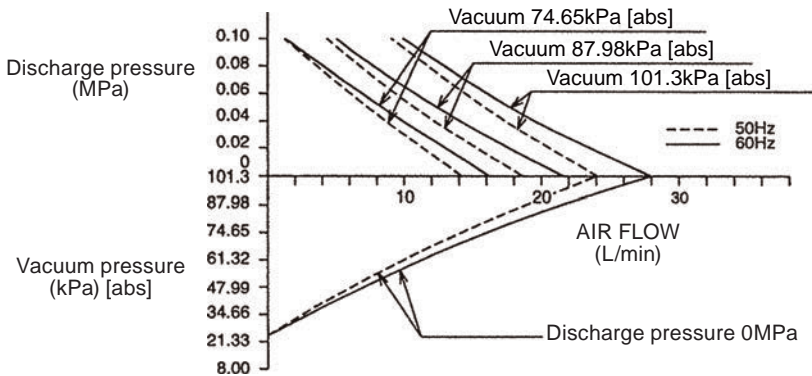

■ APN-S110

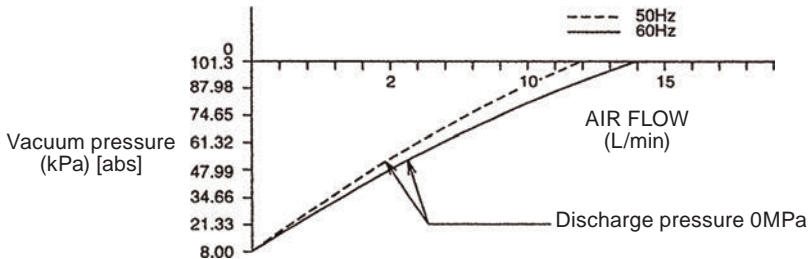

Part names & Structure

■ APN-110

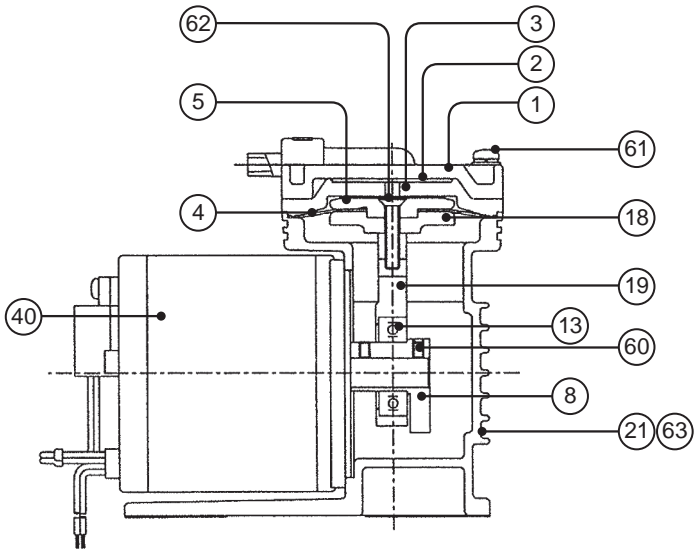

No.	Part names	Q'ty
1	Pump head	1
2	Valve	1
3	Valve seat	1
4	Diaphragm	1
5	Retainer plate	1
8	Eccentric shaft	1
13	Bearing	1
18	Under retainer plate	1

No.	Part names	Q'ty
19	Connecting rod	1
21	Bracket	1
32	Con rod unit	1
40	Motor	1
60	Set screw	2
61	Screw with washer	4
62	Screw	1
63	Screw with washer	4

■ APN-P110

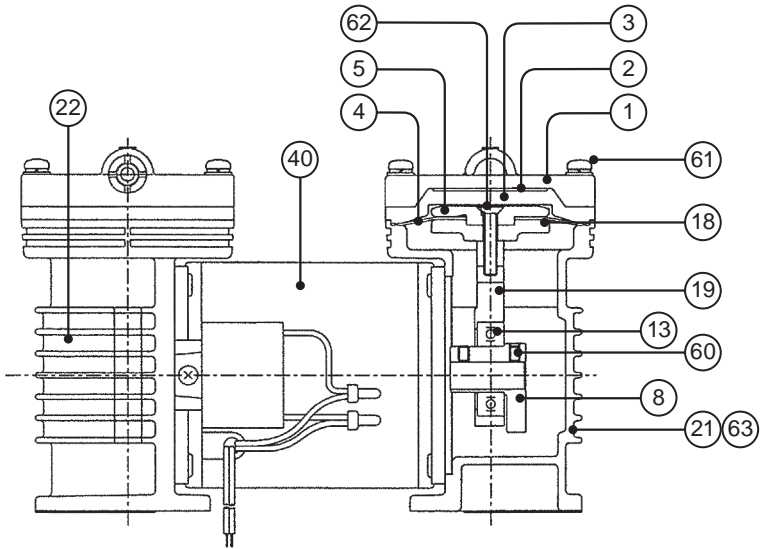

No.	Part names	Q'ty
1	Pump head	2
2	Valve	2
3	Valve seat	2
4	Diaphragm	2
5	Retainer plate	2
8	Eccentric shaft	2
13	Bearing	2
18	Under retainer plate	2

No.	Part names	Q'ty
19	Connecting rod	2
22	Bracket	2
32	Con rod unit	2
40	Motor	1
60	Set screw	2
61	Screw with washer	4
62	Screw	2
63	Screw with washer	4

■ APN-S110

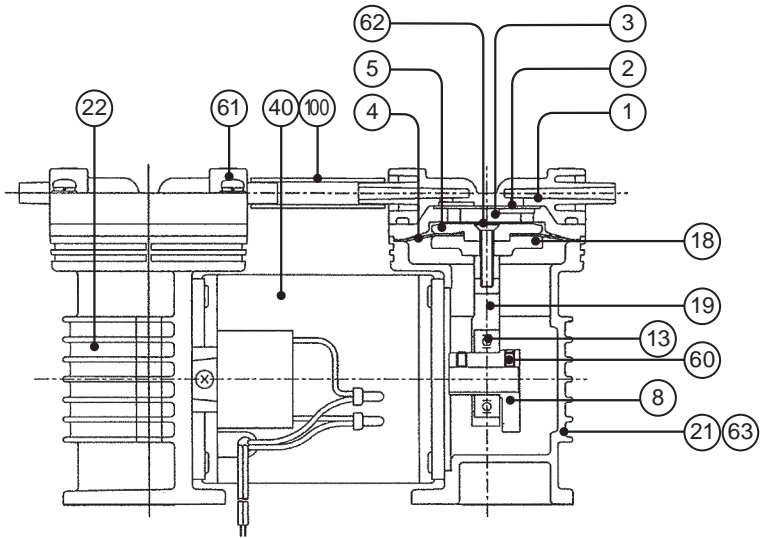

No.	Part names	Q'ty
1	Pump head	2
2	Valve	2
3	Valve seat	2
4	Diaphragm	2
5	Retainer plate	2
8	Eccentric shaft	2
13	Bearing	2
18	Under retainer plate	2
19	Connecting rod	2

No.	Part names	Q'ty
22	Bracket	2
32	Con rod unit	2
40	Motor	1
60	Set screw	4
61	Screw with washer	8
62	Screw	2
63	Screw with washer	8
100	Hose	1

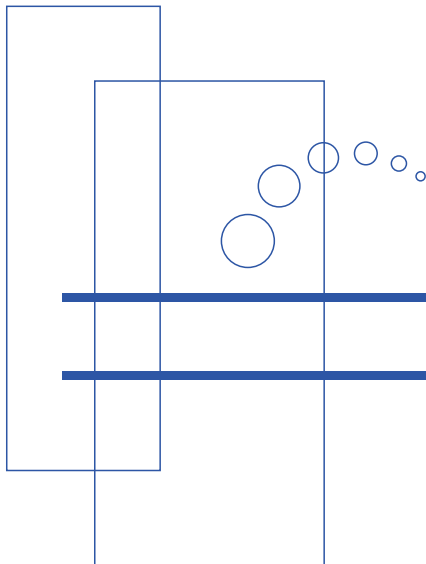

<http://www.iwakupumps.jp>

()Country codes

IWAKI CO.,LTD. 6-6 Kanda-Sudacho 2-chome Chiyoda-ku Tokyo 101-8558 Japan
TEL:(81)3 3254 2935 FAX:3 3252 8892(<http://www.iwakupumps.jp>)

Australia	IWAKI Pumps Australia Pty. Ltd.	TEL: (61)2 9899 2411	FAX: 2 9899 2421	Italy	IWAKI Europe GmbH, Italy Branch	TEL: (39)0444 371115	FAX: 0444 335350
Austria	IWAKI EUROPE GmbH	TEL: (49)2154 92540	FAX: 2154 9254 48	Korea	IWAKI Korea Co.,Ltd.	TEL: (82)2 2630 4800	FAX: 2 2630 4801
Belgium	IWAKI Belgium n.v.	TEL: (32)1367 0200	FAX: 1367 2030	Malaysia	IWAKIm Sdn. Bhd.	TEL: (60)3 7803 8807	FAX: 3 7803 4800
China	IWAKI Pumps (Shanghai) Co., Ltd.	TEL: (86)21 6272 7502	FAX: 21 6272 6929	Norway	IWAKI Norge AS	TEL: (47)23 38 49 00	FAX: 23 38 49 01
China	IWAKI Pumps (Guangdong) Co., Ltd.	TEL: (86)750 3866228	FAX: 750 3866278	Singapore	IWAKI Singapore Pte. Ltd.	TEL: (65)6316 2028	FAX: 6316 3221
China	GFTZIWAKI Engineering & Trading (Guangzhou)	TEL: (86)20 8435 0603	FAX: 20 8435 9181	Spain	IWAKI Europe GmbH, Spain Branch	TEL: (34)93 37 70 198	FAX: 93 47 40 991
China	GFTZIWAKI Engineering & Trading (Beijing)	TEL: (86)10 6442 7713	FAX: 10 6442 7712	Sweden	IWAKI Sverige AB	TEL: (46)8 511 72900	FAX: 8 511 72922
Denmark	IWAKI Nordic A/S	TEL: (45)48 24 2345	FAX: 48 24 2346	Switzerland	IP Service SA	TEL: (41)26 674 9300	FAX: 26 674 9302
Finland	IWAKI Suomi Oy	TEL: (358)9 2745810	FAX: 9 2742715	Taiwan	IWAKI Pumps Taiwan Co., Ltd.	TEL: (886)2 8227 6900	FAX: 2 8227 6818
France	IWAKI France S.A.	TEL: (33)1 69 63 33 70	FAX: 1 64 49 92 73	Taiwan	IWAKI Pumps Taiwan (Hsin-chuj) Co., Ltd.	TEL: (886)3 573 5797	FAX: (886)3 573 5798
Germany	IWAKI EUROPE GmbH	TEL: (49)2154 92540	FAX: 2154 9254 48	Thailand	IWAKI (Thailand) Co.,Ltd.	TEL: (66)2 322 2471	FAX: 2 322 2477
Holland	IWAKI Europe GmbH, Netherlands Branch	TEL: (31)74 2420011	FAX: 2154 9254 48	U.K.	IWAKI Pumps (UK) LTD.	TEL: (44)1743 231363	FAX: 1743 366507
Hong Kong	IWAKI Pumps Co., Ltd.	TEL: (852)2 607 1168	FAX: 2 607 1000	U.S.A.	IWAKI AMERICA Inc	TEL: (1)508 429 1440	FAX: 508 429 1386
Indonesia	IWAKI Singapore (Indonesia Branch)	TEL: (62)21 690 6606	FAX: 21 690 6612	Vietnam	IWAKI Pumps Vietnam Co.,Ltd.	TEL: (84)613 933456	FAX: 613 933399