

# Iwaki

## Electromagnetic Metering Pump

### EHN-NAE (multi-tube connection)

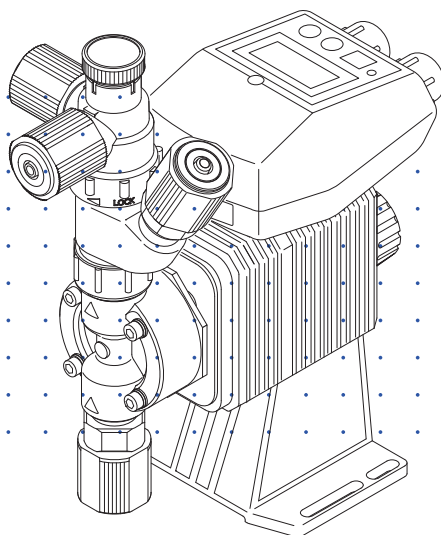

## Instruction manual

Thank you for choosing our product.



Please read through this instruction manual before use.

This instruction manual describes important precautions and instructions for the product. Always keep it on hand for quick reference.

## Order confirmation

Open the package and check that the product conforms to your order. If any problem or inconsistency is found, immediately contact your distributor.

### **a. Check if the delivery is correct.**

Check the nameplate to see if the information such as model codes, discharge capacity and discharge pressure are as ordered.

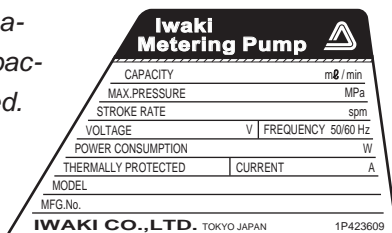

### **b. Check accessories are complete.**

- A CAN check valve

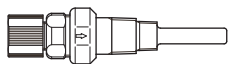

- A 3m PVC braided tube

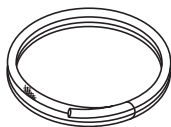

### **c. Check if the delivery is damaged or deformed.**

Check for transit damage and loose bolts.

# Contents

<b>Order confirmation</b> .....	2
<i>Safety instructions</i> .....	6
<b>Warning</b> .....	7
<b>Caution</b> .....	8
<b>Precautions for use</b> .....	10
<i>Overview</i> .....	12
<b>Introduction</b> .....	12
Pump structure & Operating principle .....	12
Auto degassing system.....	13
Features.....	14
<b>Operational functions</b> .....	14
Manual mode .....	14
<b>EXT mode</b> .....	15
Multiplier setting .....	15
Divisor setting.....	15
Control functions.....	16
Stop function .....	16
<b>Part names</b> .....	17
Pump.....	17
Operational panel .....	18
Basic display & Pump states .....	19
<b>Identification codes</b> .....	20
Pump/Drive units .....	20
Control unit .....	21

*Installation* ..... 22

**Pump mounting**..... 22

**Plumbing**..... 23

Tube connection ..... 23

Check valve mounting ..... 25

**Wiring**..... 28

Power voltage/Earthing ..... 28

Signal wire connection..... 30

*Operation*..... 34

**Before operation**..... 34

Points to be checked ..... 34

Retightening of pump head fixing bolts ..... 34

Degassing..... 35

Flow rate adjustment ..... 38

Stroke rate adjustment ..... 39

Stroke length adjustment.....41

Before a long period of stoppage (one month or more).....42

**Operation programming** ..... 43

Programming flow..... 44

Manual operation ..... 46

EXT operation.....47

EXT mode .....47

EXT mode setting..... 49

STOP function ..... 58

STOP function setting ..... 58

STOP function cancellation..... 60

Keypad lock ..... 62

Keypad lock activation..... 63

Keypad lock release ..... 63

**Troubleshooting..... 65**

**Inspection..... 67**

Daily inspection .....67

Periodic inspection .....67

**Wear part replacement..... 68**

Wear part list..... 68

Before replacement ..... 69

Valve set replacement ..... 69

Discharge valve set disassembly/assembly..... 69

Suction valve set disassembly/assembly .....71

Spacer set disassembly/assembly .....72

Auto vent valve set disassembly/assembly .....73

Diaphragm replacement ..... 74

**Exploded view.....76**

Pump head, Drive unit & Control unit .....76

Pump head ..... 77

EHN-B/-C \_ VC/VH..... 77

EHN-B/-C \_ PP .....75

Check valve .....78

**Specifications/Outer dimensions ..... 79**

Specifications .....79

Pump unit .....79

Control unit..... 80

Power cable..... 80

Pump colour ..... 80

Check valve .....81

Outer dimensions..... 82

EHN-B11/-B16 VC/VH-NAE..... 82

EHN-C16/-C21 VC/VH-NAE..... 82

# Safety instructions

Read through this section before use. This section describes important information for you to prevent personal injury or property damage.

## ■ Symbols

In this instruction manual, the degree of risk caused by incorrect use is noted with the following symbols. Please pay attention to the information associated with the symbols.



**WARNING**

Indicates mishandling could lead to a fatal or serious accident.



**CAUTION**

Indicates mishandling could lead to personal injury or property damage.

A symbol accompanies each precaution, suggesting the use of "Caution", "Prohibited actions" or specific "Requirements".

### Caution marks



Caution



Electrical shock

### Prohibited mark



Prohibited



Do not rework or alter

### Requirement mark



Requirement



Wear protection



Grounding



## Export Restrictions

Technical information contained in this instruction manual might be treated as controlled technology in your countries, due to agreements in international regime for export control.

Please be reminded that export license/permission could be required when this manual is provided, due to export control regulations of your country.

**! WARNING****Turn off power before service**

Risk of electrical shock. Be sure to turn off power to stop the pump and related devices before service is performed.



Electrical shock

**Stop operation**

If you notice any abnormal or dangerous conditions, suspend operation immediately and inspect/solve problems.



Requirement

**Do not use the pump in any condition other than its intended purpose**

The use of the pump in any conditions other than those clearly specified may result in failure or injury. Use this product in specified conditions only.



Prohibited

**Do not modify the pump**

Alterations to the pump carries a high degree of risk. It is not the manufacturer's responsibility for any failure or injury resulting from alterations to the pump.



Do not rework or alter

**Wear protective clothing**

Always wear protective clothing such as an eye protection, chemical resistant gloves, a mask and a face shield during disassembly, assembly or maintenance work. The specific solution will dictate the degree of protection. Refer to MSDS precautions from the solution supplier.



Wear protection

**Do not damage the power cable**

Do not pull, knot, or crush the power cable. Damage to the power cable could lead to a fire or electrical shock if cut or broken.



Prohibited

**Do not operate the pump in a flammable atmosphere**

Do not place explosive or flammable material near the pump.



Prohibited

## CAUTION

### Qualified personnel only

The pump should be handled or operated by qualified personnel with a full understanding of the pump. Any person not familiar with the product should not take part in the operation or maintenance of the pump.



Requirement

### Use specified power only

Do not apply power other than that specified on the nameplate. Otherwise, failure or fire may result. Ensure the pump is properly grounded.



Prohibited

### Do not run pump dry

Do not run pump dry for more than 30 minutes (even when the pump runs for degassing). Otherwise, the pump head fixing screws may loosen and liquid may leak. Optimise your system. If the pump runs dry for a long period (for more than 30 minutes), the pump head and the valve cases may deform by friction heat and consequently leakage results.



Caution

### Keep electric parts and wiring dry

Risk of fire or electric shock. Install the pump where it can be kept dry.



Prohibited

### Ventilation

Fumes or vapours can be hazardous with certain solutions. Ensure proper ventilation at the operation site.



Caution

### Do not install /store the pump:

- In a flammable atmosphere or a dusty/humid environment.
- Where ambient temperature can exceed 0-40°C.
- In direct sunlight or wind & rain.



Prohibited

### Spill precautions

Ensure protection and containment of solution in the event of plumbing or pump damage (secondary containment).



Requirement



---

**Do not use the pump in a wet location**

The pump is not waterproof. Use of the pump in wet or extremely humid locations could lead to electric shock or short circuit.



Prohibited

---

**Grounding**

Risk of electrical shock! Always properly ground the pump. Conform to local electric codes.



Grounding

---

**Install a GFCI (earth leakage breaker)**

An electrical failure of the pump may adversely affect other devices on the same line. Purchase and install a GFCI (earth leakage breaker) separately.



Electrical shock

---

**Preventative maintenance**

Follow instructions in this manual for replacement of wear parts. Do not disassemble the pump beyond the extent of the instructions.



Requirement

---

**Do not use a damaged pump**

Use of a damaged pump could lead to an electric shock or death.



Prohibited

---

**Disposal of a used pump**

Dispose of any used or damaged pump in accordance with local rules and regulations. If necessary, consult a licensed industrial waste disposal company.



Requirement

---

**Check pump head bolts**

Liquid may leak if any of the pump head bolts become loose.

Tighten the bolts diagonally and evenly by 2.16 N•m before initial operation and at regular intervals.



Caution

## Precautions for use

- Electrical work should be performed by a qualified electrician. Otherwise, personal injury or property damage could result.



- Do not install the pump:
  - In a flammable atmosphere.
  - In a dusty/humid place.
  - In direct sunlight or wind & rain.
  - Where ambient temperature can exceed 0-40°C.Protect the pump with a cover when installing it out of doors.

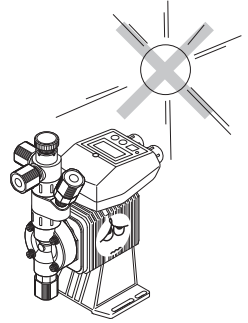

- Select a level location, free from vibration, that won't hold liquid. Anchor the pump with four M5 bolts so it doesn't vibrate. If the pump is not installed level, output may be affected.

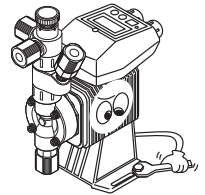

- When two or more pumps are installed together, vibration may be significant, resulting in poor performance or failure. Select a solid foundation (concrete) and fasten anchor bolts securely to prevent vibration during operation.



- Allow sufficient space around the pump for easy access and maintenance.



- Install the pump as close to the supply tank as possible.



- When handling liquids that generate gas bubbles (sodium hypochlorite or hydrazine solution), install the pump in a cool and dark place. Flooded suction installation is strongly recommended.



- Use care handling the pump. Do not drop. An impact may affect pump performance. Do not use a pump that has been damaged to avoid the risk of electrical damage or shock.



- The pump has a rating of IP66 equivalent, but is not waterproof. Do not operate the pump while wet with solution or water. Failure or injury may result. Immediately dry off the pump if it gets wet.



- Do not close discharge line during operation. Solution may leak or piping may break. Install a relief valve to ensure safety and prevent damaged plumbing.



- Do not use the control unit to a different drive unit of other pumps. An electrical circuit or the drive unit may fail.



- Solution in the discharge line may be under pressure. Release the pressure from the discharge line before disconnecting plumbing or disassembly of the pump to avoid solution spray.



- Wear protective clothing when handling or working with pumps. Consult solution MSDS for appropriate precautions. Do not come into contact with residual solution.



- Do not clean the pump or nameplate with a solvent such as benzine or thinner. This may discolor the pump or erase printing. Use a dry or damp cloth or a neutral detergent.



# Overview

Pump characteristics, features and part names are described in this section.

## Introduction

### ***Pump structure & Operating principle***

The EHN series is a diaphragm metering pump which consists of a pump head, a drive unit, and a control unit. A diaphragm is directly driven by electro-magnetic force.

#### **Principle of operation**

The pulse signal via the PCB generates the electromagnetic force to make reciprocating motion with the assistance of the spring force. The reciprocating motion is transferred to the diaphragm through the plunger and then volumetric change occurs in the pump head. This action transfers liquid along with pump head valve action.

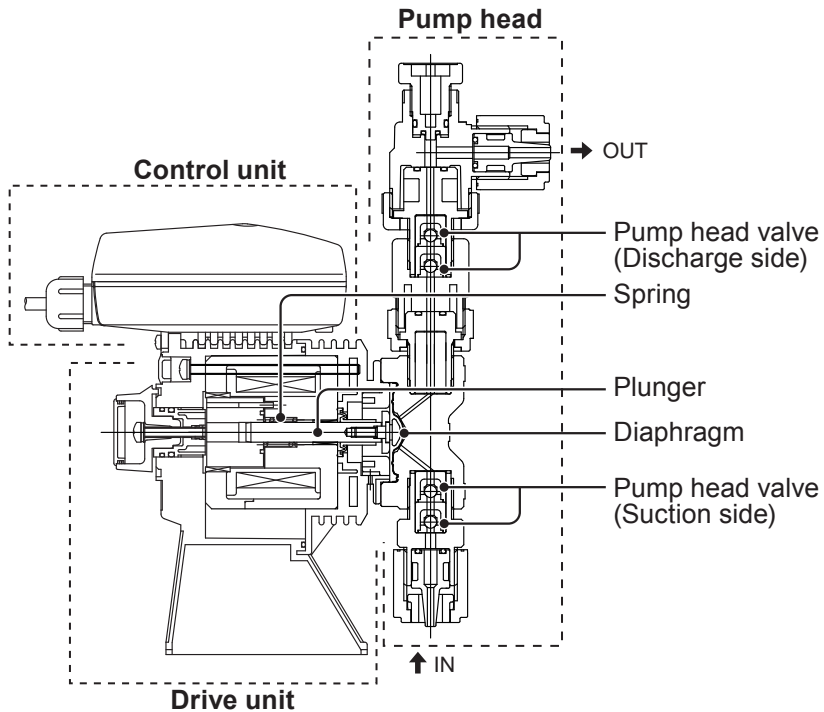

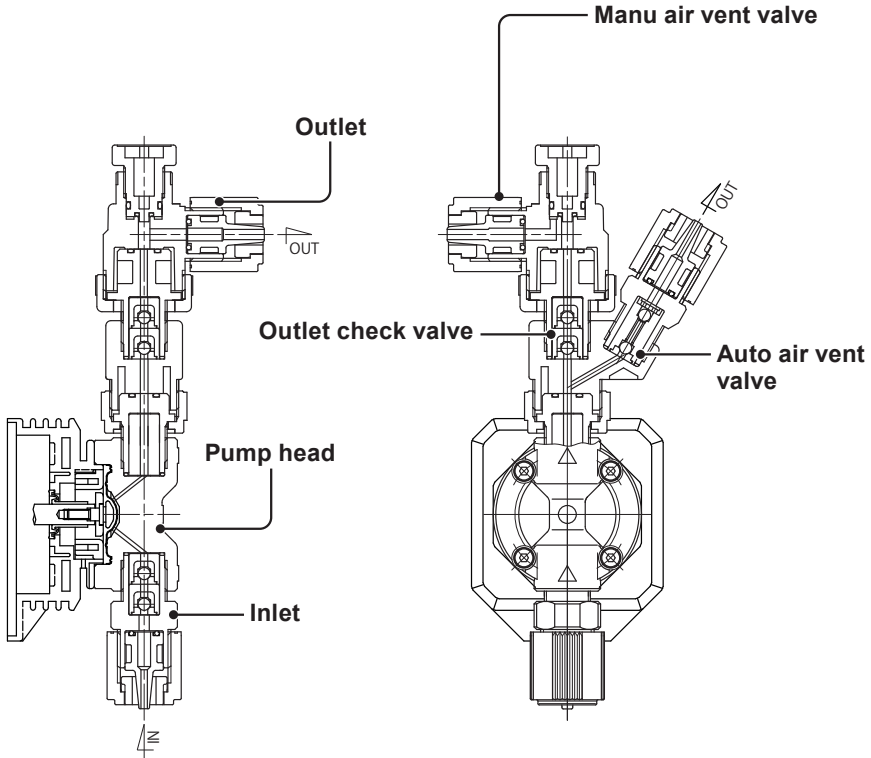

## Principle of operation

The lower opening pressure (open air pressure) of the auto vent valves than the outlet check valves lead the entrained gas to the open air via the branched air vent route. Once all gas in the pump head is expelled, liquid starts to flow the main path to the outlet.

### NOTE

---

Liquid pressure is released from the auto air vent line in the form of solution spray when it has exceeded the opening pressure of the auto air vent valve. The solution spray can occurs any time during operation. Be sure to route back the end of the auto air vent line to a supply tank or a container.

---

## Features

---

- **Multivoltage operation**

The EHN-NAE series is a multivoltage type (100-240VAC) and can be selected without local power limitations.

- **High turndown ratio**

A wide range, digitally-controlled, turndown ratio of 1-360spm with fine flow tuning (stroke length adjustment)

- **IP66 rating**

The sealed unit design assures a rating of IP66.

\*The pump has a rating of IP66 equivalent, but is not waterproof. Protect the pump with a cover when installing it out of doors.

## Operational functions

### Manual mode

---

*Run/stop the pump by the start/stop key. A stroke rate (MAN speed) can be changed in the range of 1-360spm by the up and down keys at any time during operation or stop. See page 46 for detail.*

\*The pump can also be turned ON/OFF by switching the main power.

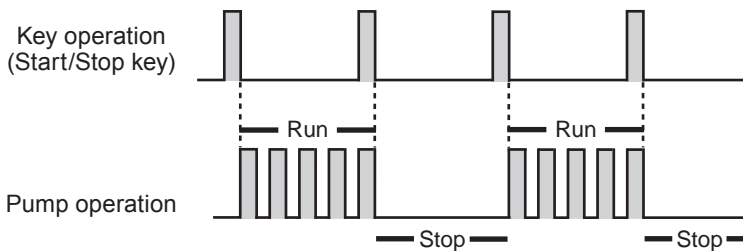

## EXT mode

### ■ Multiplier setting

The pump increases/decreases a stroke rate by the external signal and the multiplier. Set a multiplier (1-999 shots) per pulse in advance of operation. See page 50 as well.

\*In the EXT control with a preset multiplier, the pump does not run over the MAN speed at any pulse rate.

\*The pump makes one shot per pulse when the multiplier is set to 1.

Example) When the multiplier is programmed to 5, the pump makes five shots per signal.

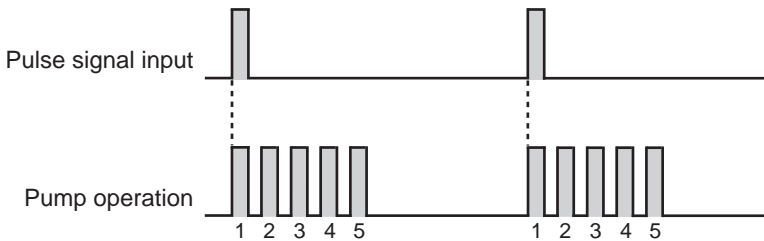

The buffer stores extra pulse signals which are entered before the scheduled shots per signal are completed.

\*Extra pulses are stored up to 255 pulses.

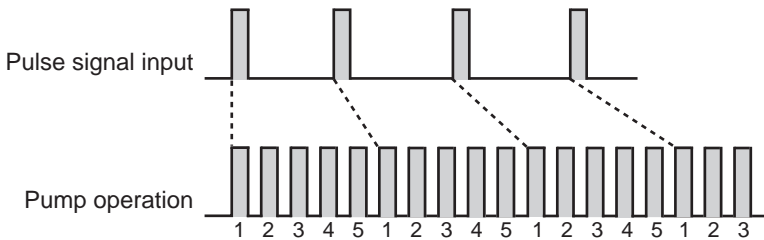

### ■ Divisor setting

The pump increases/decreases a stroke rate by the external signal and the divisor. Set a divisor (1-999 pulse rates) per shot in advance of operation. See page 52 as well.

\*In the EXT control with a preset divisor, the pump does not run over the MAN speed at any pulse rate.

\*The pump makes one shot per pulse when the divisor is set to 1.

Example) When a divisor is programmed to 5, the pump makes one shot every 5 signals.

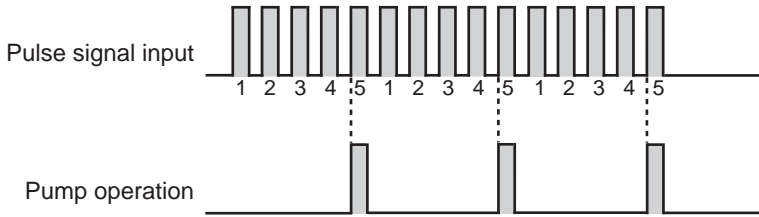

## Control functions

### ■ STOP function

The start/stop of the pump can be controlled by external devices such as a level sensor.

#### When "M-OFF" is selected:

The pump stops while receiving the external signal via the STOP terminal (closed circuit).

\*The pump resumes operation when the STOP signal is released.

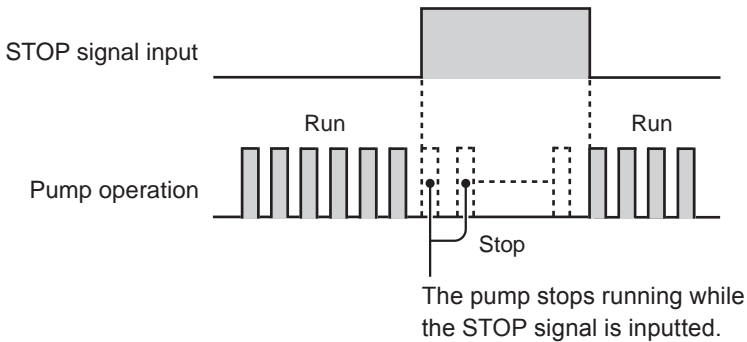

#### When "M-ON" is selected:

The pump runs while receiving the external signal via the STOP terminal (closed circuit).

\*The pump stops operation when the STOP signal is released.

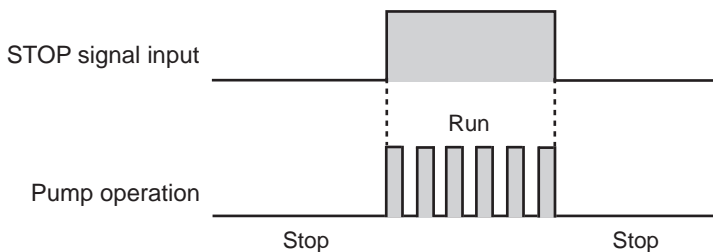



## Pump

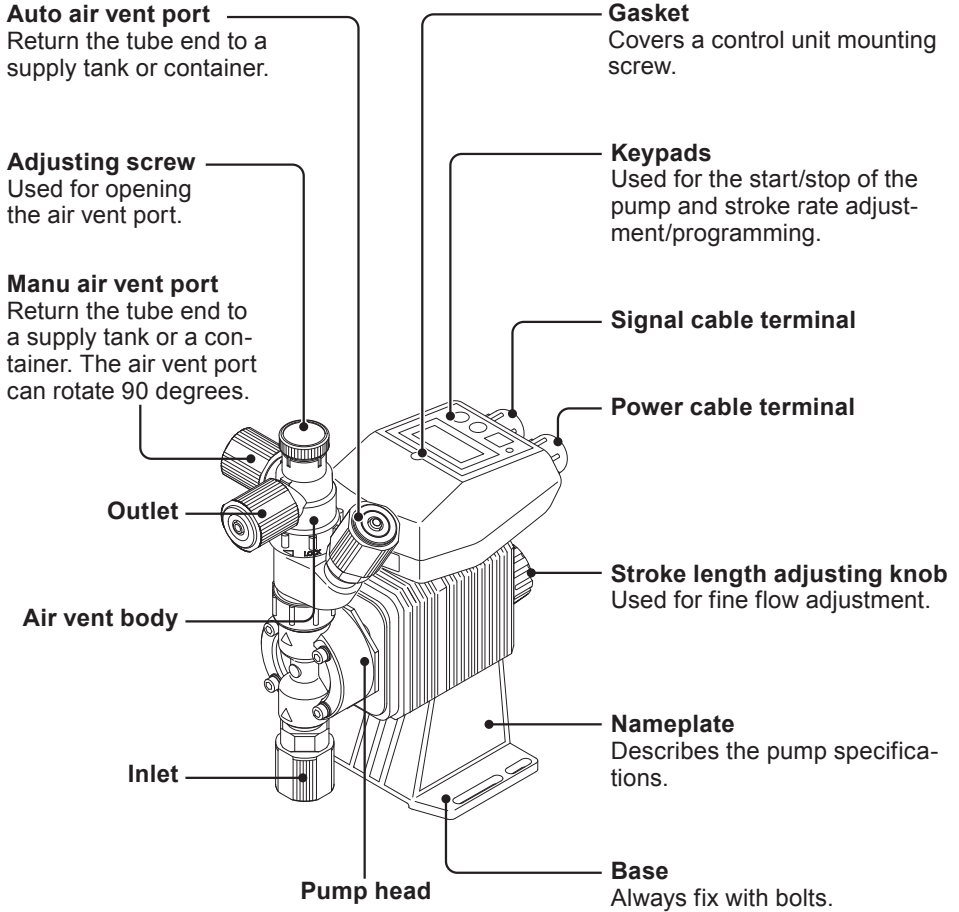

## Display

An operational status, a selected mode and a programmed value are shown here.

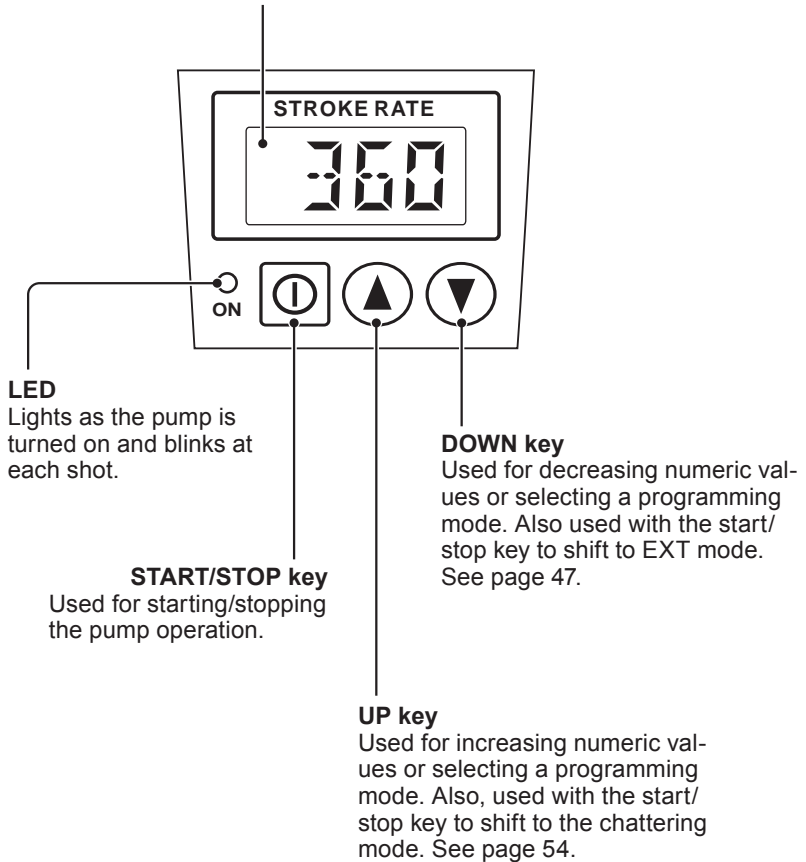

## LED

Lights as the pump is turned on and blinks at each shot.

## START/STOP key

Used for starting/stopping the pump operation.

## DOWN key

Used for decreasing numeric values or selecting a programming mode. Also used with the start/stop key to shift to EXT mode. See page 47.

## UP key

Used for increasing numeric values or selecting a programming mode. Also, used with the start/stop key to shift to the chattering mode. See page 54.

■ Basic displays & Pump states

	LED lights	LED blinks
	A wait state in MAN mode The screen shows the MAN speed (spm).	Operation in MAN mode. A current spm flashes. The screen shows MAN speed.
	A wait state in EXT mode (E-EX), waiting for the external signal.	Operation in EXT mode (E-EX) with the external signal.
	A wait state in EXT mode (E-SP), waiting for the external signal. The screen shows ".0".	Operation in EXT mode (E-SP), with the external signal. The screen shows MAN speed.
	STOP signal is entered to the pump to suspend its operation.	—
	STOP signal is entered to the pump while the pump is stopped and the mode is MAN.	—
	Anti-chattering values. T-5, T-10, and T50 represent the approximate time (msec) to read the external pulse signal.	—
	EXT mode with a preset divisor	—
	EXT mode with a preset multiplier	—
	A divisor selected for EXT mode. "/5" represents the pump makes one shot at every five(5) signals.	—
	A multiplier selected for EXT mode. "X5" represents the pump makes five(5) shots per signal.	—
	The pump behaviour with the STOP signal is selected.	—
	The number of external signals has exceeded the upper limit spm (MAN speed) in EXT mode. The pump does not run over the MAN speed.	—
	Keypad is locked. Any key operation is ineffective. See page 63 to release this state.	Keypad is locked. Any key operation is ineffective. See page 63 to release this state.

## Identification codes

The model codes of the pump/drive units and the control unit represent the following information.

### Pump/Drive units

EHN - B 11 VC \_ M R - NAE - \_  
 a      b   c   d   e   f   g      h      i

#### a. Series name

EHN: Multivoltage electromagnetic metering pump

#### b. Drive unit (average power consumption)

B: 20W              C: 24W

#### c. Diaphragm effective diameter

11: 10mm          16: 15mm          21: 20mm

#### d. Wet end materials

Code	Pump head	Valve	O ring	Valve seat	Gasket	Diaphragm
VC	PVC	Alumina ceramic	FKM	FKM	PTFE	PTFE + EPDM (dry end)
VH		HC276	EPDM	EPDM		

#### Auto air vent wet ends

Code	Guide A	Guide B	Valve	Separate pin	Valve seat	O ring
VC	PVC	PVC	Zirconia ceramic	Titanium	FKM	FKM
VC-S6				SUS316		
VC-HC				HC276		
VH			HC276	EPDM	EPDM	

#### Material code

PVC: Transparent polyvinyl chloride

EPDM: Ethylene-propylene rubber

FKM: Fluorine-contained rubber

PTFE: Polytetrafluoroethylene

HC276: HASTELLOY C276

**e. Tube size (I.D.xO.D.)**

No code:  $\varnothing 4 \times \varnothing 9 / \varnothing 4 \times \varnothing 6$

\*A numeric code represents a custom tube size.

**f. Fitting**

M: Multi-tube connection

**g. Control unit function**

R: Standard

**h. Degassing system**

NAE: Auto degassing type

**i. Separate pin**

No code: Titanium

HC: HASTELLOY C276

S6: SUS316

***Control unit***

---

EHNC - B R -       
           a      b c      d

**a. Model**

EHNC: Multivoltage control unit

**b. Drive unit**

B: 20W      C: 24W

**c. Control unit function**

R: Standard

**d. Special version**

No code: Standard

01-99: Customized model

# Installation

Installation of the pump, tubing, and wiring are described in this section.

## **!** Observe the following points when installing the pump.

- Risk of electrical shock. Be sure to turn off power to stop the pump and related devices before service is performed.
- If you notice any abnormal or dangerous conditions, suspend operation immediately and inspect/solve problems.
- Do not place explosive or flammable material near the pump.
- Do not use a damaged pump. Use of a damaged pump could lead to an electric shock or death.

## Pump mounting

Select the optimal installation location and mount the pump.

### Necessary tools

- Four M5 bolts (pump mounting)
- An adjustable wrench or spanner

### 1 Select a suitable place.

Select a level location, free from vibration, that won't hold liquid. See page 10 for detail. Flooded suction installation is strongly recommended when handling liquids that generate gas bubbles (sodium hypochlorite or hydrazine solution).

### 2 Anchor the pump with the M5 bolts.

Be sure to fix the pump at four points.

#### NOTE

If the pump is not installed level, output may be affected.

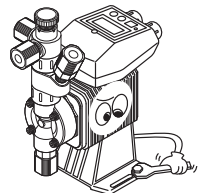

# Plumbing

Connect tubes to the pump and install a check valve.

## Before operation

- Cut the tube ends flat.

Tube end (Side view)



## Necessary tools

- An adjustable wrench or a spanner

## Tube connection

- Pass a tube into the fitting nut and stopper and then slide it down to the adapter as far as it will go.
- Put the tube end (adapter) in the fitting. Then hand tighten the fitting nut.
- Retighten the fitting nut by turning it further 180 degrees with an adjustable wrench or spanner (crush tube end).

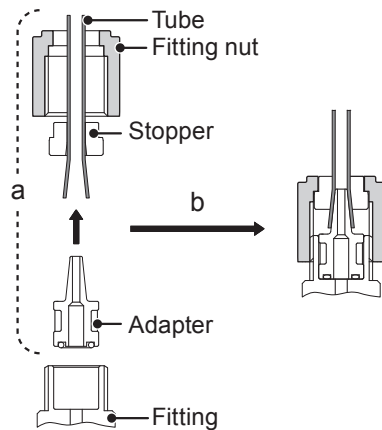

\*Do not use excessive force to the plastic fitting nut.

\*In your try to remove the connection, the adapter may be stuck in the crushed tube and the stopper. Try not to damage the taper of the adapter that is crushing the tube against the stopper. If it has been damaged, contact us for the new adapter/stopper.

\*Do not reuse the same tube end for the crush sealing. Cut it off for ensuring the new seal is established.

\*A 3m PVC braided tube is included with shipment. If it's not long enough, purchase a general PVC braided tube with a proper connection size.

**1 Connect tubes into the inlet and outlet.**

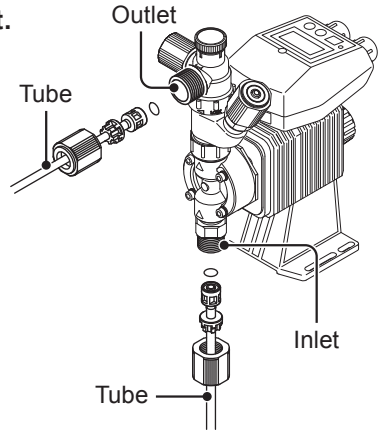

**2 Connect a tube to establish the MANU air vent line.**

Route back the other tube end to a supply tank or a container.

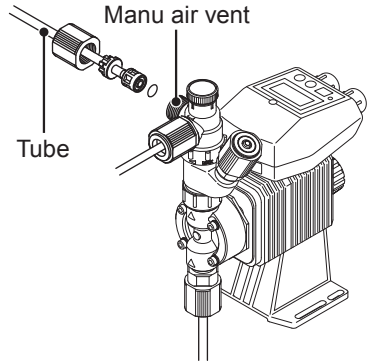

**3 Connect a tube to establish the AUTO air vent line.**

Route back the other tube end to a supply tank or a container.

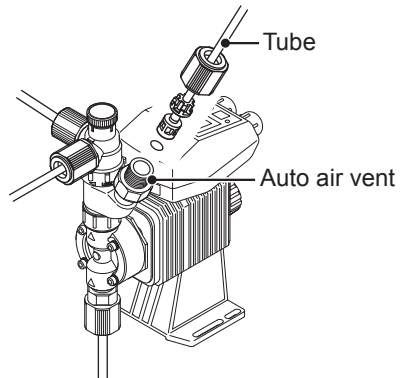



## Check valve mounting

Install an attached/optional check valve to the pump for the prevention of a back flow, siphon and overfeeding. In the following cases be sure to install the check valve to the discharge line end.

- A suction side liquid level is higher than a discharge side or an injection point at atmospheric pressure.

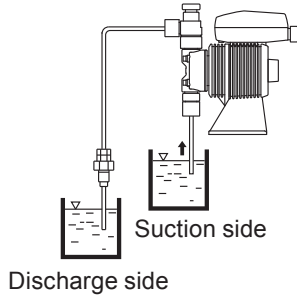

- A discharge side liquid level is higher than a suction side but the distance is 5m or below.

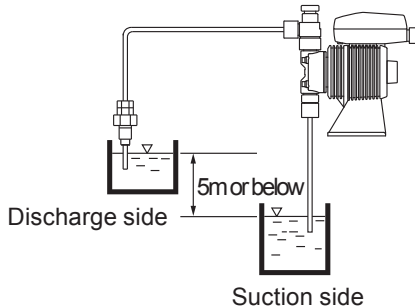

- A suction line pressure is higher than a discharge line pressure.

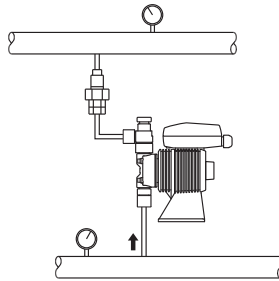

- A discharge pressure (including pipe resistance and discharge head) is below 0.13MPa.

## 1

**Mount a check valve at the discharge tube end.**

\*The discharge tube length must be 1m or longer.

\*The CAN check valve has the R1/2 and R3/8 thread connections as well as an O.D.9mm tube connection. Cut off an unused part and adjust the connection length as necessary.

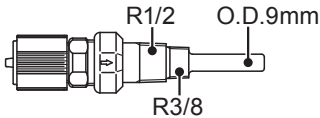
**CAN check valve****NOTE**

- Periodically clean or replace a check valve with new one for the prevention of crystal clogging, especially when using sodium hypochlorite.
- The discharge line length (between the pump outlet and the CAN check valve) must be longer than 1m.
- In the nature of the pump, the lower discharge pressure, the higher discharge capacity (and vice versa). If you want to observe the max discharge capacity at any low level of system (discharge) pressure, use the check/back pressure valve to give the additional pressure of  $0.17\text{MPa} \pm 0.04$  to the discharge line or reduce the pump speed/stroke length.
- Do not use excessive force or large wrenches when the CAN check valve is connected to a threaded pipe (discharge line) via its R1/2 or R3/8 female thread connection. The connection point of the plastic check valve may break. The rated tightening torque of  $10\text{N}\cdot\text{m}$  must be observed.

## Tubing layout

### Flooded suction application

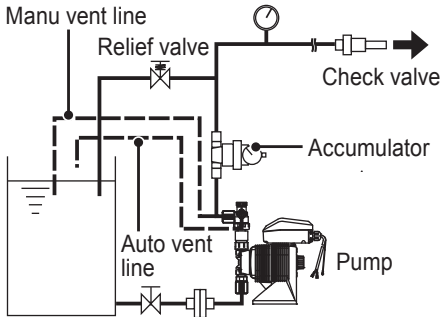

### Suction lift application

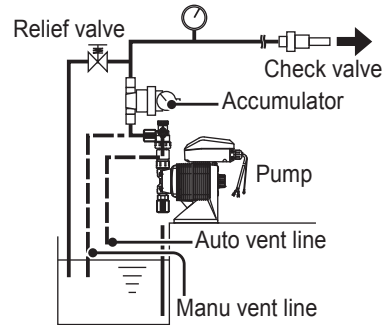

- \*Install a branched pipe and a relief valve on the discharge line for the prevention of excessive pressure that might be caused by a clogged injection point.
- \*Flooded suction installation is strongly recommended when handling liquids that generate gas bubbles (sodium hypochlorite or hydrazine solution).
- \*When flooded suction installation is established, keep the suction line length shorter than 1m for ensuring the auto degassing system works properly. Any longer length may contain too much gas inside which exceeds the degassing capability of the pump, however, use of an optional Iwaki DG degassing joint to the pump inlet can help enhance the degassing capability.
- \*When the pump and system are restarted after a long interval, be sure to expel gas from the pump and the suction line manually through the degassing step on page 35.
- \*Liquid pressure is released from the auto air vent line in the form of solution spray when it has exceeded the opening pressure of the auto air vent valve. The solution spray also occurs in operation under siphon effect. Be sure to route back the end of the auto air vent line to a supply tank or a container.
- \*The auto air vent line to a supply tank or a container must be established in the possible shortest distance without any arched line.
- \*Keep the auto vent line open ended to atmosphere. Do not immerse the tube end in solution in a supply tank.

## Wiring

*Wiring for a power voltage, earthing and an external signal.*

### **!** Observe the following points during wiring work.

- Electrical work should be performed by a qualified electrician. Always observe local electric codes.
- Observe the rated voltage range, or the electrical circuit in the control unit may fail.
- Do not perform wiring work while electric power is ON. Otherwise, an electrical shock or a short circuit may result. Be sure to turn off the power before wiring work.
- Be careful for the power not to be turned on during work.

### Necessary tools

- An adjustable wrench or spanner
- A Phillips screw driver
- A precision screw driver

## ***Power voltage/Earthing***

Check that the main power is turned off.

### **1** Connect power cable via crimp contacts.

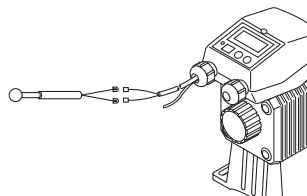

### **2** Earth the pump. Be sure to earth the pump.

## NOTE

- Do not share a power source with a high power device which may generate surge voltage. Otherwise an electronic circuit may fail. The noise caused by an inverter also affects the circuit.
- Energize the pump with a power voltage via a mechanical relay or switch. Do not fluctuate the voltage, or CPU may malfunction. See page 30 for the precautions for ON-OFF control by a mechanical relay.

### Apply power sharply

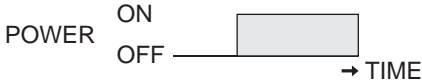

### Do not apply gradually



## Surge voltage

The electronic circuit in the control unit may fail due to surge voltage. Do not place the pump close to a high power device of 200V or more which may generate large surge voltage. Otherwise, take any of the following measures.

- Install a surge absorption element (ex. a varister with capacity of 2000A or more) via power cable.

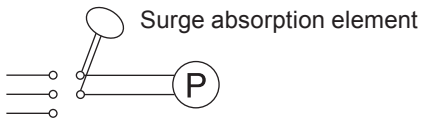

### Recommended varisters

Panasonic ERZV14D431

KOA NVD14UCD430

See manufacturer's catalogues for detail.

- Install a noise cut transformer via power cable.

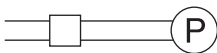

Noise cut transformer

### **Precautions for ON-OFF control by a mechanical relay**

This pump is equipped with a CPU. To ensure the CPU to work properly, always start/stop the pump by the STOP signal for ON-OFF control. Try not to turn on and off the main power. Otherwise, observe the following points:

- Ensure the minimum OFF time of 10 minutes.
- The contact capacity of a mechanical relay should be 5A or more. Or a contact point may break.
- If the contact capacity of a mechanical relay is 5A, the maximum allowable number of times the power is turned ON/OFF is limited to 150,000. Use the contact capacity of 10A or more when the actual number of times is over 150,000 or when sharing a power source with a large capacity equipment which may cause a surge voltage and damage a contact point.
- Use a solid state relay (SSR) as necessary (such as the OMRON G3F). See manufacturer's catalogues for detail.

## ***Signal wire connection***

---

### **Points to be checked**

- Check that the main power is turned off.  
The pump is still charged right after turning off power. Wait for one minute before wiring is performed.

### **Applicable cables**

Triplex cable: VCTF-3 1.25mm<sup>2</sup>

Duplex cable: UL, CSA SJT 18AWG/2

\*The outer diameter of these signal cables must be 7.8mm. A cable with the larger OD than 7.8mm can not be fitted to the controller. A smaller OD cable may impair water-/dust-tightness of the controller.

## NOTE

- Do not lay on these signal cables in parallel with a power cable. Otherwise the electromagnetic induction noise is generated and malfunction or failure may result.
- The following products are the recommended SSRs (Solid State Relays) for signal input. Any other SSRs may cause malfunction. See manufacturer's information for details on these SSRs.
  - OMRON G3FD-102S or G3FD-102SN
  - OMRON G3TA-IDZR02S or G3TA-IDZR02SM
- When using a mechanical relay for signal input, its minimum application load should be 5mA or below.

\*Use either a no-voltage contact or an open collector for the external signal.

\*Set pulse duration in 10-100ms and the number of pulses at or below 360 pulses per minute.

### 1 Demount the control unit.

- a. Remove the rubber cap, fixing screw and gasket from the top of the unit.
- b. Loosen the two tapping screws (A) located above the stroke length adjusting knob and detach the control unit.

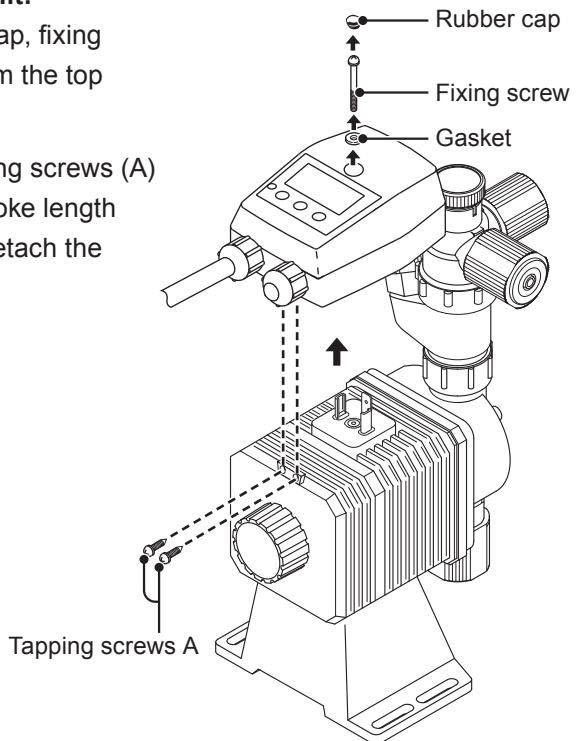

## 2 Loosen four(4) tapping screws (B) and open the controller cover.

\*The controller cover can not be totally removed. The LCD display PCB in the controller cover is cabled to the main PCBA in the controller case.

\*The controller cover and the case are sealed by a case gasket. Make sure the gasket is in place when replacing the cover.

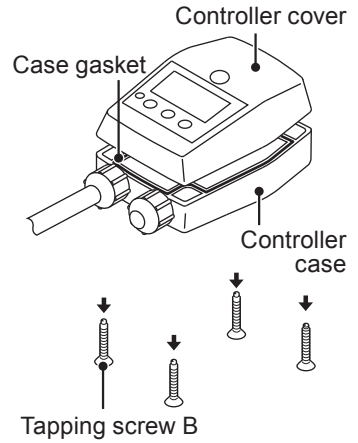

## 3 Remove the cable nut, the protective cap, and the cable gasket.

\*The cap is not used after a cable is connected to the terminal.

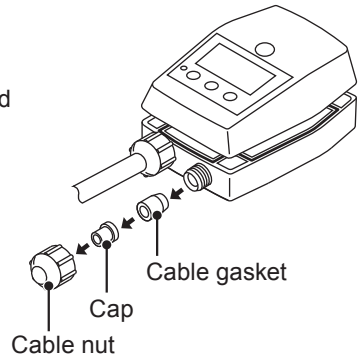

## 4 Pass the O.D. 7.8mm external signal cable into the cable nut and the cable gasket.

\*The cable gasket has the mounting directions as shown right.

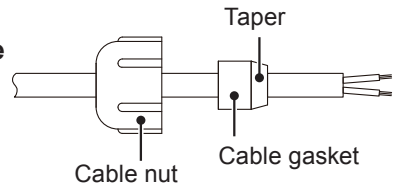



## 5 Connect the external signal cable.

- Detach the plug from the socket.
- Use a precision screwdriver to connect signal wires to the plug.
- Replace the plug to the socket.
- Take up the slack of the cable.
- Hand-tighten the cable nut.

\*The cable is held to the case when cable nut is tightened over the cable gasket.

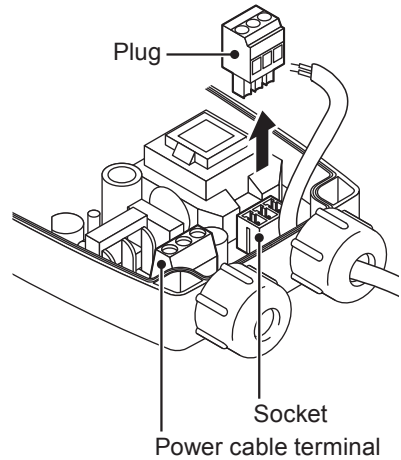

### Wiring diagram

When a no-voltage contact is used

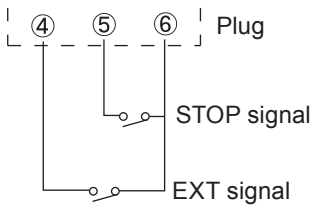

When an open collector signal is used

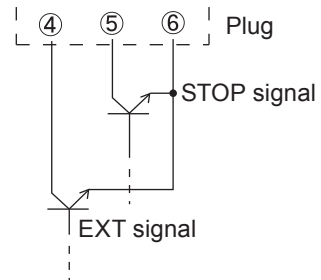

## 6 Reassembly and remount the control unit.

### Tightening torque

Fixing screw (control unit)	0.39 N•m
Tapping screw A (controller case)	0.39 N•m
Tapping screw B (controller cover)	0.8 N•m

### NOTE

Always check that gaskets (a rubber cap, fixing screw gasket and a case gasket) are fitted in place for ensuring water-/dust-tightness to the control unit.

# Operation

*This section describes pump operation and programming. Run the pump after pipework and wiring is completed.*

## Before operation

*First check tubing and wiring are correct. And then perform degassing and flow rate adjustment before starting operation.*

### ***Points to be checked***

---

*Before operation, check if:*

- Liquid level in a supply tank is enough.
- Tubing is securely connected and is free from leakage and clogging.
- Discharge/suction valves are opened.
- A power voltage is in the allowable range.
- Electrical wiring is correct and is free from the risk of short circuit and electrical leakage.

### ***Retightening of pump head fixing bolts***

---

#### **Important**

The pump head fixing bolts may loosen when plastic parts creep due to temperature change in storage or in transit. This can lead to leakage. Be sure to retighten the bolts evenly to 2.16N•m in diagonal order before starting operation.

\*Tighten fixing bolts once every three months.

## ■ Use of hexagon wrench instead of a torque wrench

Fasten the fixing bolts as tight as can be by the hand with the straight long part of a hexagon wrench (a) and further turn the bolts clockwise 90 degrees with the short part (b).

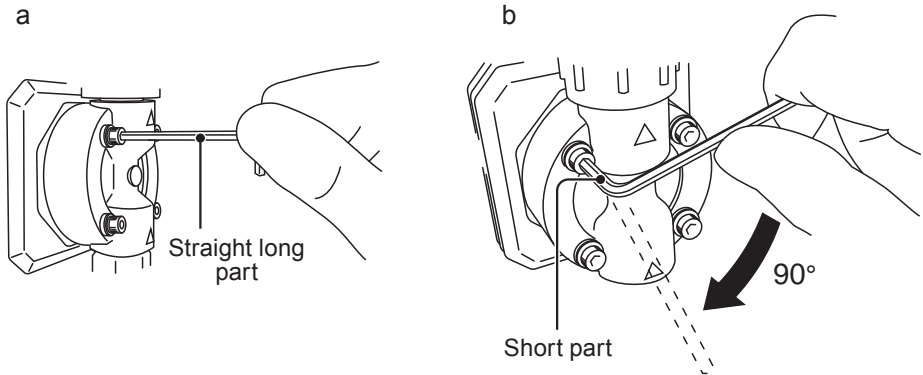

## ***Degassing***

*The gas in the pump and tubing is the obstacle to liquid delivery and needs to be expelled before the pump is started. Especially:*

- When the pump starts to run for the first time
- When a flow rate is too low
- After liquid is replaced in a supply tank
- After a long period of stoppage
- After maintenance and inspection are performed

### NOTE

- Both gas and chemical come out together through an air bleed tube. Make sure the end of the tube is located in a supply tank or a container.
- Some chemicals may damage skin and dry end parts. Wash/wipe chemicals off immediately if they got wet.
- The auto air vent may be unusable when air lock exists in the pump head. Use the adjusting screw to manually lead the gas trapped to the manu vent line.

**Points to be checked**

- An air bleed tube is connected to the pump.

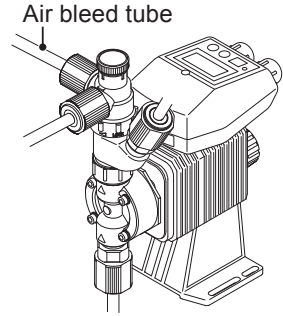

1

**Turn on power.**

The ON LED and the display are turned ON.

\*The pump waits in the MAN mode when turned on with the factory default setting.

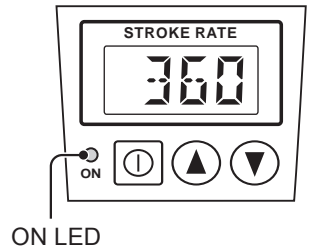

2

**Set a stroke rate to 360spm.**

See page 39 "Stroke rate adjustment" for detail.

3

**Rotate the adjusting screw two revolutions anticlockwise to open the manu vent port.**

\*Do not rotate it three revolutions. The adjusting screw may come off with solution spray.

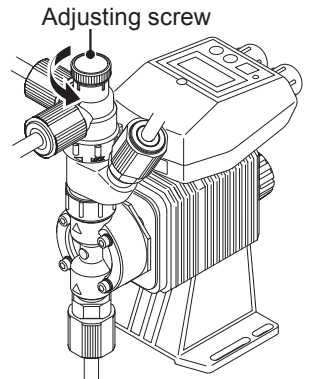

- 4 **Push the start/stop key and run the pump for more than ten minutes.**

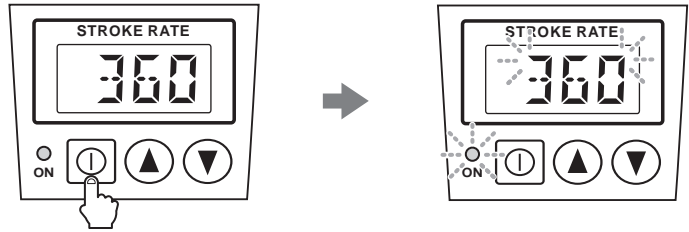

- 5 **Push the start/stop key and stop the pump.**

- 6 **Rotate the adjusting screw clockwise to close the vent port.**

- 7 **Check liquid is delivered to the discharge line.**  
Degassing must be repeated until liquid is outputted from the pump outlet.

- 8 **Check connections for leakage.**  
Degassing has now been completed.

## ***Flow rate adjustment***

---

*The flow rate can be changed by a stroke rate and a stroke length adjustment.*

The stroke rate represents the pump speed in spm (stroke per minute). The stroke rate adjustment is the main way to adjust the flow rate from the pump.

The stroke length represents the moving distance of the plunger. The widest moving distance is defined as 100% stroke length. The stroke length adjustment is used for determining the optimal flow volume per shot (fine adjustment of the pump flow).

First adjust a flow rate by stroke rate adjustment. Use stroke length adjustment for the range where stroke rate adjustment can not reach. Note the optimal stroke length change with operating conditions and liquid characteristics.

### **1 Change the stroke rate with the stroke length 100% to the specified level.**

See "■ Stroke rate adjustment" on page 39 and "■ Stroke length adjustment" on page 41 for detail.

### **2 Measure the flow rate.**

### **3 If the flow rate is lower/higher than the specified level, increase/decrease the stroke rate and measure the pump flow again.**

### **4 Change a stroke length for fine adjustment.**

### **5 Measure the pump flow again to see the specified level is obtained.**

## Flow rate, stroke rate and stroke length

### B type

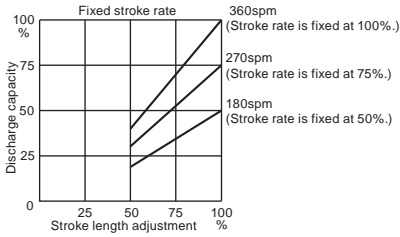

### C type

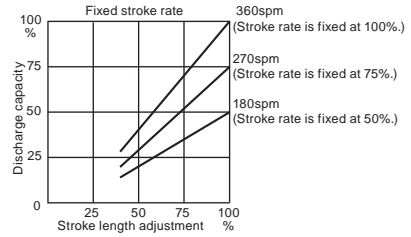

## Precautions of flow rate adjustment

- **When back pressure is high**

Set stroke length to 100% and adjust the pump flow by changing the stroke rate.

- **When each dose greatly affects a chemical reaction in neutralization or titration application**

Shorten the stroke length to reduce the flow rate per shot. And then adjust the pump flow by changing the stroke rate.

- **When handling liquids that generate gas bubbles (sodium hypochlorite or hydrazine solution).**

Set the stroke length to 100% and adjust the pump flow by changing the stroke rate. Note air lock may occur when the stroke length is set too short.

### ■ Stroke rate adjustment

The stroke rate can be set by keypad operation from 1 to 360spm. The relation between the flow rate\* and the stroke rate is shown as below.

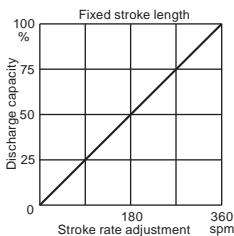

\*The flow rate on the nameplate falls on 100% discharge capacity and stroke length.

## 1 Turn on power and call up manual mode.

Enter manual mode to show a stroke rate (spm) on the screen.

- Push the start/stop key when the pump is in the EXT mode.
- When "STOP" or "-STOP" appears on the screen, see page 60 to cancel the condition.

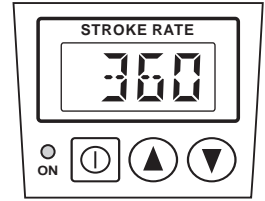

## 2 Use the UP or DOWN key to adjust a stroke rate.

- The stroke rate increases/decreases by 1spm every time the key is pushed.
- Press and hold either key for three seconds for quick change. Quick change stops at 1 or 360spm and then skips to 360 or 1spm when the key is released once and pushed again.

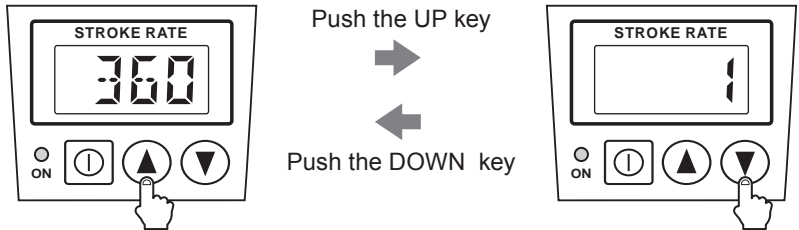

## 3 Push the start/stop key.

The ON LED and the stroke rate blink at each shot during operation.

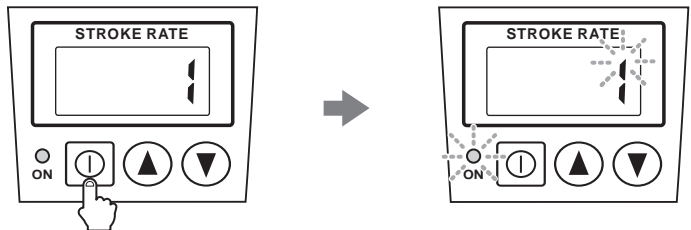



## ■ Stroke length adjustment

The stroke length can be adjusted when the moving distance of the plunger is changed by the stroke length adjusting knob.

The stroke length adjustment range is 50-100% for the B type, 40-100% for the C type. The relation between the flow rate\* and the stroke length is shown as below.

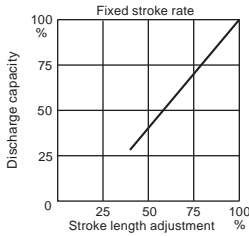

\*The flow rate on the nameplate falls on 100% discharge capacity and stroke length.

### NOTE

Do not rotate the stroke length adjusting knob when the pump is not running.

1

### Turn on power and push the start/stop key to run the pump.

The ON LED and the stroke rate blink during operation.

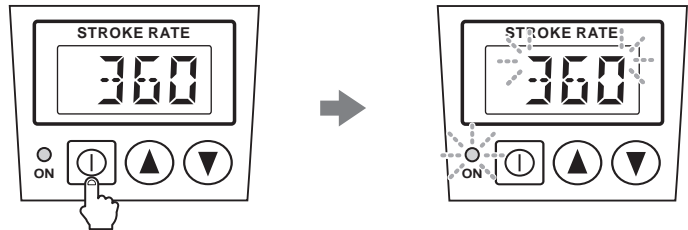

- 2 **Rotate the stroke length knob to determine liquid volume per shot.**

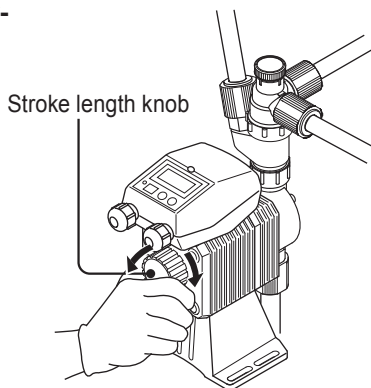

### ***Before a long period of stoppage (one month or more)***

#### **Clean wet ends and the inside of tubing.**

- Run the pump with clean water for about 30 minutes to rinse chemicals off from the pump head and piping.

#### **Before unplugging the pump**

- Always stop the pump by key operation and wait for three seconds before unplugging the pump. Otherwise, the last key operation may not be put in memory. In this case the pump unintentionally starts to run as powered on, discharging liquid.

#### **When the pump does not transfer liquid at resuming operation.**

- Clean the valve sets and remove foreign matters.
- If gas is in the pump head, expel gas and readjust a flow rate. See "Degassing" on page 35 and "Flow rate adjustment" on page 38 for detail.

## Operation programming

Operation at each mode is individually set and controlled by keypad operation. Select a proper mode to make optimal operation.

### Default setting and Setting range

Parameters	Default setting	Setting range	Step
Stroke rate (MAN speed)* <sup>1</sup>	360	1-360	1* <sup>2</sup>
Multiply/Divide selection	/NNN	/NNN, XNNN	-
Divisor	1	1-999	1* <sup>2</sup>
Multiplier	1	1-999	1* <sup>2</sup>
EXT mode display selection	E-EX	E-EX/E-SP	-
Anti-chattering time* <sup>3</sup>	T-5	T-5/T-10/T-50	-
STOP function	M-OF	M-ON/M-OF	-

\*<sup>1</sup> Used as the upper limit spm in EXT mode.

\*<sup>2</sup> The stroke rate increases/decreases by 1spm every time the up or down key is pushed. Press and hold either key 3 seconds for quick change.

\*<sup>3</sup> It becomes more immune to contact bounce/electrical noise with the longer anti-chattering time but then can ignore any pulse length shorter than the threshold. The "T-5", "T-10", and "T-50" thresholds individually stand for 5, 10, and 50 msec pulse length. Select the minimum allowable threshold to any actual pulse inputted (the actual pulse length must be longer than the threshold).

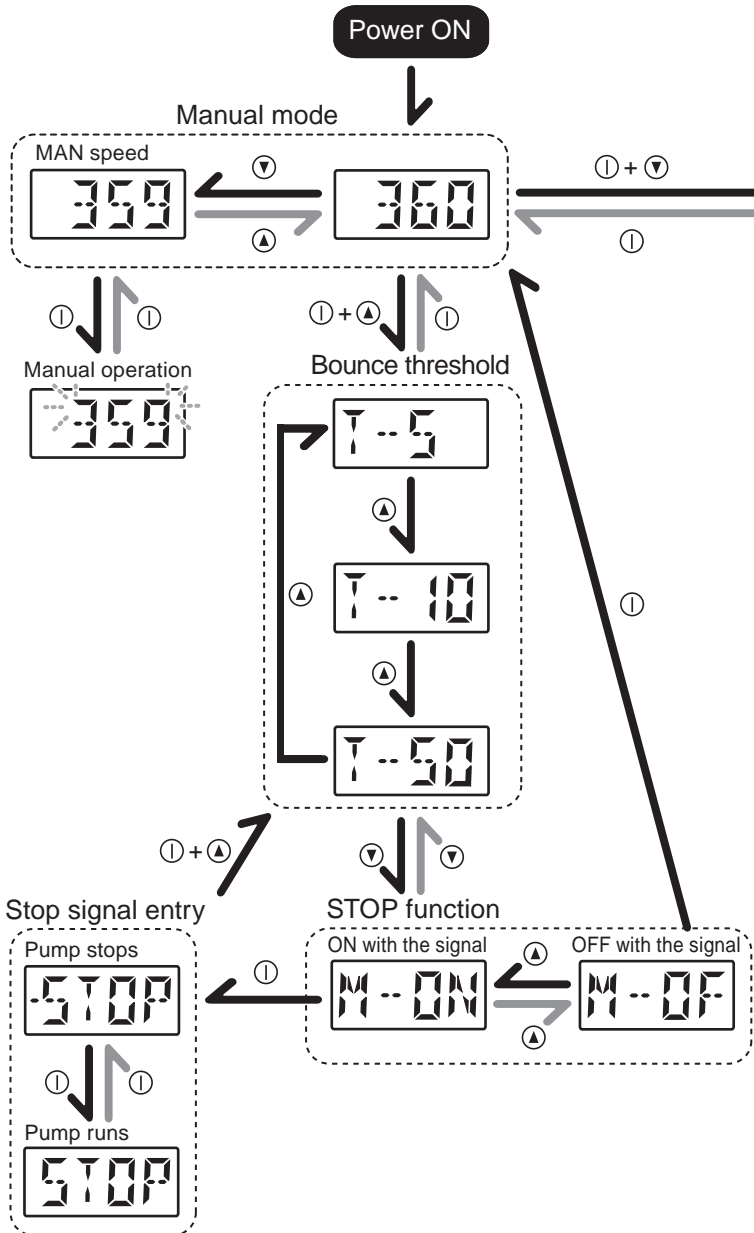

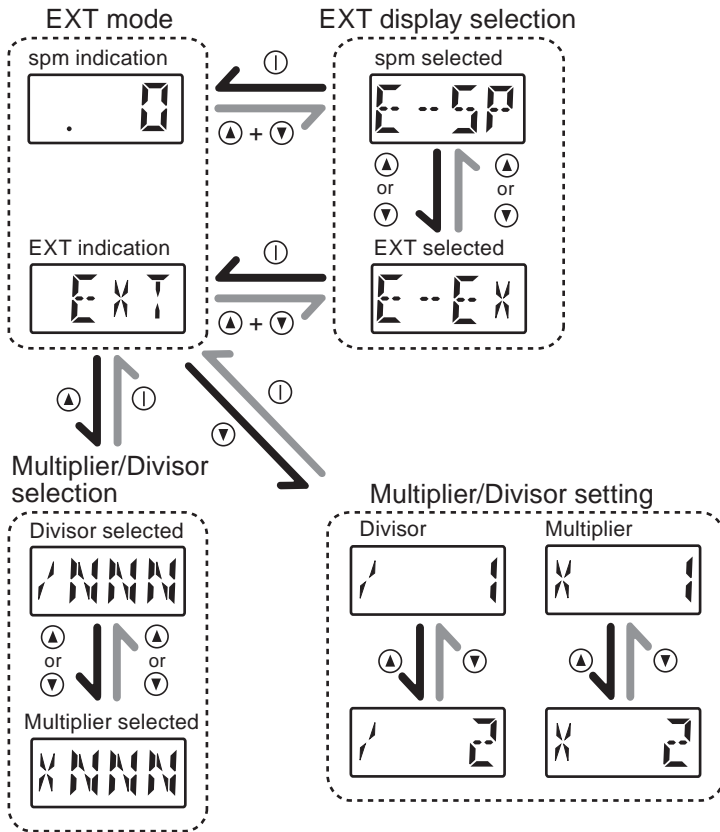

### Keypad lock

Any key operation is ineffective once keypads are locked.

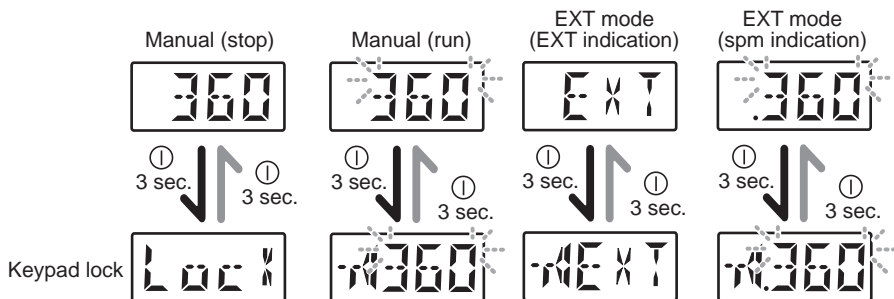

1

## Turn on power.

The ON LED and the display are turned ON.

\*The pump waits in the MAN mode when turning on power with a default setting or calls up a previous mode at the last shutoff.

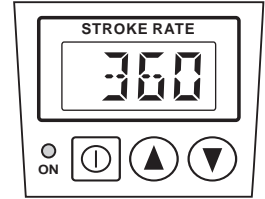

2

## Enter manual mode.

Move to the next step when the pump is already in the manual mode.

### When "EXT" or ".0"-".360" is on the screen:

Push the start/stop key once to enter the wait state in manual mode.

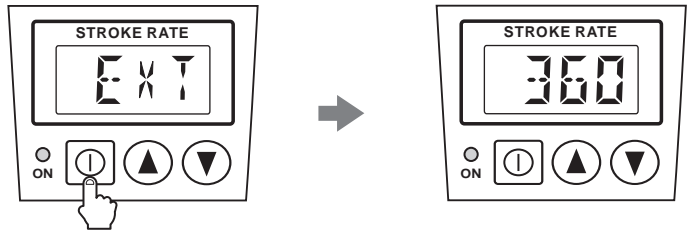

### When "STOP" or "-STOP" is on the screen:

Cancel the STOP function. See page 60.

### 3 Use the UP or DOWN key to adjust a stroke rate.

- The stroke rate increases/decreases by 1spm every time the key is pushed.
- Press and hold either key for three seconds for quick change. Quick change stops at 1 or 360spm and then skips to 360 or 1spm when the key is released once and pushed again.

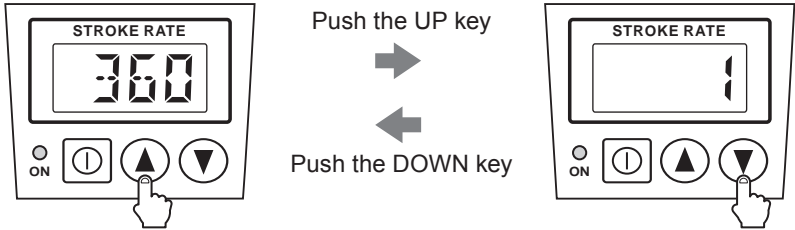

### 4 Push the start/stop key.

The ON LED and the stroke rate blink at each shot during operation.

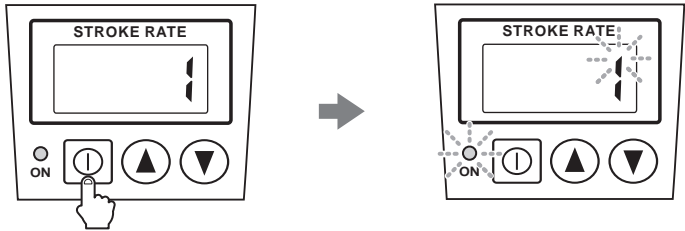

## EXT operation

The pump operation is controlled by the external (pulse) signal.

### ■ EXT mode

Set the upper limit spm (MAN speed) and enter EXT mode. Note that the pump starts to run in sync with the external signal as entering EXT mode.

## NOTE

- The pump does not run over the manual stroke rate (MAN speed). If the MAN speed is set to 200spm, for example, the pump does not run over the speed with any multiplier or divisor settings.
- The MAN speed skips from 360spm (/1spm) to 1spm (/360spm) when the up (/down) key is pushed once.

### 1 Turn on power and call up manual mode.

Enter manual mode to show a stroke rate (spm) on the screen.

- Push the start/stop key when the pump is in the EXT mode.
- When "STOP" or "-STOP" appears on the screen, see page 60 to cancel the condition.

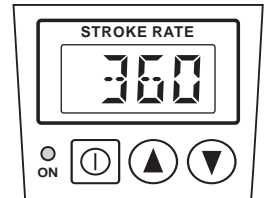

### 2 Use the UP or DOWN key to set the MAN speed.

Push the start/stop key and stop the pump when it is running.

- The stroke rate increases/decreases by 1spm every time the key is pushed.
- Press and hold either key for three seconds for quick change. Quick change stops at 1 or 360spm and then skips to 360 or 1spm when the key is released once and pushed again.

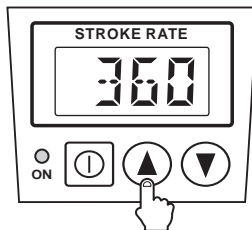

Push the UP key



Push the DOWN key

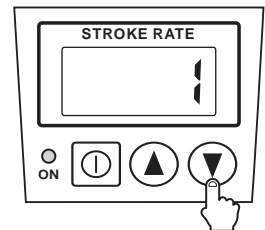



### 3 Push the DOWN key while pressing the start/stop key to enter EXT mode.

Note that the pump starts to run in sync with the external signal as entering EXT mode.

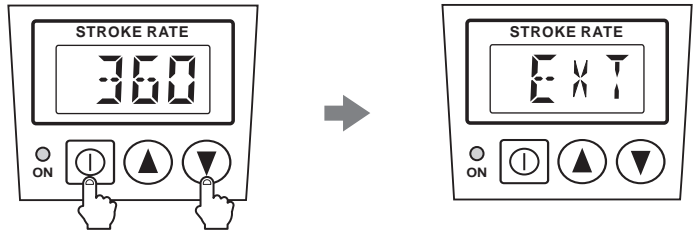

#### ■ EXT mode setting

The following features can be set for the EXT operation.

##### • Multiplier setting

The number of shots per signal is entered.

##### • Divisor setting

The number of signals per shot is entered.

##### • Anti-chattering setting

The minimum allowable pulse length is set to prevent the adverse affect by chattering (contact bounce) and electrical noise.

##### • Display selection

Either "EXT" or "spm" indication is selected for EXT mode.

#### NOTE

Any EXT mode setting will not be entered unless the start/stop key is pushed for confirmation. Also, note if the pump is unplugged before the start/stop key is pushed, your setting will be no longer effective.

#### Glossary

##### Chattering

The rapid, repetitive noises made from contact bounce of the mechanical relay or switch. Chattering can cause malfunction to electric devices or parts.

## Multiplier setting

The pump increases/decreases a stroke rate by the external signal and the multiplier. Set a multiplier (1-999 shots) per pulse in advance of operation.

### NOTE

Do not enter the external signal before this setting is completed.

#### 1 Enter EXT mode.

- Push the DOWN key while pressing the start/stop key to move from manual mode to EXT mode.
- Push the start/stop key and stop the pump before setting is performed.

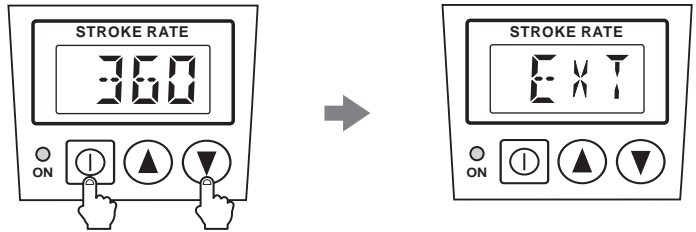

#### 2 Push the UP key and enter the multiplier/divisor selection.

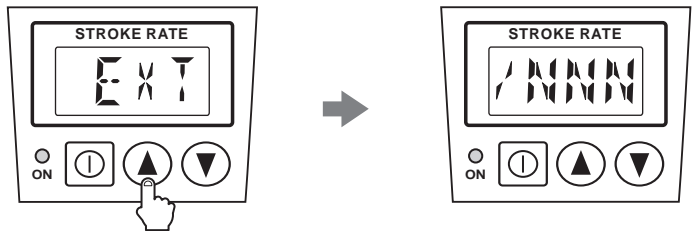

#### 3 Select "X NNN" (multiplier).

"X NNN" (multiplier) or "/ NNN" (divisor) can be selected by the UP and DOWN keys.

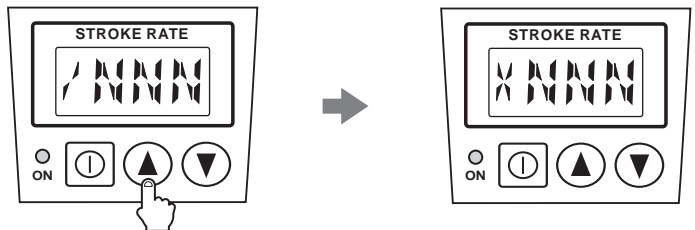

4 Push the start/stop key to return to EXT mode.

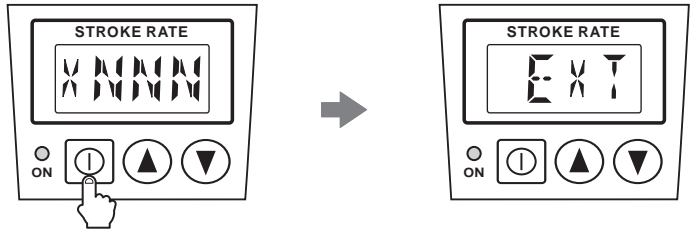

5 Push the DOWN key and call up the multiplier setting screen.

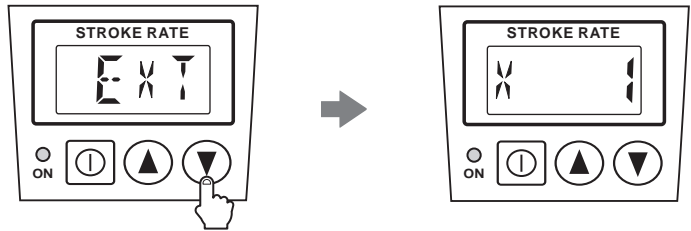

6 Use the UP or DOWN key to set a multiplier.

- A multiplier increases/decreases as the UP or DOWN key is pushed.
- Press and hold either key for three seconds for quick change. Quick change stops at 1 or 360spm and then skips to 360 or 1spm when the key is released once and pushed again.

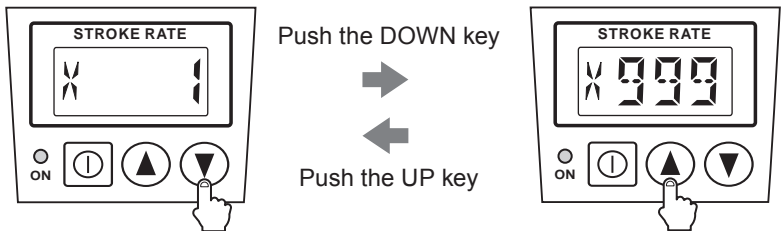

## 7 Push the start/stop key to return to EXT mode.

The pump runs according to the multiplier setting.

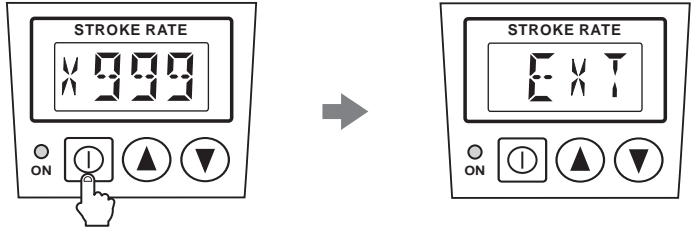

## Divisor setting

The pump increases/decreases a stroke rate by the external signal and the divisor. Set a divisor (1-999 pulse rates) per shot in advance of operation.

### NOTE

- If a divisor is set to 1, the pump speed equals to the external pulse rate (1:1 operation). This operation, however, may be upset when the pulse rate has exceeded the MAN speed and when the extra signals are cancelled. Although this is not malfunction, use of the multiplier is recommended to ensure correct 1:1 operation.
- Do not enter the external signal before this setting is completed.

## 1 Enter EXT mode.

- Push the DOWN key while pressing the start/stop key to move from manual mode to EXT mode.
- Push the start/stop key and stop the pump before setting is performed.

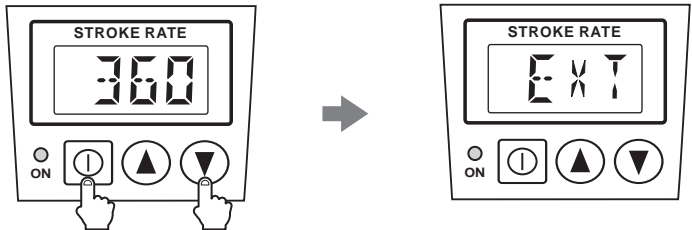

- 2 Push the UP key and enter the multiplier/divisor selection.

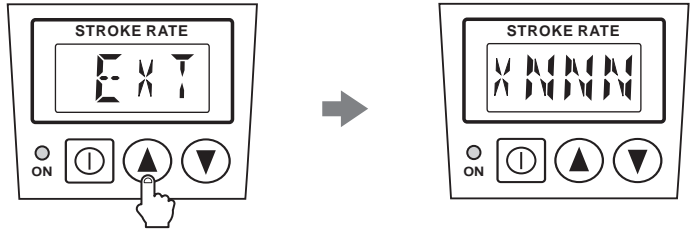

- 3 Select "/ NNN"(divisor).

"X NNN" (multiplier) or "/ NNN" (divisor) can be selected by the UP and DOWN keys.

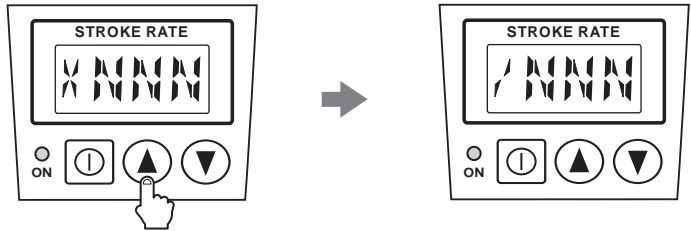

- 4 Push the start/stop key to return to EXT mode.

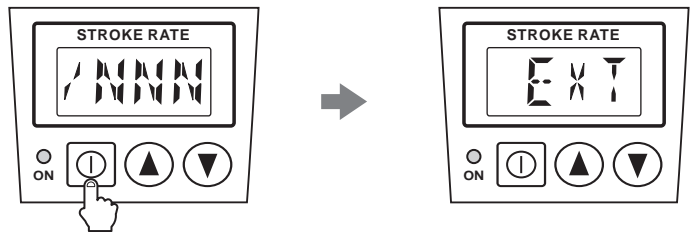

- 5 Push the DOWN key and call up the multiplier setting screen.

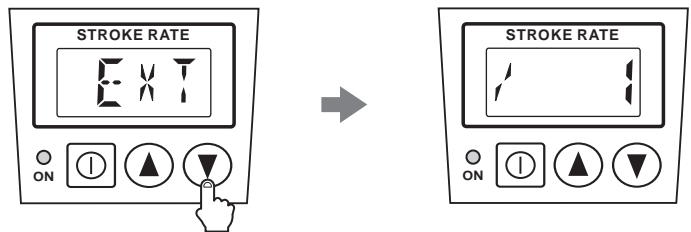

## 6 Use the UP or DOWN key to set a divisor.

- A divisor increases/decreases as the UP or DOWN key is pushed.
- Press and hold either key for three seconds for quick change. Quick change stops at 1 or 360spm and then skips to 360 or 1spm when the key is released once and pushed again.

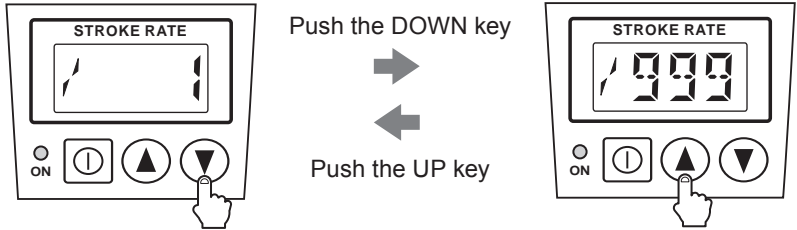

## 7 Push the start/stop key to return to EXT mode.

The pump runs according to the divisor setting.

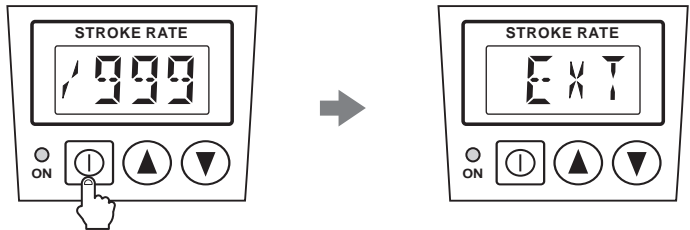

### Anti-chattering setting

The minimum allowable pulse length should be set to prevent the adverse effect of chattering (contact bounce) and electrical noise. The factory default setting is "T-5 (5msec)". Select the "T-10 (10msec)" or "T-50 (50msec)" choice accordingly if a longer pulse length than the default is inputted.

#### NOTE

When this product is used with the EUC-70P controller, select "T-5" (default setting).

The pump may not run with "T-10" or "T-50" bounce threshold.

## 1 Enter manual mode.

Push the start/stop key to return to manual mode if the pump is in EXT mode.

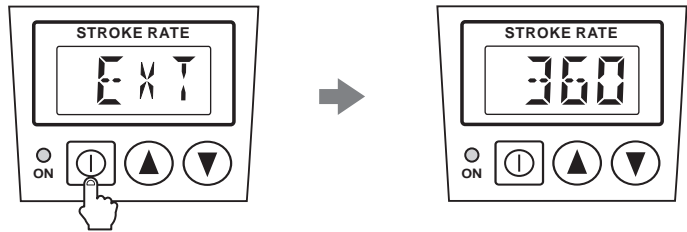

## 2 Push the UP key while pressing the start/stop key to call up the anti-chattering setting mode.

"T-5" (default setting), "T-10" or "T-50" appears on the screen.

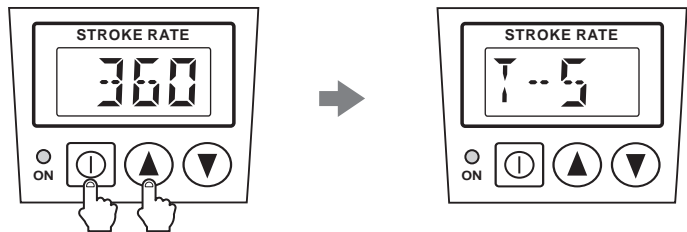

## 3 Push the UP key and select a pulse length threshold.

The UP key to change between the "T-5", "T-10" and "T-50" thresholds.

\*It becomes more immune to contact bounce/electrical noise with the longer anti-chattering time but then can ignore any pulse length shorter than the threshold. The "T-5", "T-10", and "T-50" thresholds individually stand for 5, 10, and 50 msec pulse length. Select the minimum allowable threshold to any actual pulse inputted (the actual pulse length must be longer than the threshold).

\*When this product is used with the EUC-70P controller, select "T-5" (default setting). The pump may not run with "T-10" or "T-50".

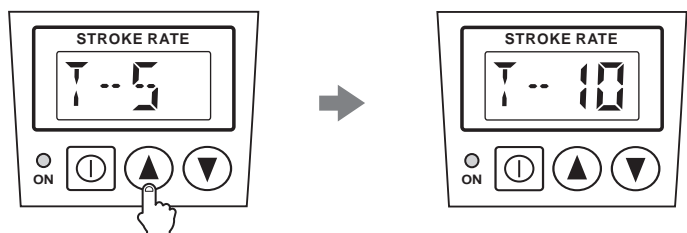

#### 4 Push the start/stop key to return to manual mode.

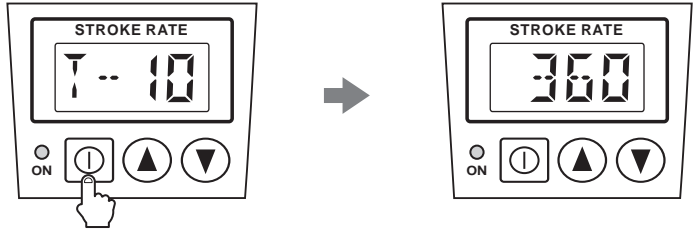

### Display selection

Either "EXT" or "spm" indication is selected for EXT mode.

The pump shows "EXT" on its screen when "E-EX" is selected, or a current pump speed when "E-SP" selected

#### NOTE

- With "E-SP" selected, the screen shows the calculation of a current pump speed (based on the multiplier/divisor and the number of external signals being inputted.).
- Do not enter the external signal before this setting is completed.

#### 1 Enter EXT mode.

- Push the DOWN key while pressing the start/stop key to move from manual mode to EXT mode.
- Push the start/stop key and stop the pump before setting is performed.

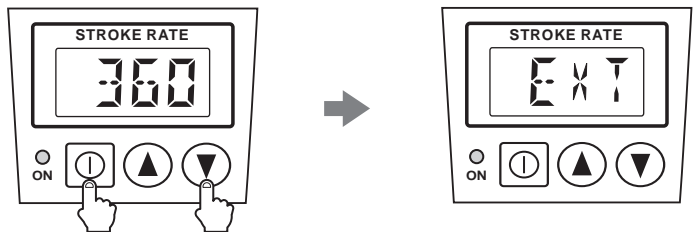



- 2 Push the DOWN key while pressing the UP key to call up the display selection mode.

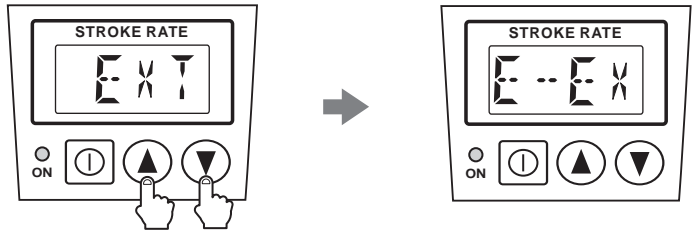

- 3 Push the UP or DOWN key to select "E-EX" (EXT indication) or "E-SP" (spm indication).

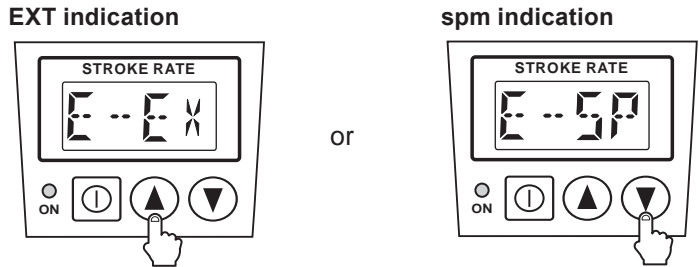

- 4 Push the start/stop key to return to EXT mode.

When spm indication is selected

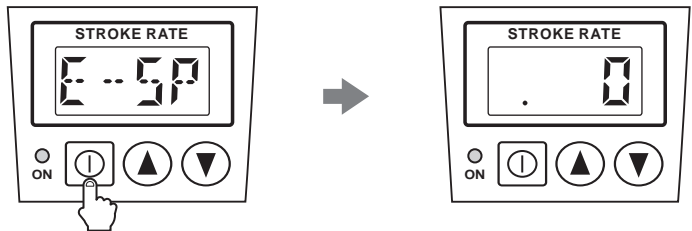

"EXT" appears on the screen when EXT indication is selected.

# STOP function

The start/stop of the pump operation can be controlled by the external stop signal.

- **Operation stop at the stop signal input: "M-OFF"**  
The pump stops while receiving the stop signal.
- **Operation resumption at the stop signal input: "M-ON"**  
The pump runs while receiving the stop signal.

## ■ STOP function setting

### 1 Enter manual mode.

Push the start/stop key to return to manual mode if the pump is in EXT mode.

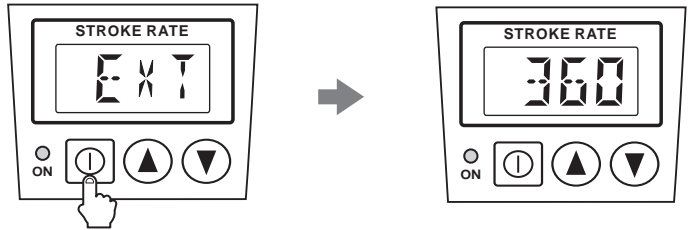

### 2 Push the UP key while pressing the start/stop key to call up the bounce threshold setting mode.

"T-5" (default setting), "T-10" or "T-50" appears on the screen.

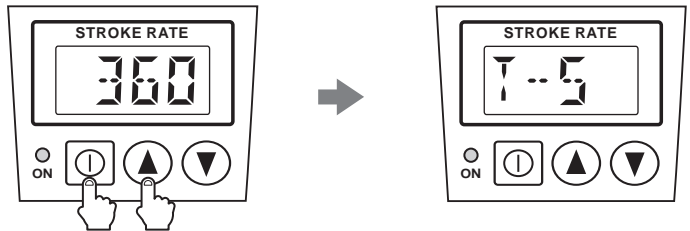

- 3 Push the **DOWN** key and call up the **STOP** function setting mode.  
"M-OFF" (default setting) or "M-ON" appears on the screen.

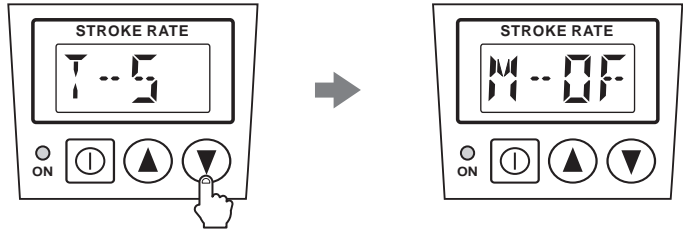

- 4 Push the **UP** key to select "M-OFF" (stop during the signal input) or "M-ON" (run during the signal input).

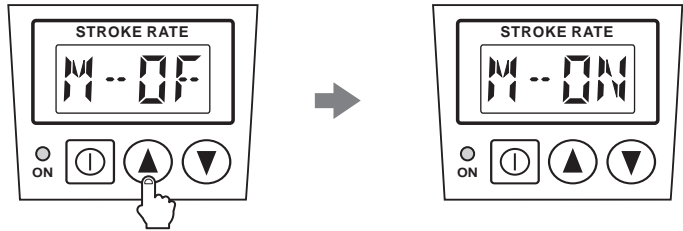

- 5 Push the **start/stop** key to return to manual mode.

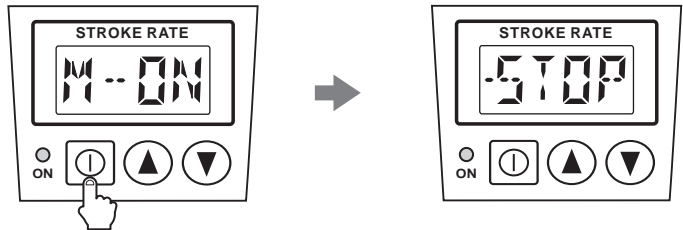

## ■ STOP function cancellation

A stop state can be cancelled if the current selection is changed.

Example) M-OF→M-ON  
M-ON→M-OF

- 1 Enter the stop signal when the pump stops in the manual mode.  
"-STOP" appears on the screen.

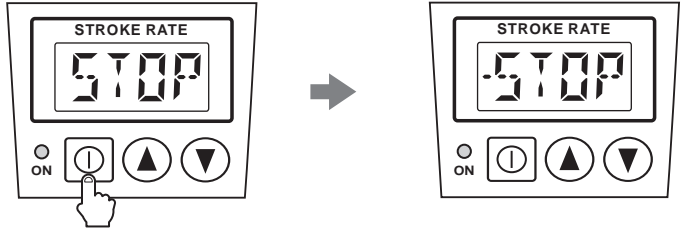

- 2 Push the UP key while pressing the start/stop key to call up the bounce threshold setting mode.

"T-5" (default setting), "T-10", or "T-50" appears on the screen.

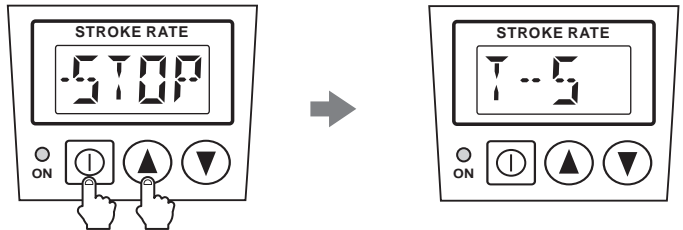

- 3 Push the DOWN key and call up the STOP function selection mode.

"M-OF" (default setting) or "M-ON" appears on the screen.

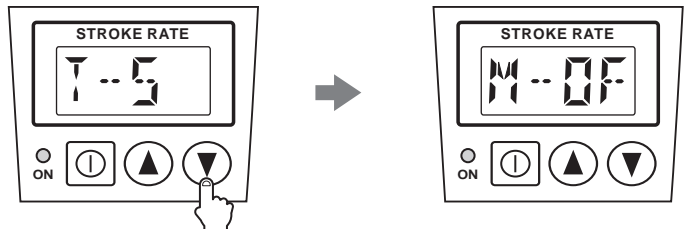

**4 Push the UP key and change the current selection.**

If "M-OFF" is selected, change it to "M-ON". If "M-ON" is selected, change to "M-OFF".

**When "M-OFF" is selected**

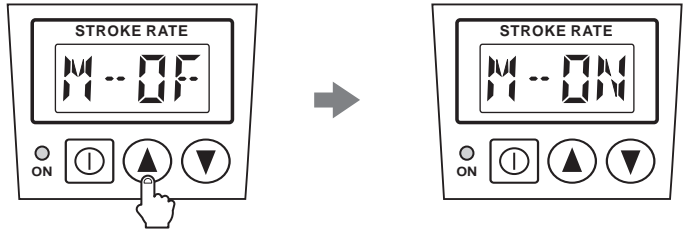

**5 Push the start/stop key to return to the manual mode.**

In this state the pump is stopped.

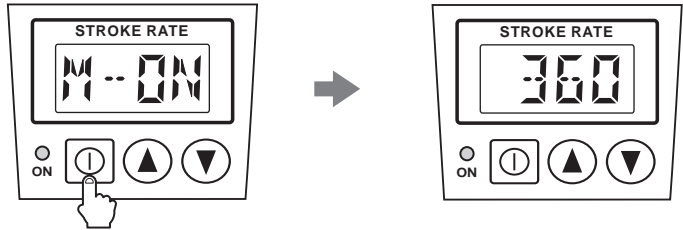

The STOP function now has been cancelled.

## Keypad lock

---

Keypad lock can be active in the following states for the prevention of erroneous key operation.

### Manual mode

Wait state

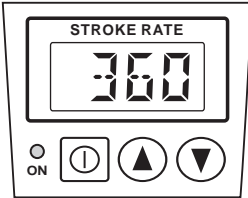

During operation

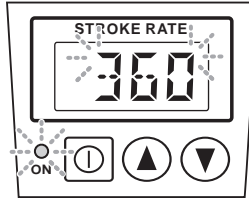

### EXT mode

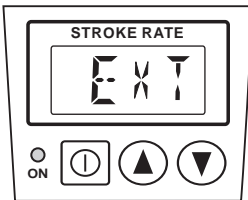

### NOTE

---

- Any key operation is not effective when keypads are locked. In an emergency, turn off the main power to stop operation. Keypads are locked again when the pump is powered.
  - The display shows "STOP" or "-STOP" when the keypads are locked while the pump is receiving the STOP signal. These display will change to the normal (keypad lock info as shown right) once the stop signal is removed.
-

## ■ Keypad lock activation

- 1 Press and hold the start/stop key for three (3) seconds.

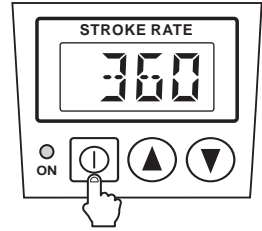

The following indication appears.

**Pump runs in MAN mode**

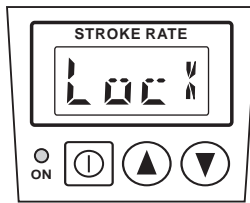

**Pump runs in EXT mode**

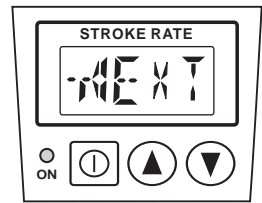

## ■ Keypad lock release

- 1 Press and hold the start/stop key for three (3) seconds.  
Keypad lock is released and key operation becomes effective.

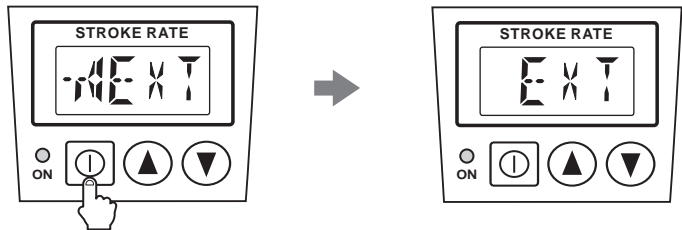

# Maintenance

*This section describes troubleshooting, inspection, wear part replacement, exploded views and specifications.*

## **!** Important

- Follow instructions in this manual for replacement of wear parts. Do not disassemble the pump beyond the extent of the instructions.
- Always wear protective clothing such as an eye protection, chemical resistant gloves, a mask and a face shield during disassembly, assembly or maintenance work. The specific solution will dictate the degree of protection. Refer to MSDS precautions from the solution supplier.
- Risk of electrical shock. Be sure to turn off power to stop the pump and related devices before service is performed.

## **Before unplugging the pump**

Always stop the pump by key operation. And wait for three seconds before unplugging the pump. Otherwise, the last key operation to stop the pump may not be put in memory. In this case the pump unintentionally starts to run as powered on, discharging liquid.



## Troubleshooting

First check the following points. If the following measures do not help remove problems, contact us or your nearest distributor.

States	Possible causes	Solutions
The pump does not run . (LED does not light. Blank screen.)	Power voltage is too low.	<ul style="list-style-type: none"> <li>• Observe the allowable voltage range of 90-264VAC</li> </ul>
	The pump is not powered.	<ul style="list-style-type: none"> <li>• Check the switch if it is installed.</li> <li>• Correct wiring</li> <li>• Replace a broken wire to new one.</li> </ul>
	An electronic circuit in the control unit is failed.	<ul style="list-style-type: none"> <li>• Replace the control unit.</li> </ul>
Liquid can not be pumped up.	Air lock in the pump	<ul style="list-style-type: none"> <li>• Expel air. See page 35.</li> </ul>
	Stroke length is too short.	<ul style="list-style-type: none"> <li>• Run the pump with full stroke length and then with adjusted length.</li> </ul>
	Air ingress through a suction line.	<ul style="list-style-type: none"> <li>• Correct tubing.</li> </ul>
	A valve set is installed upside down.	<ul style="list-style-type: none"> <li>• Reinstall the valve set.</li> </ul>
	Valve gaskets are not installed.	<ul style="list-style-type: none"> <li>• Install valve gaskets.</li> </ul>
	Foreign matters are stuck in the pump head valves.	<ul style="list-style-type: none"> <li>• Take apart, inspect and clean the valves. Replace as necessary.</li> </ul>
Flow rate fluctuates.	A ball valve is stuck on a valve seat.	<ul style="list-style-type: none"> <li>• Take apart, inspect and clean the valve. Replace as necessary.</li> </ul>
	Air stays in the pump head.	<ul style="list-style-type: none"> <li>• Expel air. See page 35.</li> </ul>
	Overfeeding occurs.	<ul style="list-style-type: none"> <li>• Mount a check valve. See page 25.</li> </ul>
	Foreign matters are stuck in the pump head valves.	<ul style="list-style-type: none"> <li>• Dismantle, inspect and clean the valves. Replace as necessary.</li> </ul>
	Diaphragm is broken.	<ul style="list-style-type: none"> <li>• Replace diaphragm.</li> </ul>
	Pressure fluctuates at an injection point.	<ul style="list-style-type: none"> <li>• Maintain a pressure constant at an injection point by optimizing tubing or by relocating the point.</li> </ul>

Liquid leaks.	Loose fit of the fitting or the air vent body.	• Retighten them.
	Loose fit of the pump head.	• Retighten the pump head. See page 35.
	O rings or valve gaskets are not installed.	• Install O rings and valve gaskets in place.
	Diaphragm is broken.	• Replace the diaphragm.
	Excessive discharge pressure.	• Check that a discharge line is not closed. • Check if tubing is not clogged.

## Inspection

Perform daily and periodic inspection to keep pump performance and safety.

### **Daily inspection**

Check the following points. If you notice any abnormal or dangerous conditions, suspend operation immediately and inspect/solve problems. See the troubleshooting section as necessary.

When wear parts come to the life limit, replace them with new ones. Contact us or your nearest distributor for detail.

No.	States	Points to be checked	How to check
1	Pumping	• If liquid is pumped.	Flow meter or visual inspection
		• If the suction and discharge pressure are normal.	Check specifications.
		• If liquid has deteriorated, crystallized or precipitated.	Visual or audio inspection
2	Noise and vibration	• If abnormal noise or vibration occurs. They are signs of abnormal operation.	Visual or audio inspection
3	Air ingress from pump head joints and a suction line	• If leakage occurs. • If pumped liquid includes air bubbles, check lines for leakage and retighten as necessary.	Visual or audio inspection

### **Periodic inspection**

Retighten the pump head mounting bolts evenly to the following torque in diagonal order.

\*Mounting bolts may loosen in operation. How fast the bolts start to loosen is depending on operating conditions.

#### **Tightening torque**

Model code	Torque	Bolts
EHN-B11/-B16/-C16/-C21	2.16 N•m	M4 Hex. socket head bolt

\*A hexagon wrench can be used for a torque wrench. See page 35.





# Wear part replacement

To run the pump for a long period, wear parts need to be replaced periodically. It is recommended that the following parts are always stocked for immediate replacement. Contact us or your nearest distributor for detail.

## ! Precautions

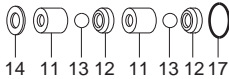
- Solution in the discharge line may be under pressure. Release the pressure from the discharge line before disconnecting plumbing or disassembly of the pump to avoid solution spray.
- Rinse wet ends thoroughly with tap water.
- Each time the pump head is dismantled, replace the diaphragm, O rings, valve gaskets and valve sets with new ones.

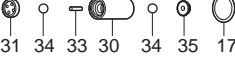
## Wear part list

		Parts	# of parts	Estimated life
Pump	Valve set		2 sets	8000 hours
	Diaphragm		1	
	O ring		See page 76.	
	Auto vent valve set		1 set	
Check valve	Check valve poppet (with an O ring)		1 set	
	Check valve spring		1	

\*Wear part duration varies with the pressure, temperature and characteristics of liquid.  
 \*The estimated life is calculated based on the continuous operation with clean water at ambient temperature.

## ***Before replacement***

---

*First release pressure from the pump head.*

**1 Stop the pump operation.**

**2 Rotate the adjusting screw two revolutions anticlockwise to open the air vent port.**

NOTE

Do not rotate it three revolutions from the closed position. Or liquid may come out from the adjusting screw.

**3 Check the air vent line and the pump head are depressurized.**

Liquid pressure is released from the air vent line in the form of solution spray.

NOTE

If pressurized liquid is not expelled, run the pump with an opened air vent line until pressure is removed.

## ***Valve set replacement***

---

### **■ Discharge valve set disassembly/assembly**

#### **Necessary tools**

- An adjustable wrench or spanner
- A 21mm box wrench
- A pair of tweezers

\*Unfix the pump base before disassembly.

NOTE

Some chemicals may damage skin and dry end parts. Wash/wipe chemicals off immediately if they got wet.

- 1 Loosen the fitting nut to remove the discharge tube and the manu/auto air bleed tubes.

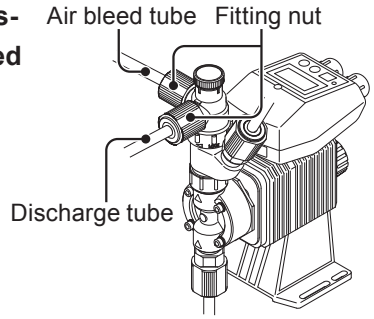

- 2 Turn the lock nut anticlockwise by an adjustable wrench and remove the air vent body A.

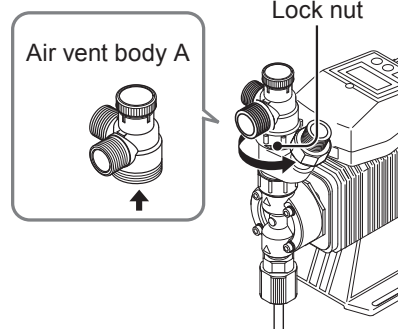

- 3 Remove the air vent body B by the 21mm box wrench.

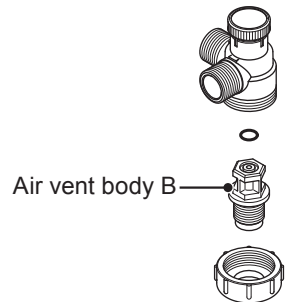

- 4 Pull out the valve set by a pair of tweezers.

**5 Build up the new valve set into the fitting adapter and fasten the air vent body B via the lock nut.**

- \*Arrange the valve set in the correct parts order and direction. A leak or an insufficient flow may result.
- \*Be sure to fit O rings and gaskets in place.
- \*Keep the valve set clean.

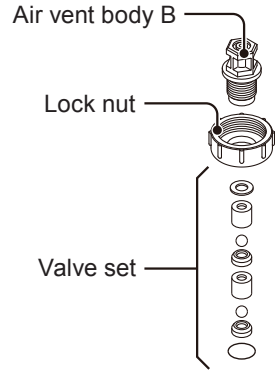

**6 Remount the air vent body A and connect tubes.**

**■ Suction valve set disassembly/assembly**

**NOTE**

Be careful not to drop the valve set.

**1 Remove the fitting nut and the suction tube.**

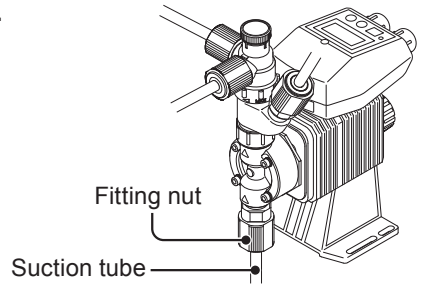

**2 Remove the fitting by an adjustable wrench or a spanner.**

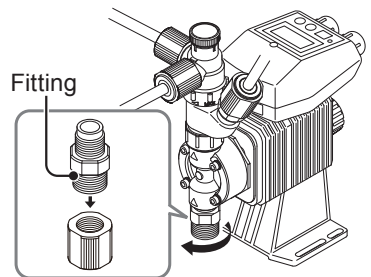

**3 Pull out the valve set by a pair of tweezers.**

**4 Place a new valve set into the fitting. Hand-tighten the fitting into the pump head as far as it will go. Retighten it by a further 1/4 turn with an adjustable wrench or a spanner (3.43N·m).**

\*Arrange the valve set in the correct parts order and direction. A leak or an insufficient flow may result.

\*Be sure to fit O rings and gaskets in place.

\*Keep the valve set clean.

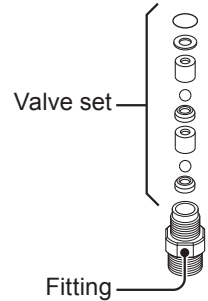

**5 Reconnect the suction tube.**

#### ■ Spacer set disassembly/assembly

**1 Loosen the lock nut and remove the fitting adapter.**

**2 Loosen the air vent body B and take the spacer set out of the pump head.**

**3 Place a new spacer set into the pump head. Screw the air vent body B into the pump head through the lock nut.**

\*Be sure to fit O rings and gaskets in place.

\*Keep the spacer set clean.

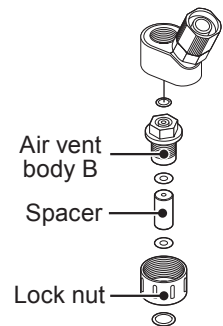



## ■ Auto vent valve set disassembly/assembly

- 1 **Loosen the fitting nut and remove the air bleed tube.**

\*Be careful not to get wet with a residual chemical.

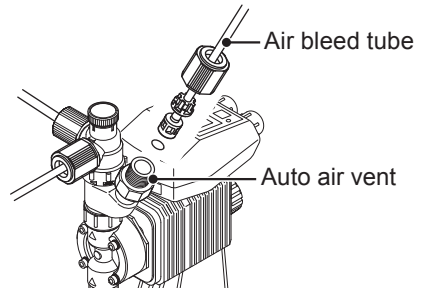

- 2 **Remove the fitting by an adjustable wrench or a spanner.**

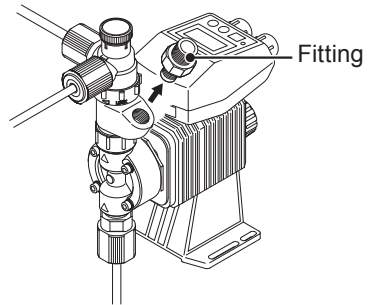

- 3 **Pull out the valve set by a pair of tweezers.**

- 4 **Place a new valve set into the fitting adapter. Hand tighten the fitting into the fitting adapter as far as it will go. Retighten it by a further 1/4 turn with an adjustable wrench or a spanner (2.45N•m).**

\*Arrange the valve set in the correct parts order and direction. A leak or an insufficient flow may result.

\*Be sure to fit O rings and gaskets in place.

\*Keep the valve set clean.

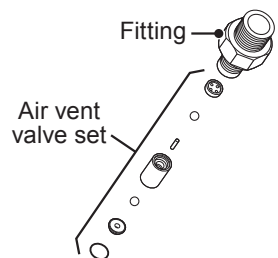

- 5 **Reconnect the air bleed tube.**

# Diaphragm replacement

## Necessary tools

- An adjustable wrench or spanner
- A hexagon wrench
- A torque wrench

## NOTE

Pay attention not to loose diaphragm spacers. A few diaphragm spacers may be inserted between the retainer and plunger for the adjustment of a diaphragm location. Note that the number of diaphragm spacers provided varies at different pumps.

**1 Run the pump and set the stroke length to 0%. Then stop the pump.**

**2 Loosen the fitting nuts and remove the suction tube, discharge tube, and air bleed tube.**

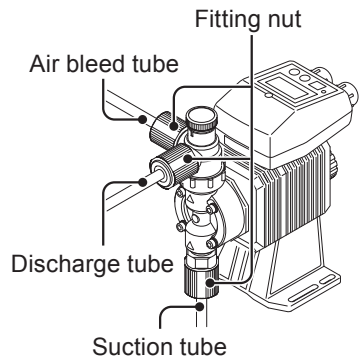

**3 Remove the pump head with a hexagon wrench.**

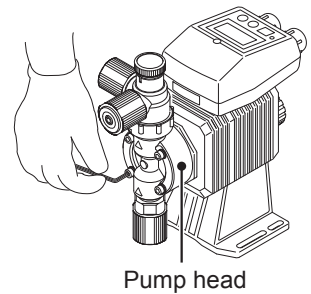

**4 Unscrew the diaphragm from the plunger (pump shaft).**

- 5 **Slide the retainer and diaphragm spacer(s) onto the screw of the new diaphragm.**

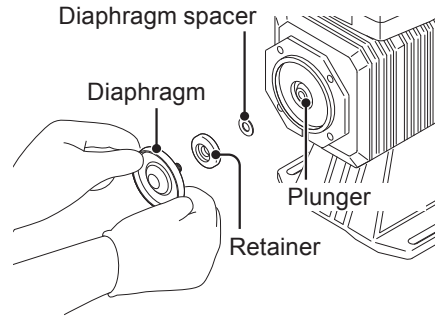

**NOTE**

- Fit the retainer with its round edge to the diaphragm.
- Do not remove the bracket spacer. If removed, replace as shown to the right.

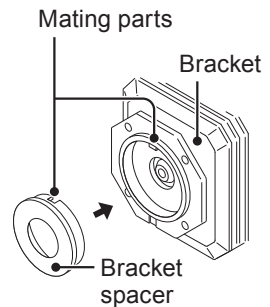

- 6 **Screw the new diaphragm into the plunger as far as it will go.**

- 7 **Run the pump and set the stroke length to 100%.**  
Stop the pump afterwards.

- 8 **Mount the pump head.**  
Tighten the bolts diagonally and evenly by 2.16 N•m at each model.  
\*A hexagon wrench can be used for a torque wrench. See page 35.

# Exploded view

## Pump head, Drive unit & Control unit

Do not disassemble the pump beyond the description in this manual.

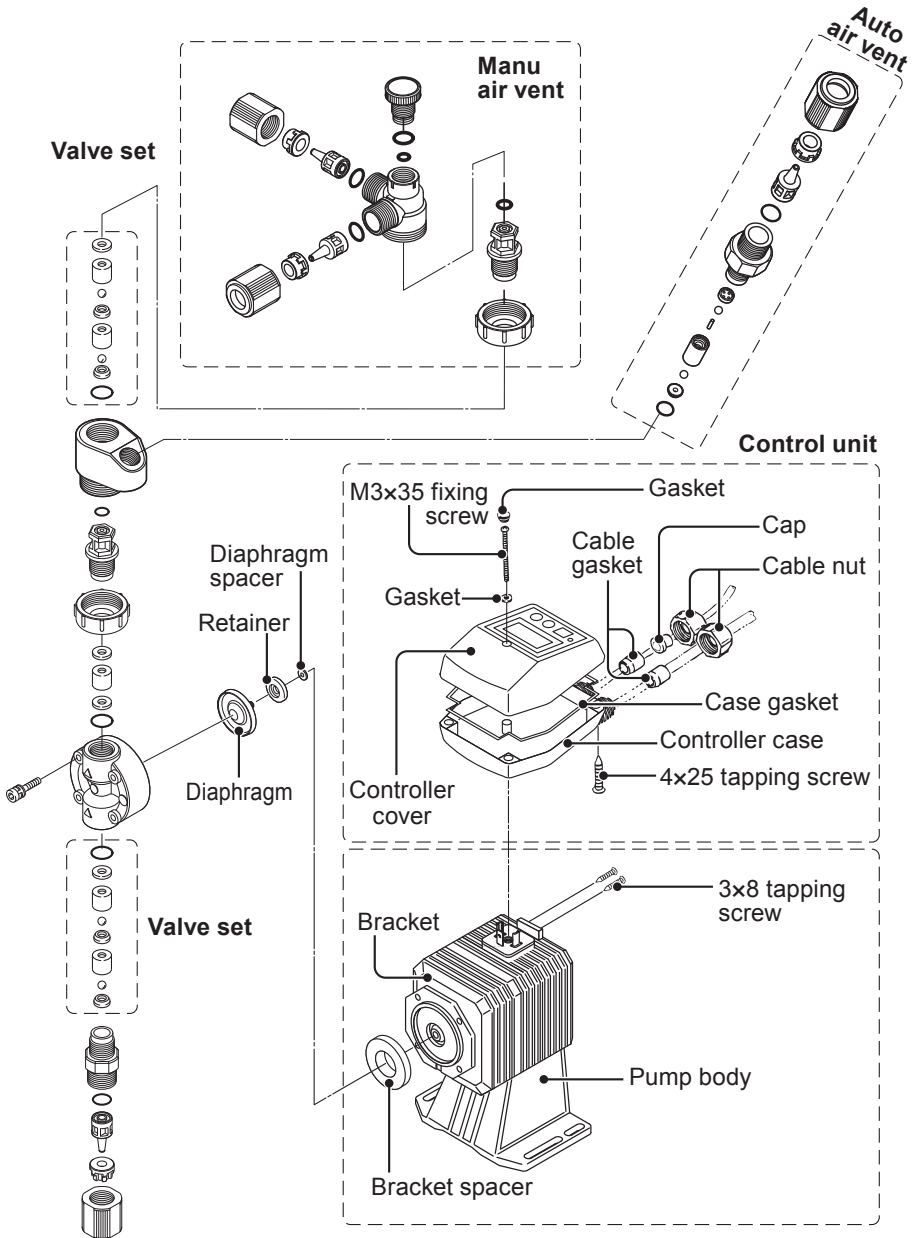

# Pump head

## ■ EHN-B/-C \_ VC/VH

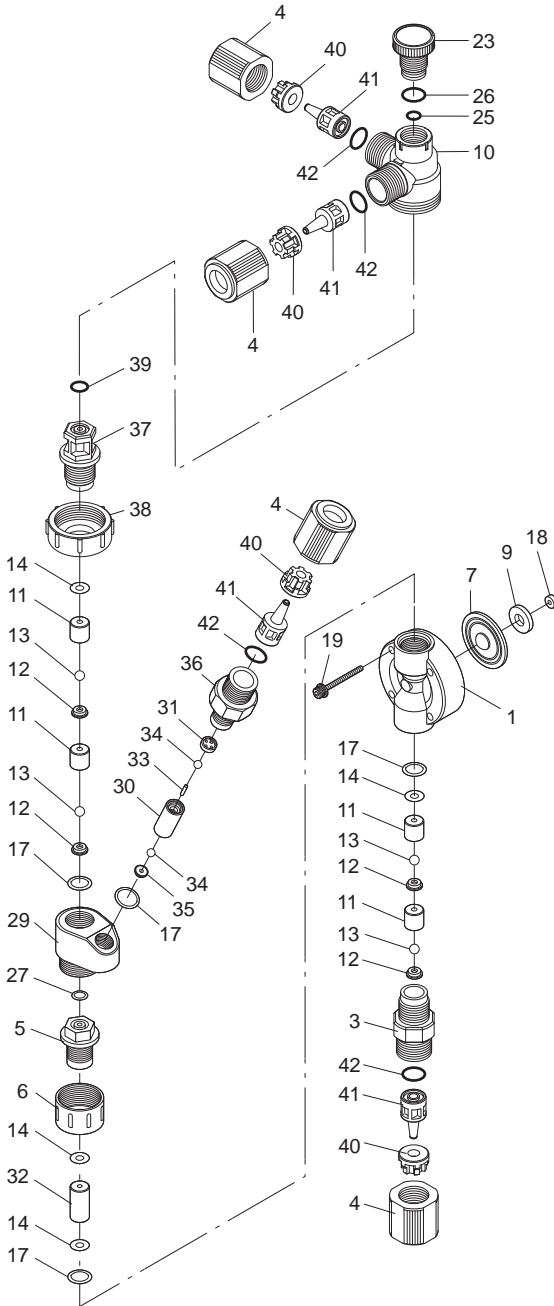

No.	Part names	# of parts
1	Pump head	1
3	Fitting	2
4	Fitting nut	4
5	Air vent body B	1
6	Lock nut	1
7	Diaphragm	1
9	Retainer	1
10	Air vent body A	1
11	Valve guide	4
12	Valve seat	4
13	Valve	4
14	Valve gasket	4
17	O ring (S14)	4
18	Diaphragm spacer	*
19	Hex socket cap bolt [PW•SW]	4
23	Adjusting screw	1
25	O ring (P4)	1
26	O ring (P10A)	1
27	O ring (P7)	2
29	Fitting adapter	1
30	Air vent valve guide A	1
31	Air vent valve guide B	1
32	Spacer	1
33	Separate pin	1
34	Valve	2
35	Valve seat	1
36	Fitting	1
37	Air vent body B	1
38	Lock nut	1
39	O ring	1
40	Hose stopper	4
41	Hose adapter	4
42	O ring	4

\*The number of diaphragm spacers varies with pump model.

## Check valve

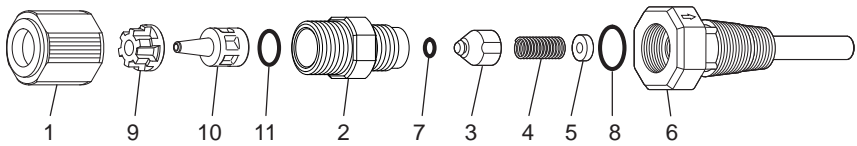

No.	Part names	# of parts
1	Fitting nut	1
2	Valve case	1
3	Poppet	1
4	Spring	1
5	Spacer	1
6	Valve fitting A	1
7	O ring	1
8	O ring	1
9	Hose stopper	1
10	Hose adapter	1
11	O ring	1

### Specifications

Information in this section is subject to change without notice.

#### ■ Pump unit

Model code	Flow rate ml/min	Max. discharge pressure MPa	Stroke length mm (%)	Stroke rate spm	Tube size mm	Current value A	Power consumption W	Weight kg
EHN-B11	30	1.0	0.5-1.0 (50-100)	1 - 360	ø4×ø9	0.8	20	1.8
EHN-B16	55	0.7						
EHN-C16	65	1.0	0.5-1.25 (40-100)			1.2	24	2.9
EHN-C21	110	0.7						

\*The above information is based on pumping clean water at ambient temperature and the rated voltage.

\*Flow rates were collected at the maximum discharge pressure, 100% stroke length and 360spm. A flow rate increases as a discharge pressure decreases.

\*Allowable room temperature: 0-40°C

\*Allowable liquid temperature: 0-40°C

\*Allowable power voltage deviation: ±10% of the rated voltage

## ■ Control unit

Operation mode	Mode	Manual
		EXT (multiplier or divisor)
Stroke rate	Mode selection	Key operation
	Setting range	1-360spm
STOP function	spm setting	UP and DOWN keys
	M-OFF	The pump stops during contact input.
	M-ON	The pump runs during contact input.
EXT mode	Input signal	No-voltage contact or open collector*1
	Max spm	Manual speed
	Pump behaviour	n shots per signal (multiplier)*2 n signals per shot (divisor)*3 1:1 operation with n=1
	Input signal	No-voltage contact or open collector*1
Monitors	Divisor/Multiplier range	1-999 (divisor or multiplier selection)
	LCD	4-digit LCD
	LED	Green LED×1 (blinks at each shot)
Buffer		Non-volatile memory
Power voltage*4		100-240VAC 50/60Hz

\*1 The maximum applied voltage from the EHN-NAE to an external contact is 12V at 5mA. When using a mechanical relay, the minimum application load should be 5mA or below.

\*2 In the operation with the multiplier, external signals that have not been processed are stored up to 255 pulses.

\*3 In the operation with the divisor, external signals entered to run the pump over the MAN speed are cancelled.

\*4 Observe the allowable power voltage range of 90-264VAC. Or failure may result.

## ■ Power cable

Conduction section area	0.75 [mm <sup>2</sup> ] duplex cable
Length	1500 [mm]
Standard	VCTFK
Terminal treatment	Spade terminal (V1.25-YS4A or equivalent)

## ■ Pump colour

Blue	Munsell colour system 7.5PB 3/8
Red	Munsell colour system 5R 3/10



## ■ Check valve

Model code	Set pressure MPa	Connection size mm	Wet ends	Applicable pump models	Wet end codes
CAN-1VC-M	0.17	ø4×ø9/ø4×ø6	PVC	EHN-B11/-B16 EHN-C16/-C21	VC
CAN-1VE-M					VH

# Outer dimensions

## ■ EHN-B11/-B16 VC/VH-NAE

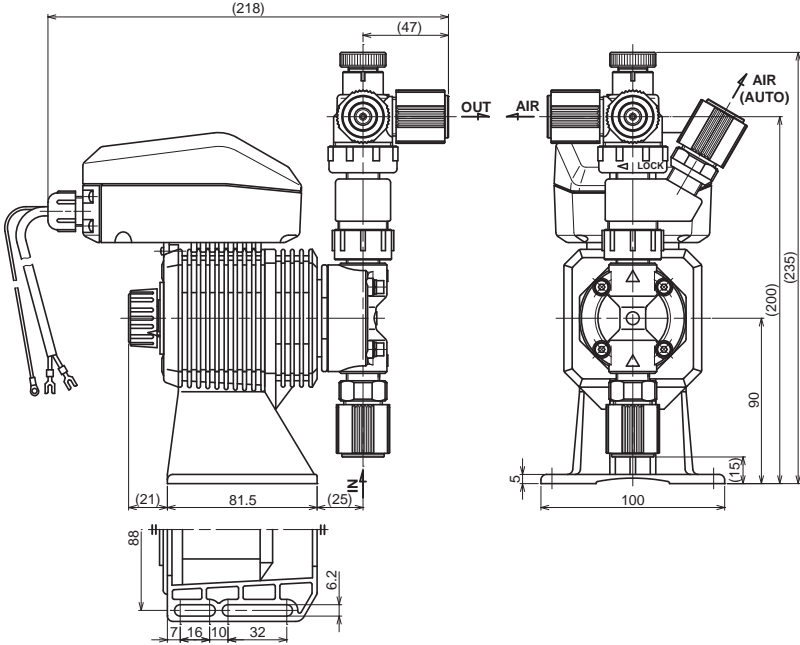

## ■ EHN-C16/-C21 VC/VH-NAE

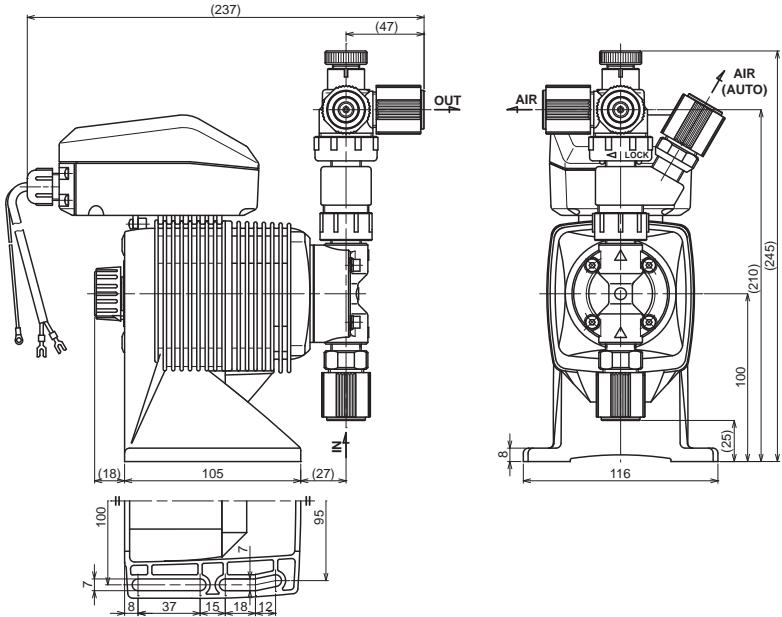



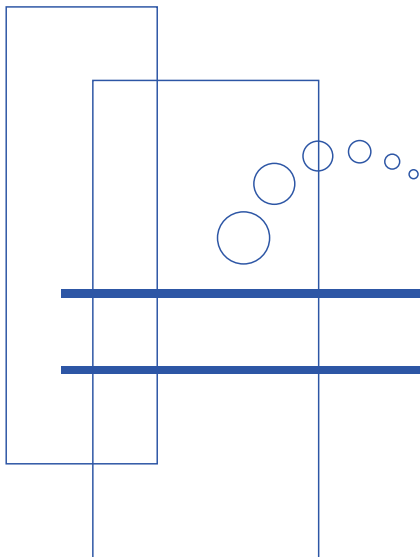

<http://www.iwakipumps.jp>



IWAKI CO.,LTD. 6-6 Kanda-Sudacho 2-chome Chiyoda-ku Tokyo 101-8558 Japan  
TEL: +81 3 3254 2935 FAX: +81 3 3252 8892

**European office** / IWAKI Europe GmbH  
TEL: +49 2154 9254 0 FAX: +49 2154 9254 48

**Germany** / IWAKI Europe GmbH  
TEL: +49 2154 9254 50 FAX: +49 2154 9254 55

**Holland** / IWAKI Europe GmbH (Netherlands Branch)  
TEL: +31 74 2420011 FAX: +49 2154 9254 48

**Italy** / IWAKI Europe GmbH (Italy Branch)  
TEL: +39 0444 371115 FAX: +39 0444 335350

**Spain** / IWAKI Europe GmbH (Spain Branch)  
TEL: +34 93 37 70 198 FAX: +34 93 47 40 991

**Belgium** / IWAKI Belgium N.V.  
TEL: +32 13 670200 FAX: +32 13 672030

**Denmark** / IWAKI Nordic A/S  
TEL: +45 48 242345 FAX: +45 48 242346

**Finland** / IWAKI Suomi Oy  
TEL: +358 9 2745810 FAX: +358 9 2742715

**France** / IWAKI France S.A.  
TEL: +33 1 69 63 33 70 FAX: +33 1 64 49 92 73

**Norway** / IWAKI Norge AS  
TEL: +47 23 38 49 00 FAX: +47 23 38 49 01

**Sweden** / IWAKI Sverige AB  
TEL: +46 8 511 72900 FAX: +46 8 511 72922

**U.K.** / IWAKI Pumps (U.K.) LTD.  
TEL: +44 1743 231363 FAX: +44 1743 366507

**U.S.A.** / IWAKI America Inc.  
TEL: +1 508 429 1440 FAX: +1 508 429 1386

**Argentina** / IWAKI America Inc. (Argentina Branch)  
TEL: +54 11 4745 4116

**Singapore** / IWAKI Singapore Pte Ltd.  
TEL: +65 6316 2028 FAX: +65 6316 3221

**Indonesia** / IWAKI Singapore (Indonesia Branch)  
TEL: +62 21 6906606 FAX: +62 21 6906612

**Malaysia** / IWAKIm SDN. BHD.  
TEL: +60 3 7803 8807 FAX: +60 3 7803 4800

**Australia** / IWAKI Pumps Australia Pty Ltd.  
TEL: +61 2 9899 2411 FAX: +61 2 9899 2421

**China** (Hong Kong) / IWAKI Pumps Co., Ltd.  
TEL: +852 2607 1168 FAX: +852 2607 1000

**China** (Guangzhou) / GFTZ IWAKI Engineering & Trading Co., Ltd.  
TEL: +86 20 84350603 FAX: +86 20 84359181

**China** / IWAKI Pumps (Shanghai) Co., Ltd.  
TEL: +86 21 6272 7502 FAX: +86 21 6272 6929

**Korea** / IWAKI Korea Co., Ltd.  
TEL: +82 2 2630 4800 FAX: +82 2 2630 4801

**Taiwan** / IWAKI Pumps Taiwan Co., Ltd.  
TEL: +886 2 8227 6900 FAX: +886 2 8227 6818

**Thailand** / IWAKI (Thailand) Co., Ltd.  
TEL: +66 2 322 2471 FAX: +66 2 322 2477

**Vietnam** / IWAKI Pumps Vietnam Co., Ltd.  
TEL: +84 613 933456 FAX: +84 613 933399