

IWAKI

Pneumatic Drive Bellows Pump

FF-H

Instruction Manual

⚠ Read this manual before use of product

Thank you for selecting an Iwaki Pneumatic Drive Bellows Pump the FF-H. This instruction manual deals with “*Safety instructions*”, “*Outline*”, “*Installation*”, “*Operation*” and “*Maintenance*” sections. Please read through this manual carefully to ensure the optimum performance, safety and service of your pump.

Contents

Important instructions	1
Safety instructions	2
<i>Outline</i>	
1. Unpacking & Inspection	6
2. Operating principle	6
3. Model codes	7
4. Specifications	7
5. Outer dimensions	8
6. Part names	9
7. Overview	11
<i>Installation</i>	
1. Before installation	13
2. Installation/Piping/Wiring	15
<i>Operation</i>	
1. Before operation	28
2. Operation	28
3. Check items	29
<i>Maintenance</i>	
1. Troubleshooting	31
2. Maintenance & Inspection	33
3. Wear parts	34



This instruction manual should be kept on hand by the end user for quick reference.

Contact us or your nearest dealer if you have any questions.

Important instructions

For the Safe and Correct Handling of the pump

- "Safety Instruction" section deals with important details about handling of the product. Before use, read this section carefully for the prevention of personnel injury or property damage.
- Observe the instructions accompanied with "WARNING" or "CAUTION" in this manual. These instructions are very important for protecting pump users from dangerous situations.
- The symbols on this instruction manual have the following meanings:

 WARNING	Nonobservance or misapplication of the contents of "Warning" section could lead to a serious accident which may result in death.
 CAUTION	Nonobservance or misapplication of the contents of "Caution" section could lead to the personal injury to users or serious damage to the product.

Types of Symbols



Indicates that "Warning" or "Caution" must be exercised. Inside this triangle, a concrete and practical image provided as a warning or caution message is depicted.



Indicates a prohibited action or procedure. Inside or near this circle, a concrete and practical image of the activity to be avoided is depicted.



Indicates an important action or procedure which must be performed or carried out without fail. Failure to follow the instructions herein can lead to malfunction or damage to the pump.

Safety instructions

WARNING

- **When turning on power**

Make sure there is no one around the pump when connecting the power cable. Any power supply switch is not provided on the pump. Connecting the power cable, a solenoid valve starts to supply air to run the pump.



- **Do not remodel the pump**

Never remodel the pump. We are not responsible for any injury or damage due to modification.



- **Specified application only**

Use of the pump in any application other than those clearly specified may result in a personal injury or property damage.



- **Drainage**

Do not drain chemicals directly onto the ground or a waste channel. Disposal of chemicals should be in accordance with an applicable law.



- **Do not come in contact with the pump**

Risk of burn. The surface temperature of the pump and piping may rise high. Always wear protective gloves when liquid temperature is more than 50°C.



CAUTION

- **Observe the specified voltage**

Risk of a fire or electrical shock. Do not supply any power voltage other than specified one.



- **Before maintenance**

Rinse the pump with pure water. Be sure to wear protective gear (protective goggles, cap, mask and acid-resistant gloves).



- **Qualified operator only**

The pump must be handled by a qualified operator(s) who has trained in the safe operation of the pump.



- **Use a strong chain or rope to lift the pump up**

Otherwise the pump may accidentally fall down, resulting in serious injury or death.



- **Before use**

Rinse the pump with pure water or a liquid to be sent.



- **Countermeasure against efflux**

Take a protective measurement against accidental chemical efflux and splash at pump or piping breakage. Also, take an appropriate measurement to prevent accidental outflow from directly soaking into the ground.



Safety instructions

CAUTION

• Power OFF

Be sure to turn off the power before a maintenance/repair work. Make sure no one turns on the power while working on the pump, otherwise a serious accident may result. If your work field is noisy or dark, let other people know about the situation by displaying a notice such as "POWER OFF(Maintenance)" near the power switch.



• Storage limit

Risk of fire and/or health damage. Do not instal or store the pump in the following places under...

- Flammable atmosphere
- Heavy dust
- Corrosive gas (such as chlorine gas)



• Ventilation

Keep good ventilation when handling a toxic/odorous liquid. Always wear protective gear (protective mask, goggles and gloves, etc.).



• Pump disposal

Dispose of an used or damaged pump in accordance with local laws and regulations. Consult a licensed industrial waste products disposing company.



• Returning the pump

Drain a chemical and rinse the wet ends for safe transportation before returns.



• Observe the maximum stroke rate

Operation above the maximum stroke rate (FF-10H & -20H: 120spm, FF-40H: 80spm) may reduce the life of bellows. Set the controller not to run over the maximum stroke rate even under dry running.



• Observe the maximum supply air pressure

Do not set the supply air pressure over 0.196MPa. Otherwise the bellows may deform. Stop the pump before setting the supply air pressure.



• Observe the liquid temperature range

- FF-H: 20 - 180°C

A sharp liquid temperature change (heat shock) may significantly reduce the life of the pump. Contact us for detail.



• Observe the ambient temperature range

- 0 - 40°C



Safety instructions

CAUTION

- **Do not run the pump with the following liquid**

- Liquid easily crystallizes
- Slurry
- Low conductivity hydrocarbon liquid



- **Liquids to be handled with care**

- Stripper
- Solvent (The pump must be in explosion proof.)
- Hydrazine
- Fuming sulfuric acid



- **When stopping the pump**

- Before stopping the pump, release discharge pressure. Otherwise, the bellows may deform due to residual pressure.
- Do not close a discharge valve as stopping the pump. An impact pressure may deform the bellows or a connecting plate.



- **After stopping the pump**

- Do not supply air to both the right and left air-supply ports at once to prevent the bellows deformation.
- Do not leave the pump with any chemical in the bellows for a long period. Some chemical can penetrate the bellows and corrode metal parts. Run the pump for ten minutes every day for replacing air.



- **Air exhaust port**

Do not narrow an air exhaust line (for example by reducing the tube bore). The residual pressure in the pump may deform the bellows.



- **During pump operation**

Make sure all suction and discharge valves are open in order to fill the lines with liquid.



- **Electrodes**

The electrode occasionally fails to detect leakage depending on operating condition. Contact us for detail.



- **Static electricity**

When low electric conductivity liquids such as ultra-pure water and fluor inactive liquid (e.g. Fluorinert™) are handled, the static electricity may be generated in the pump and may cause static discharge. Take countermeasures to remove the static electricity.



Outline

<i>1. Unpacking & Inspection</i>	6
<i>2. Operating principle</i>	6
<i>3. Model codes</i>	7
<i>4. Specifications</i>	7
<i>5. Outer dimensions</i>	8
<i>6. Part names</i>	9
<i>7. Overview</i>	11

Outline

1. Unpacking & Inspection

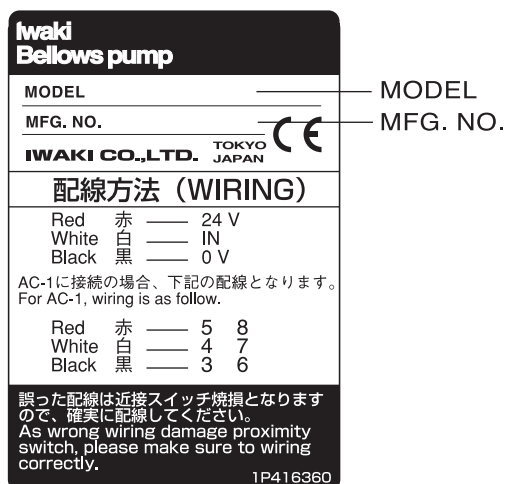

On unpacking the product, check the following points. If you find any problems, contact your nearest dealer.

1. Check the information on nameplate to see if the product is delivered as per order.
2. Check for transit damage, deformation and loose bolts.
3. If all accessories are delivered as per order.
 - a. Controller
(The AC-1, FD, SC and FDC-1)
 - b. Quick exhaust valves

Wiring work is different at each controller type.

2. Operating principle

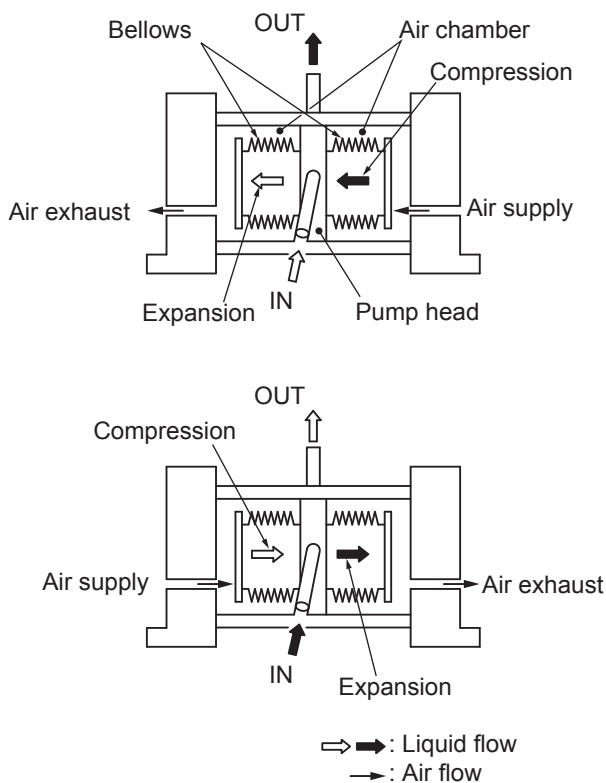

Expansion/compression: Bellows reciprocating motion

An Iwaki pneumatic drive bellows pump has fluorocarbon wet ends and is designed for semiconductor manufacturing processes.

The pump unit has two air chambers and a pair of bellows. The reciprocating motion of the bellows in the air chambers makes suction and discharge actions.

- a. Liquid is sucked via the inlet as the bellows expands.
- b. Liquid is discharged via the outlet as the bellows contracts.

Outline

3. Model codes

FF - 10 H T - S
a b a c d

a. Series code

FF-H: High liquid temperature

b. Maximum flow rate

10 : 10 L/min

20 : 20 L/min

40 : 40 L/min

c. Pump connection (Inlet/Outlet)

T : Tube (standard)

S : Screw

d. Special specifications

No symbol: Standard

S : Special specifications

4. Specifications

	Item	FF-10H	FF-20H	FF-40H
General	Max. flow rate*1	10 L/min	20 L/min	40 L/min
	Max. stroke rate	120 spm		80spm
	Suction lift*2	1m	2m	
	Liquid temperature range*3	20-180°C		
	Max. supply air pressure	0.196MPa		
	Wet ends	PFA, PTFE		
	Pump connection*4 (Tube or Screw)	PFA 1/2" tube (O.D. 12.7 × I.D. 9.52 mm)	PFA 3/4" tube (O.D. 19.05 × I.D. 15.83 mm)	PFA 1" tube (O.D. 25 × I.D. 22 mm)
	Supply air connection	Rc 1/4"		Rc 3/8"
	Max. air consumption (at max. flow rate)	80NI/min	150NI/min	200NI/min
	Ambient temperature	0-40°C		
	Driving method	Pneumatic drive		
Proximity switch	Model	High-frequency proximity switch		
	Output	NPN DC open/close output		
	Power voltage	10-30VDC		
	Cord length	1m		

*1. The maximum flow rate is based on pumping ambient clean water.

*2. The suction lift is based on pumping ambient clean water at the maximum spm.

*3. Use the SC controller in order to control the differential pressure (the supply air pressure minus the discharge pressure) and stroke rate when the liquid temperature range is 160-180°C.

*4. Connection tubes and nuts are attached to the screw connection.

Outline

5. Outer dimensions

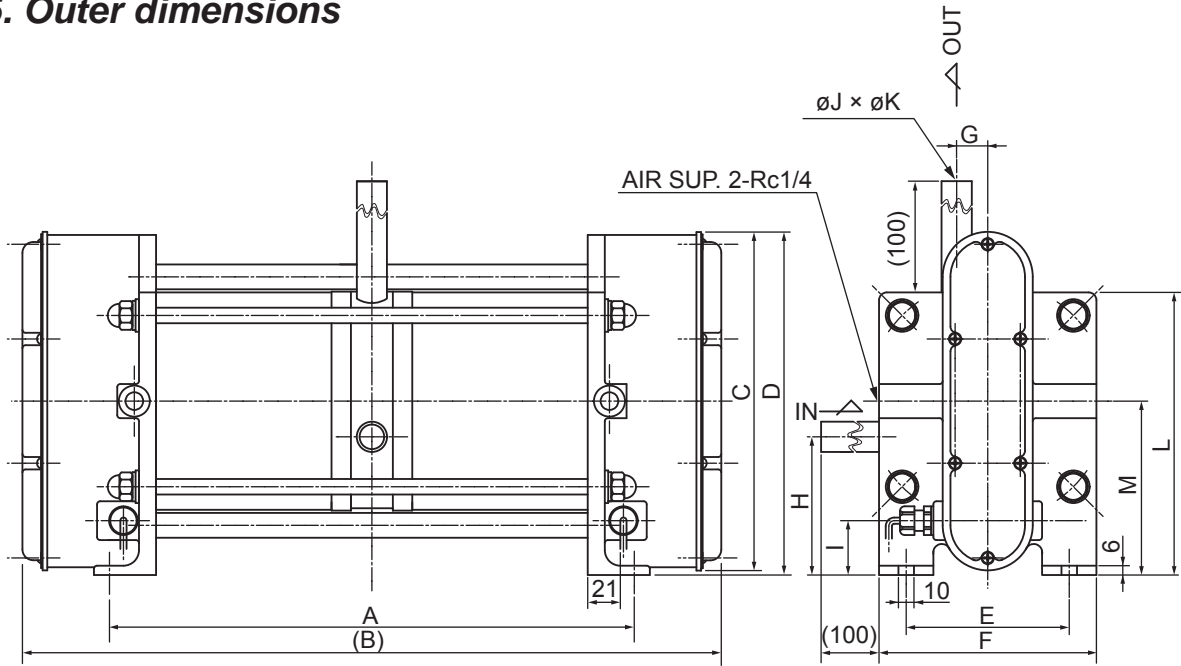

Unit:mm

	A	B	C	D	E	F	G	H	I	øJ×øK	L	Mass
FF-10H	266	361	188	191	84	114	14.5	82	32	ø12.7×ø9.52	154	7.5kg
FF-20H	288	400	218	221	105	140	20	91	35	ø19.05×ø15.83	182	11.5kg

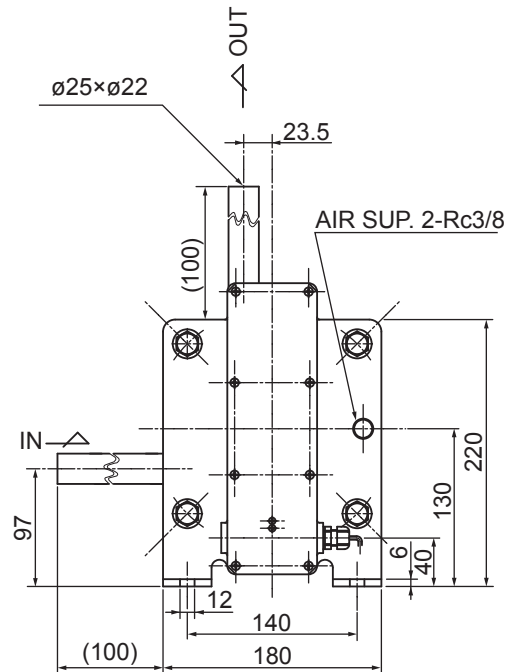
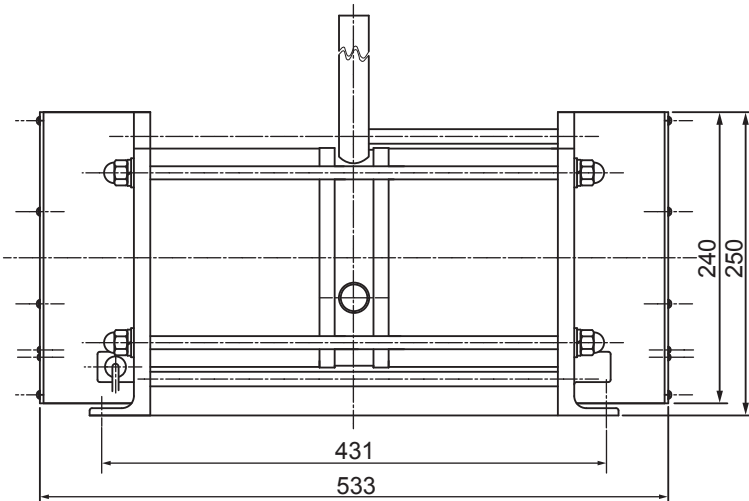
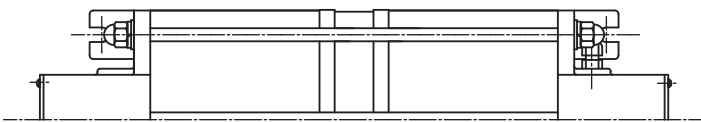

Weight : 24kg

Outline

6. Part names

FF-10HT & -20HT

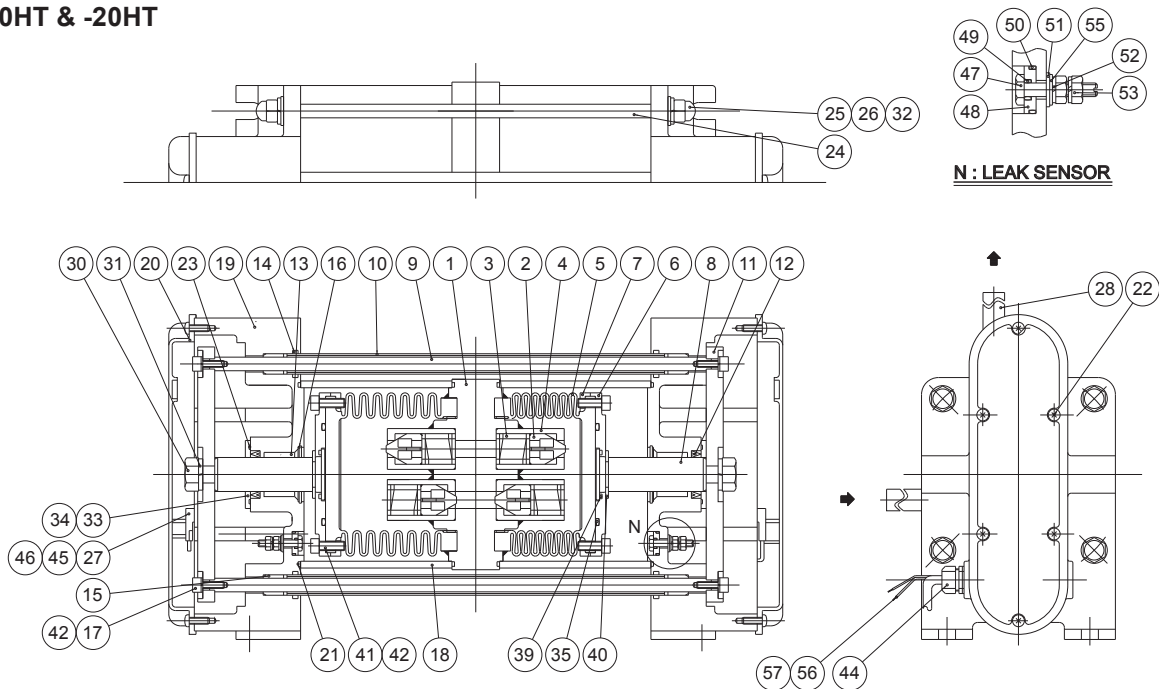

No.	Part names	Q'ty	Materials	Remarks	Q'ty	Part names	Q'ty	Materials	Remarks
1	Pump head	1	PTFE		27	Proximity switch	2	—	
2	Valve	4	PFA		28	Tube	2	PFA	
3	Valve spring	4	PFA		30	Hex. nut	2	Stainless steel	
4	Valve case	4	PFA		31	Spring washer	2	Stainless steel	
5	Bellows	2	PTFE		32	Spring washer	8	Stainless steel	4F coating
6	Bellows plate	2	SUS304		33	Packing stopper	2	SUS304	
7	Bellows flange	4	SUS304		34	Screw	8	Stainless steel	
8	Pump shaft	2	SUS304	Hard chrome plating	35	O ring	2	FKM	
9	Connecting shaft	2	SUS304		39	O ring	2	FKM	S-25
10	Shaft cover	2	SUS304	4F coating	40	Stop ring	2	Stainless steel	E-15
11	Connecting plate	2	SUS304		41	Hex.soch. cap. bolt	12	Stainless steel	M5×15
12	Shaft packing	2	FKM		42	Spring washer	16	Stainless steel	M5
13	Bearing	2	Filled PTFE		44	Cord gland	2	PP	SCL-6A
14	O ring	4	FKM		45	Screw	4	Stainless steel	
15	Guide bush	4	POM		46	Installed base	2	PP	
16	Stop ring	2	SUS304		47	Leak sensor	4	SUS 304	
17	Hex. soch cap bolt	4	Stainless steel	M5×15	48	Gasket	4	PTFE	
18	Cylinder	2	A6063	4F coating	49	O ring	4	FKM	S-4
19	Cylinder head	2	ADC12	4F coating	50	O ring	4	FKM	S-12
20	Cylinder head cover	2	PPE		51	Gasket C	4	PTFE	
21	Gasket	4	FKM		52	Spring washer	8	Stainless steel	M4
22	Screw	12	Stainless steel	M4×8 4F coating	53	Hex. nut	8	Stainless steel	M4
23	Packing	2	FKM		55	Plate washer	4	Stainless steel	M4
24	Stud bolt	4	SUS 304	4F coating	56	Cord (Black)	2	—	
25	Domed cap nut	8	Stainless steel	4F coating	57	Cord (White)	2	—	
26	Plate washer	8	Stainless steel	4F coating					

Outline

FF-40HT

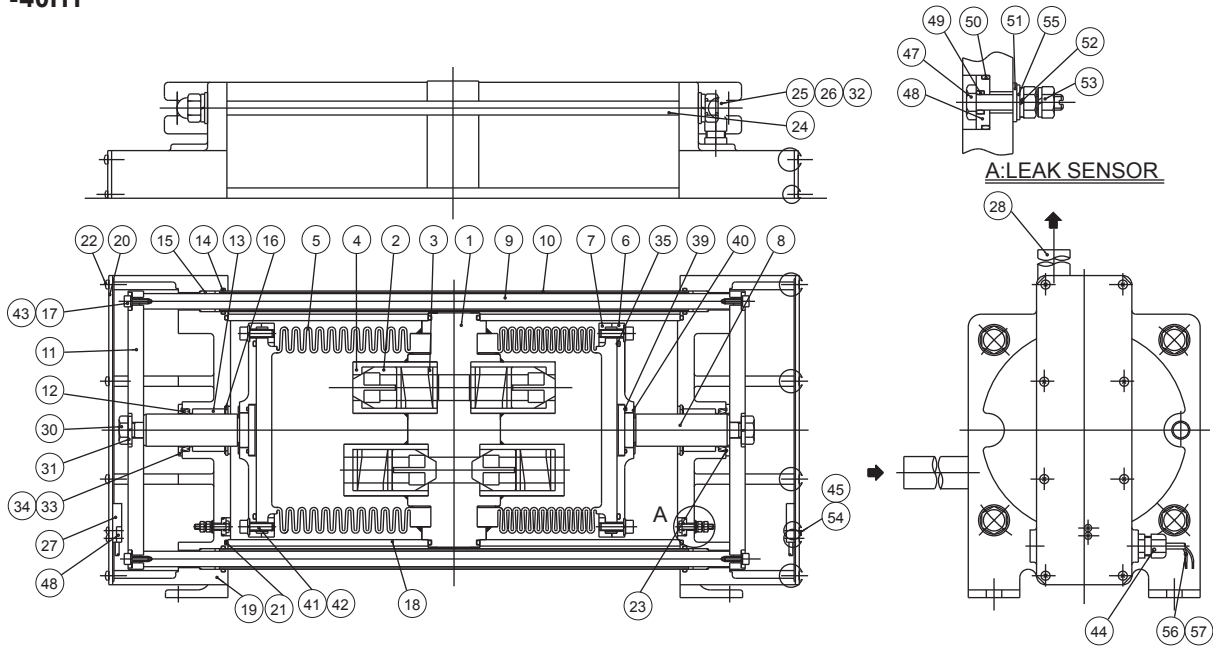

No.	Part names	Q'ty	Materials	Remarks	Q'ty	Part names	Q'ty	Materials	Remarks
1	Pump head	1	PTFE		28	Tube	2	PFA	
2	Valve	4	PFA		30	Hex. nut	2	Stainless steel	M12
3	Valve spring	4	PFA		31	Spring washer	2	Stainless steel	M12
4	Valve case	4	PTFE		32	Spring washer	8	Stainless steel	M12 4F coating
5	Bellows	2	PTFE		33	Packing stopper	2	SUS304	
6	Bellows plate	2	SUS304		34	Screw	8	Stainless steel	M4×8
7	Bellows flange	4	SUS304		35	O ring	2	FKM	G-130
8	Pump shaft	2	SUS304	Hard chrome plating	39	O ring	2	FKM	S-32
9	Connecting shaft	2	SUS304		40	Stop ring	2	Stainless steel	E-19
10	Shaft cover	2	SUS304	4F coating	41	Hex.soch. cap. bolt	16	Stainless steel	M6×20
11	Connecting plate	2	SUS304		42	Spring washer	16	Stainless steel	M6
12	Shaft packing	2	FKM		43	Spring washer	4	Stainless steel	M5
13	Bearing	2	Filled PTFE		44	Cork gland	2	PP	SCL-6A
14	O ring	4	FKM	P-16	45	Screw	4	Stainless steel	M3×10
15	Guide bush	4	POM		46	Installed base	2	SUS 304	
16	Stop ring	2	SUS304	Nominal 37	47	Leak sensor	4	SUS 304	
17	Hex. soch cap bolt	4	Stainless steel	M5×15	48	Gasket	4	PTFE	
18	Cylinder	2	A6063	4F coating	49	O ring	4	FKM	S-4
19	Cylinder head	2	ADC12	4F coating	50	O ring	4	FKM	S-12
20	Cylinder head cover	2	PVC		51	Gasket C	4	PTFE	
21	O ring	4	FKM	172×3	52	Spring washer	8	Stainless steel	M4
22	Screw	16	Stainless steel	M4×8 4F coating	53	Hex. nut	8	Stainless steel	M4
23	Packing	2	FKM		54	Spring washer	4	Stainless steel	M3
24	Stud bolt	4	SUS 304	4F coating	55	Plate washer	4	Stainless steel	M4
25	Domed cap nut	8	Stainless steel	M12 4F coating	56	Cord (Black)	2	—	
26	Plate washer	8	Stainless steel	M12 4F coating	57	Cord (White)	2	—	
27	Proximity switch	2	—						

Outline

7. Overview

⚠ CAUTION

Do not wipe the labels or the pump body with solvent.

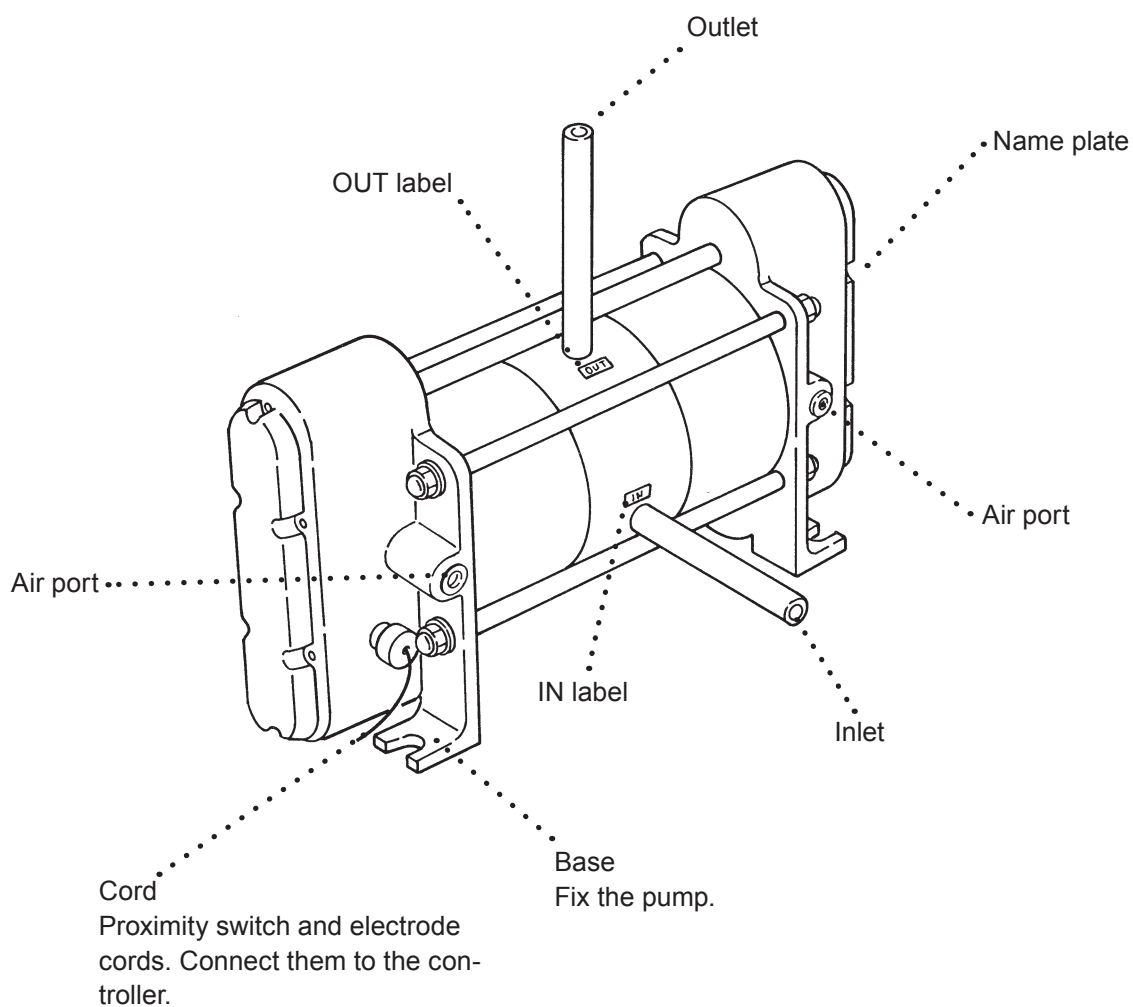

Installation

<i>1. Before installation</i>	<i>13</i>
<i>2. Installation/Piping/Wiring.....</i>	<i>15</i>

Installation

1. Before installation

Read the following precautions thoroughly before operation in order to ensure the safe operation of the pump and system.

To operate this pump, a solenoid valve and a controller (the AC-1, FD, SC or FDC-1 controller) are required. In addition, quick exhaust valves need to be installed in order to enhance system safety. Purchase separately.

#	Points to be checked	Description
1	<ul style="list-style-type: none"> ○ Observe the maximum stroke rate FF-10H & -20H: 120spm FF-40H: 80spm 	<ul style="list-style-type: none"> ● If many bubbles enter the pump, air lock may occur. In this state the pump runs dry and stroke rate increases to an abnormal level. Set your controller not to run the pump over the maximum spm. The maximum spm can be programmed to the FD and SC controllers
2	<ul style="list-style-type: none"> ○ Do not run the pump over 0.196MPa. 	<ul style="list-style-type: none"> ● Reduce the supply air pressure as much as possible for protecting the filter and bellows. ● Flow rate changes with supply air pressure. Install a pressure reducing valve to stabilize the pressure. ● Always stop the pump before setting a supply air pressure.
3	<ul style="list-style-type: none"> ○ Observe liquid temperature range • 20-180°C 	<ul style="list-style-type: none"> ● When a liquid temperature is between 160-180°C... Keep the differential pressure (the supply air pressure minus the discharge pressure) 0.12MPa or below and the stroke rate 80 spm or below for the FF-10H & -20H (or 60spm or below for the FF-40H.). Also, keep the following flow rate. FF-10H : 7L/min FF-20H : 15L/min FF-40H : 30L/min See the instruction manual of the SC. ● Sharp liquid temperature change (heat shock) may significantly reduce the life of bellows. Contact us for detail.
4	<ul style="list-style-type: none"> ○ Prohibited liquids ⚠ CAUTION Do not use... • Liquids that easily crystallize • Slurry • Low conductivity hydrocarbon liquid 	<ul style="list-style-type: none"> ● The life of valves & bellows will shorten when handling a liquid which easily crystallizes or slurry. ● If a low conductivity hydrocarbon liquid is used, electrostatic destruction may result between fluororesin & liquid, finally producing pinholes.
5	<ul style="list-style-type: none"> ○ Liquids to be handled with care • Stripper • Solvent • Hydrazine • Fuming sulfuric acid 	<ul style="list-style-type: none"> ● Some strippers may cause cracks on the bellows or piping (PFA) at an early stage. Contact us for a warranty period applied for such liquids. ● An explosion-proof construction are required for solvents. Contact Iwaki for details.

Installation

#	Points to be checked	Description
6	○ Always stop the pump while releasing discharge pressure.	⚠CAUTION Stopping the pump without releasing discharge pressure may deform the bellows.
7	○ Do not leave the pump unused for a long period with a liquid in the pump.	⚠CAUTION Some chemicals may penetrate component parts and attack electrodes or other parts. In order to prevent this, release corrosive gas in the air chamber. (Run the pump for ten minutes every day for replacing air.)
8	○ Do not narrow an air exhaust port or exhaust line.	⚠CAUTION If air exhaust lines are extended from the five-port solenoid valve and are too narrow, smooth air transfer is disturbed, and the bellows may deform.
9	○ Do not supply air to both right & left air supply ports at once when pump is stop.	⚠CAUTION <ul style="list-style-type: none"> ● If air is supplied to both right and left air chambers when the pump has stopped, the bellows may deform. ● Some double solenoid valves supply air both air chambers at once. Do not use this type of double solenoid valve.
10	○ Do not close a discharge line as pump stops.	⚠CAUTION <ul style="list-style-type: none"> ● Do not close the discharge liquid line by an air operated valve as the pump stops. Otherwise an impact pressure may deform the bellows or a connecting plate. ● Always open an air operated valve except drainage.

■ Other precautions

1. Pump surface temperature

⚠WARNING

Wear protective gloves. Pump and piping surface temperature reaches liquid temperature.

Model	Stroke rate	Liquid temperature	Cylinder surface temperature	Room temperature
FF-10H	120spm	180°C	75°C	30°C
FF-20H	120spm			
FF-40H	80spm			

2. Noise from pump

Exhaust noise accompanies pump operation. Apply a protective measure as necessary. <JIS.Z.8735>

Model	Supply air pressure	Stroke rate	Noise level
FF-10H	0.196MPa	120spm	65dB(A)
FF-20H		120spm	
FF-40H		80spm	

Installation

2. Installation/Piping/Wiring

Stop working upon perceiving any danger or abnormal sign.

⚠ WARNING

Be sure to turn off the power before starting any maintenance/repair work. Make sure no one turns on the power while working on the pump, otherwise it may result in a serious accident. If your work field is noisy or dark, let other people know about the situation by displaying a notice such as "POWER OFF(Maintenance)" near the power switch.

Electrical wiring works must be done by well-trained operator(s). We are not responsible for any injury or damage due to improper works.

■ Installation

1. Pump installation position

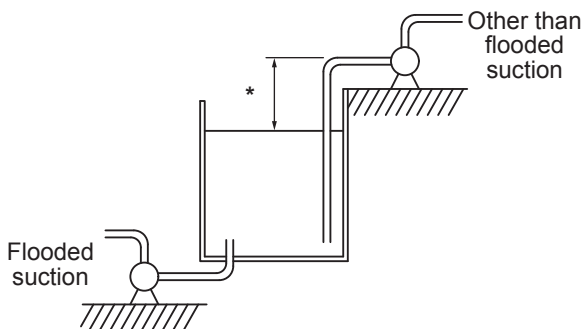

● Under flooded suction

Place the pump as close to the supply tank as possible.

⚠ CAUTION

Flooded suction is recommended for hot liquid transfer or for looped system.

● Other than flooded suction

Observe the maximum suction lift. Place the pump as close to the supply tank as possible.

*Suction lift

FF-10H: 1m

FF-20H & -40H: 2m

⚠ CAUTION

The suction lifts are based on pumping ambient clean water at the maximum stroke rate and vary with liquid characteristics, liquid temperature or suction line length. Contact us for detailed information.

2. Installation surface

Select a flat and solid foundation (such as a chassis) free from vibration.

3. Inlet/Outlet direction

Position the pump with a vertical outlet and horizontal inlet. Secure the pump with anchor bolts.

4. Re-tightening of cylinder head fixing bolts (for securing air tight)

Retighten the stud bolts on the cylinder head by the following tightening torque.

FF-10H : 5.4N•m

FF-20H & -40H : 6.4N•m

⚠ CAUTION

Be sure to tighten the cylinder head fixing bolts by the tightening torque before operation. If the pump runs with a loose cylinder head, liquid/air may leak.

Installation

■ Pipework

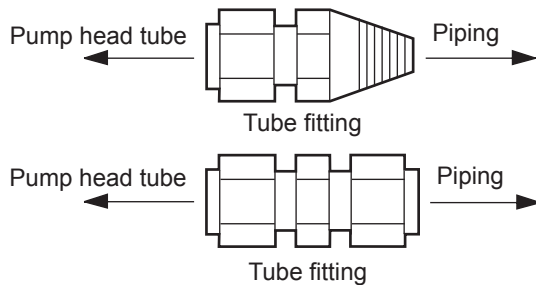

1. Inlet & outlet bore and materials

PFA tubes are originally equipped to inlet & outlet of the pump. Tube bore is as follows.

FF-10H.....1/2"

FF-20H.....3/4"

FF-40H.....1"(ø25×ø22)

*Select an appropriate tube fitting size (See diagram above.). Both discharge and suction lines shall have a larger bore than the pump outlet & inlet.

2. Air blow or flush a tube to get rid of foreign matters prior to connecting it with the pump.

3. Do not force the pump into tubing. Use tube supports to reduce the vibration and thermal stress to the pump.

4. Be sure to secure each connection to prevent leakage and air suction.

5. General joints can be used, however, no leakage is allowed under hot liquid transfer or heat cycle.

■ Suction line

1. Have the suction line wide and shortest in flooded suction. In other than flooded suction, observe the maximum suction lift.

*The suction lift differs with the liquid's characteristics, temperature, and suction pipe length. For detailed information, contact Iwaki.

2. Install a filter or strainer at the suction pipe end to prevent particles from entering the bellows. The filter or strainer should not increase piping resistance too much.

⚠ CAUTION

If wafer fragments enter the pump, they may get stuck in the bellows and eventually cause failure. If it clogs the valves, the discharge volume may reduce and the pumping operation may become unbalanced.

3. When installing a valve on the suction line, select a valve with an orifice whose diameter is equal to or larger than pipe bore. A valve with a small orifice may increase the pipe resistance or easily be clogged with crystals. Always open valves during operation.

⚠ CAUTION

Operating the pump with a suction side valve close, negative pressure increases in the bellows and deforms the bellows inwardly.

Installation

■ Discharge line

1. *The pipe resistance increases as a discharge line becomes longer or the number of bends increases. In order to decrease pipe resistance, install a dampener to minimize pulsation. When sending a liquid up via a riser pipe, install a check valve.*
2. *When installing a valve in a discharge line, select a valve with an orifice whose diameter is equal to or larger than pipe bore. A valve with a small orifice may increase the pipe resistance or easily be clogged with crystals. Always open valves during operation. Do not close the valve until the discharge pressure reaches "0" after the pump is stopped.*

⚠ CAUTION

Do not close a discharge valve right after stopping the pump. Impact pressure may deform the bellows.

3. *Check a filtering area, filtering performance and effects on the flow before selecting a cycle filter. Desired flow may not be obtained if selection is wrong.*

⚠ CAUTION

Wet the filter before use. A desired flow may not be obtained if the filter is not wet enough. Filter dries up if it is unused for a long period. Read the instruction manual of the filter for details.

4. *Install a filter or strainer in a discharge line not to release foreign matters or wafer fragments. The filter or strainer should not increase piping resistance too much.*
5. *Be sure to release discharge pressure when stopping the pump by the filter and the air vent valve or a return circuit.*

⚠ CAUTION

Stopping the pump without releasing discharge pressure may deform the bellows.

Installation

■ Degassing

Gas bubbles are generated when a strong acid is fed into the reaction tank or liquid is transferred through a narrow tube. If such bubbles enter the bellows, the pump runs dry, increasing stroke rate or disturbing liquid transfer. Take a proper step for degassing.

The stroke rate increment is a sign of dry running. In this case take the following corrective actions.

Plan A (Install a baffle to remove gas bubbles)

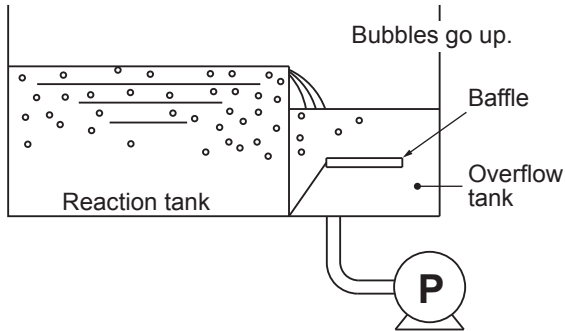

In flooded suction

Install a baffle in a overflow tank to separate air from the liquid.

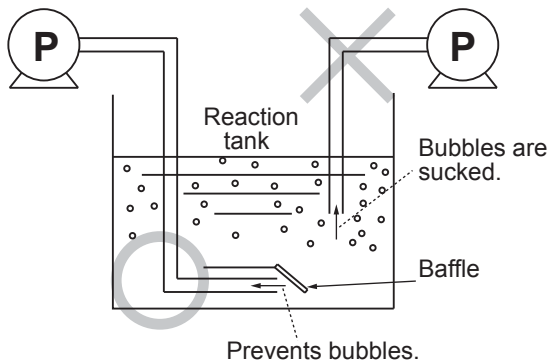

Other than flooded suction

Install a baffle near the bottom of the reaction tank. And then place the end of suction line under the baffle to suck liquid only.

Plan B (Install an automatic valve)

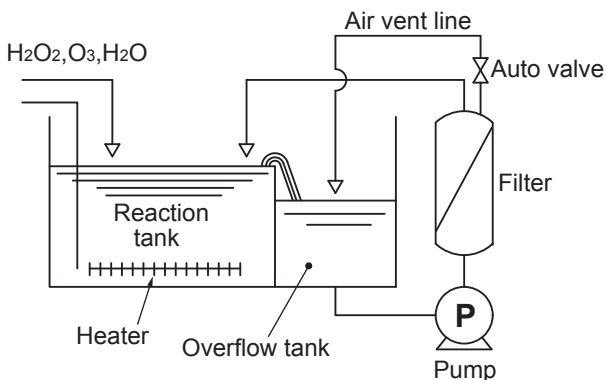

Periodic degassing

Program an automatic valve to open periodically regardless of dry running. For example, the valve opens for ten seconds every two minutes.

NOTE 1: Some filtering area are too tight to release air. Select a suitable filter.

NOTE 2: Program an open time according to the system performance.

Pinpoint degassing

If gas bubbles occur only when H_2O_2 is fed in the reaction tank, install an air detector at the pump inlet and set the auto valve to open timely.

Installing an air detector at the pump outlet, air ingress can also be detected at a bellows rupture.

Installation

■ Air piping

⚠ CAUTION

- Supply air should be free from moisture and dust. If the supply air is contaminated with water, oil or dust, the pump may fail in starting. If water enters the air chambers, the electrodes may detect it and sounds an alarm.
- Long and narrow air supply tubing prevents...
 - a. Air from being expelled from the air chamber. This may deform the bellows inwardly.
 - b. Stroke rate from increasing. This may reduce flow.

Air piping diagram

Complete air piping in accordance with the diagram below.

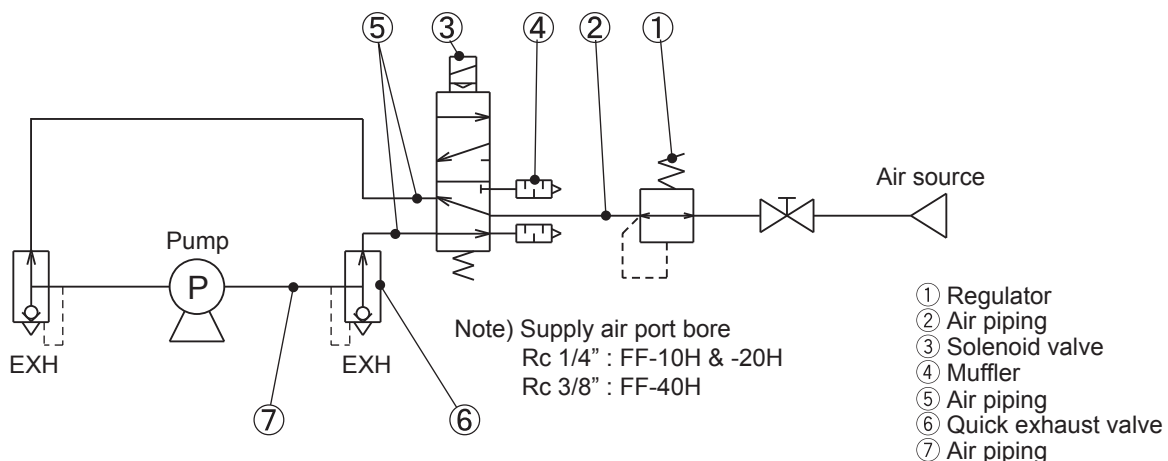

1. Regulator

Select one regulator per pump in accordance with the air consumption of the pump (Pressure drop should be at or below 20kPa.).

⚠ CAUTION

Observe the maximum supply air pressure 0.196MPa. Otherwise the bellows may deform. Stop the pump before setting the supply air pressure. Install one regulator per pump.

⚠ CAUTION

Just one regulator can not cover two or more solenoid valves because the valve located farthest from the regulator may not work properly due to a low pressure.

2. Air tube bore

Air tube bore between the regulator and the solenoid valve shall be equal to or larger than 6.5mm for the FF-10H & -20H (10mm or larger for the FF-40H).

Installation

3. Solenoid valve

Select a five-port solenoid valve whose effective cross-sectional area is equal to or more than 25mm². The bore of supply air ports shall be equal to or larger than Rc1/4" for the FF-10H & -20H (Rc3/8" or larger for the FF-40H).

⚠ CAUTION

Use a 2-position double-solenoid valve. Using a 3-position type, the bellows may be deformed because some 3-position solenoid valves pressurize/depressurize both the air chambers when the pump has stopped.

4. Muffler

Mufflers should be installed on the exhaust ports of the solenoid valve or quick exhaust valves. Select a muffler whose effective cross-sectional area is equal to or more than 20mm² for the FF-10H & 20H (43mm² or more for the FF-40H.)

5. Air piping between the pump and the solenoid valve

Satisfy the specified requirement below.

Air piping length

	FF-10H & -20H	FF-40H
1m or less	ID 6.5mm or more	ID 10mm or more
1-5m	ID 9mm or more, otherwise use the quick exhaust valve	ID 12mm or more, otherwise use the quick exhaust valve
5m or more	Contact us	

⚠ CAUTION

Right and left air pipe length should be equal. Extremely different length can make pulsation big and can affect flow.

Installation

6. Quick exhaust valve

The air from the pump is exhausted via the exhaust ports of the solenoid valve (Fig. 1).

Some chemical generates permeable gas. The gas may mix with the exhaust air and may corrode the solenoid valve. In this case install quick exhaust valves between the pump and the solenoid valve so that air will be exhausted through the quick exhaust valves (A slight amount of air will be exhausted through the electromagnetic valve.). Quick exhaust valves are recommended to be placed within 1m from the pump (Fig. 2).

Air flow

Fig.1 Air flow without quick exhaust valves

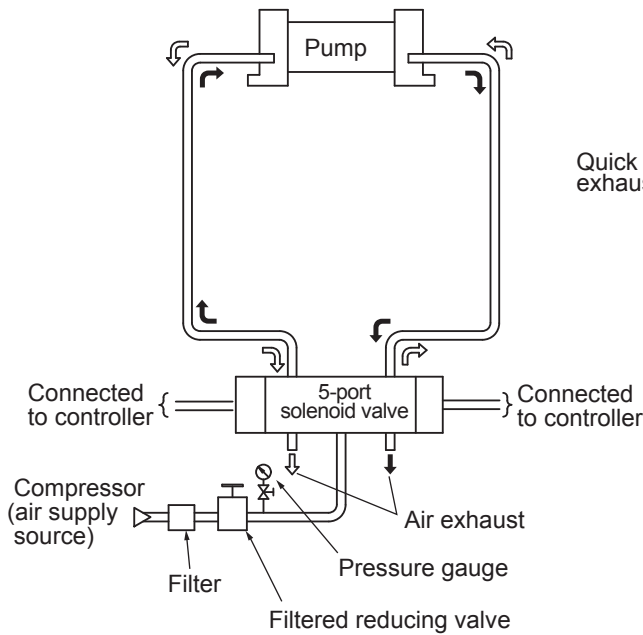
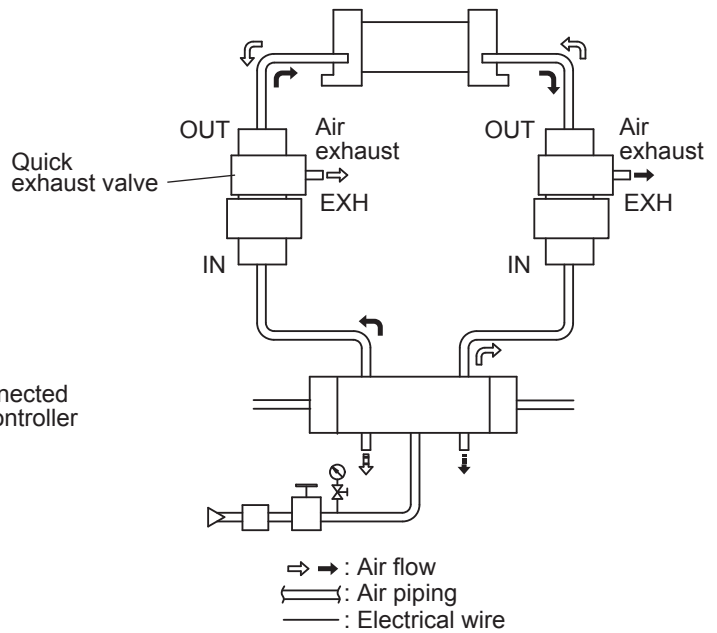

Fig. 2 Air flow with quick exhaust valves



2-position 5 port single solenoid valve

*The quick exhaust valve has IN, OUT and EXH ports (stamped on the valve.). See Fig.2.

7. Air piping between the quick exhaust valves and the pump

Satisfy the requirement below.

Air piping length

	FF-10H & -20H	FF-40H
Pipe length	1m or less	
Pipe bore	6.5mm or more	10mm or more

Installation

■ Precautions for air piping

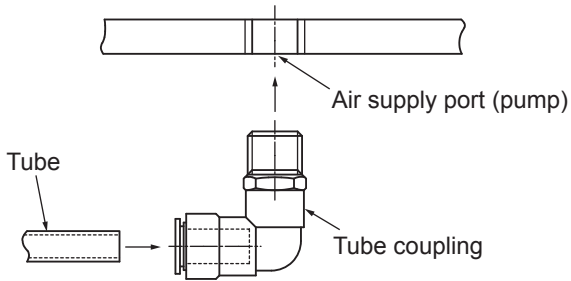

1. Supply air port bore

Supply air port bore on the pump

FF-10H & -20H : Rc 1/4"

FF-40H : Rc3/8"

*Air tube bore between the regulator and the solenoid valve shall be equal to or larger than 6.5mm for the FF-10H & -20H (10mm or larger for the FF-40H).

2. Pressure reducing valve

Fluctuation of supply air pressure affects the stroke rate and the flow rate. Install a pressure reducing valve to maintain the supply air pressure constant.

3. Safety valve

Install a safety valve not to exceed the maximum supply air pressure 0.196MPa.

4. The exhaust air from the mufflers and solenoid valve

Release the exhaust air into the open air.

⚠ CAUTION

Narrowing the air exhaust port makes air less likely to be expelled. As a result the bellows may deform inwardly. Select necessary air devices with reference to the air piping diagram on page 19.

5. Reduction of exhaust noise

To reduce exhaust noise, release the exhaust air through the duct of the plant facility to the air, or attach silencers to exhaust ports.

6. When installing two or more pumps

The air consumption increases as the number of pumps increases. Optimize the air compressor capacity and pipe bore taking account of the total number of pumps.

Installation

■ Effective cross-sectional area

1. Effective cross-sectional area

In the field of pneumatic devices, the term “Effective cross-sectional area” is used to indicate actual air flow. When air is sent through a pipe, air cannot flow fully for the actual cross-sectional area due to piping resistance. The air flow increases as effective cross-sectional area becomes larger.

*For detail of effective cross-sectional area at each pneumatic device, see the catalogue issued by each manufacturers.

2. Composite effective cross-sectional area

Pneumatic devices are connected in series with the pump. It is necessary to determine the composite effective cross-sectional area of the entire system by calculating each device.

Composite effective cross-sectional area is calculated from the following formula.

$$\frac{1}{S^2} = \frac{1}{S1^2} + \frac{1}{S2^2} + \dots + \frac{1}{Sn^2}$$

S : Composite effective cross-sectional area (mm²)

Sn: Effective cross-sectional area of each pneumatic device (mm²)

See the catalogues issued by device/pipe manufacturers for each effective cross-sectional area.

Effective cross-sectional area on the exhaust side (OUT→EXH)

Quick exhaust valve (QEV-8V): 33mm².

Required composite effective cross-sectional area

FF-10H & -20H =13.2mm²

FF-40H =19.5mm²

Check that the composite effective cross-sectional area of the actual air piping meets the above requirement.

■ Preventive measures against condensation

If condensation is likely to occur in the pipe between the pump and solenoid valve, take the following preventive measures.

- Reduce supply air pressure as much as possible (Reduce stroke rate.).
- Arrange a heater (or heat insulator) system over the piping.
- Feed the heated and compressed air to the pump. Observe the temperature limits of piping, joints, solenoid valve and other component parts.

Installation

■ Wiring diagram

The following shows a wiring diagram for the AC-1 (the FD, SC or FDC-1) controller and the five-port solenoid valve. Refer to instruction manuals of each controller for further information.

Wiring with the AC-1 controller

Be sure to turn off the controller. Then conduct wiring according to the following diagram and an instruction attached to the controller. The following diagram shows the use of the AC-1 controller.

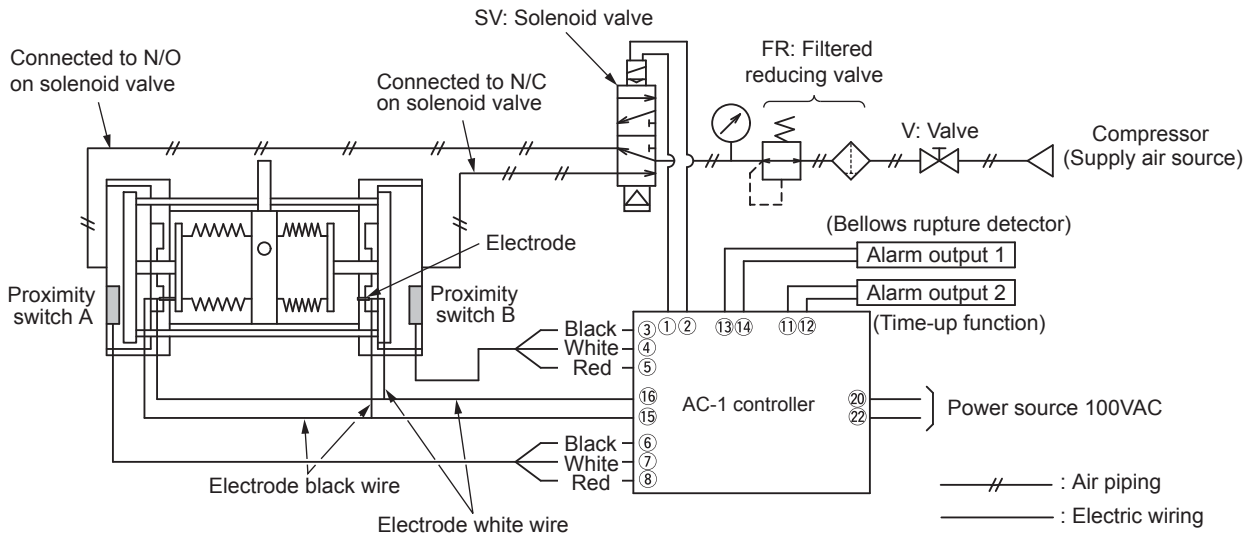

1. Wiring for proximity switch

⚠ CAUTION

The proximity switches has three wires: black, white and red. Improper wiring may break a controller. Carry out wiring work properly.

- ▶ Proximity switch A: Connect wires (black, white and red) with terminals ⑥⑦⑧.
- ▶ Proximity switch B: Connect wires (black, white and red) with terminals ③④⑤.

*The wire colour of proximity switches differs with pump model. See below for compatibility.

FA & FH	FF-H & FF	Remarks
Blue	→ Black	0V
Black	→ White	Output
Brown	→ Red	Power voltage (10-30VDC)

⚠ WARNING

Standard proximity switches cannot be used when a flammable liquid such as solvent is used. The proximity switches must be in explosion-proof specifications. Contact us or your nearest dealer.

Installation

2. Wiring for electrode

Connect white and black wires (approximately 1.8m), which are extended from both the right and left sides of the pump with controller terminals ⑮ and ⑯.

- ▶ Join right and left white wires and connect it with controller terminal ⑯.
- ▶ Join right and left black wires and connect it with controller terminal ⑮.
- Never connect the white and black wires. They will be conducted.

⚠ WARNING

The use of an electrode is prohibited when a flammable liquid such as solvent is pumped. A spark in a solvent may cause a fire.

3. Wiring for five-port solenoid valve

Connect the cord of the solenoid valve with the controller terminal ①(+) and ②(-).

Note that the surge killer type does have a polarity while normal solenoid valves are not polarity sensitive.

⚠ CAUTION

Pay attention to the +/– polarity. Improper polarity may result in breakage. Generally, the five-port solenoid valves are not polarity sensitive, however, some solenoid valve may have polarity.

*The 'normally open' should be connected to the proximity switch A and 'normally closed' should be connected to the proximity switch B. The pump does not run with totally opposite connection. To run the pump in this state, interchange the air piping of the solenoid valve or interchange wiring between proximity switches A and B.

4. Wiring for alarm 1

Diaphragm rupture alarm shall be connected to the controller terminal ⑬ and ⑭.

- If liquid leaks from the bellows and electrodes are conducted, the controller stops the five-port solenoid valve and the pump. At this time the red LED lights on the controller and the alarm signal is outputted.

5. Wiring for alarm 2

Time up alarm shall be connected to the controller terminal ⑪ and ⑫.

- If the operation is disturbed or stroke rate is reduced, the yellow LED lights on the controller. Alarm signal is also outputted.

Installation

■ Wiring with the SC controller

The diagram below shows the wiring diagram with the SC controller. See the instruction manual of the SC controller for detail.

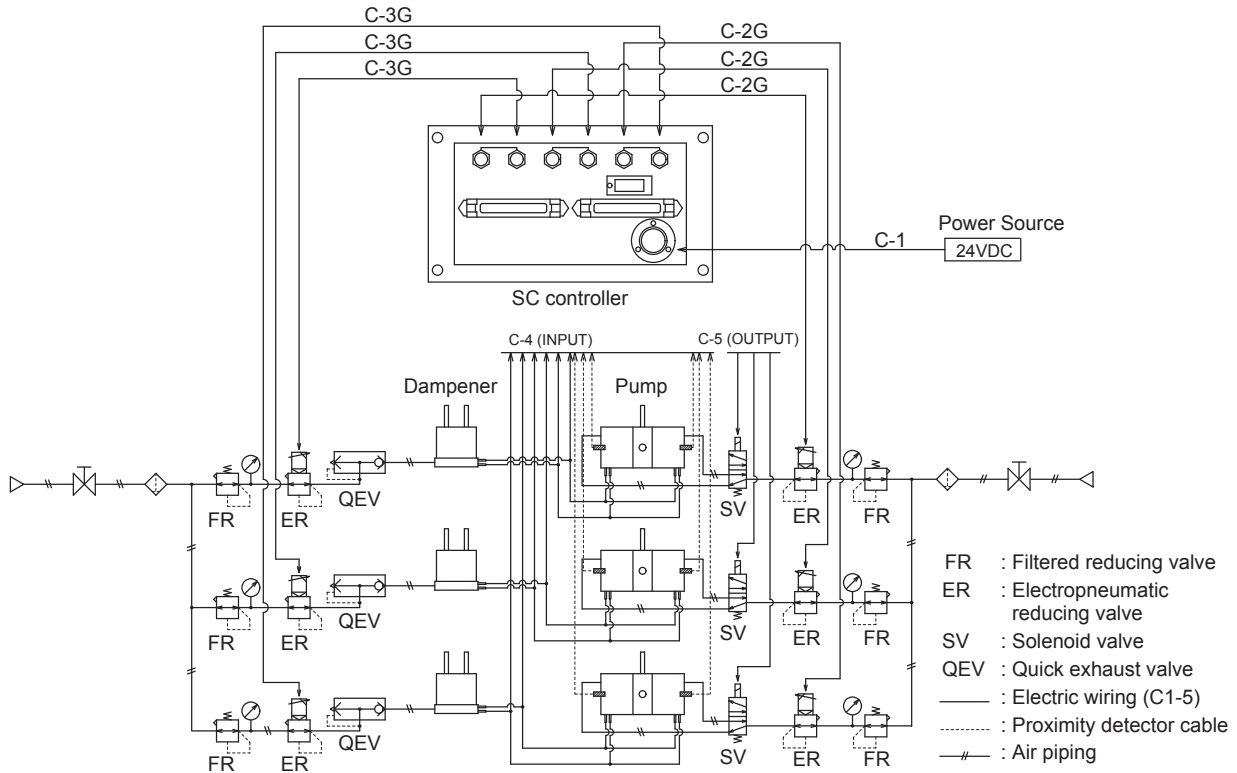

■ Wiring instructions

1. Other cords

Proximity switch cord (1m) and electrode cord (1.8m) are equipped in advance to the pump, however, other necessary cords below need to be prepared separately.

Cord	Power
Controller power cord	115V 0.24A or more
Connecting wire between the pump and the 5-port solenoid valve	24V 0.24A or more

2. Extension of electrode wire

Keep the resistance of the electrode + the attached lead wire (about 1.8m in length) at or below 5kΩ.

Otherwise, the bellows rupture alarm does not function to stop the pump when the resistance is beyond the detection range.

3. Wiring of proximity switch

Do not band the proximity switch wires with the power line or another high-voltage cable in the same duct or cable tube. Otherwise the switch may malfunction. The cross-section of the switch wire should be 0.3mm² or more when wire length is within 30m. The resistance should be 100Ω/km or less when wire length is more than 30m.

Operation

<i>1. Before operation</i>	<i>28</i>
<i>2. Operation.....</i>	<i>28</i>
<i>3. Check items.....</i>	<i>29</i>

Operation

1. Before operation

Carry out the following preparatory steps when starting the pump for the first time after installation or after a long period of storage.

1. Check that the electric wiring is correct (Wiring for the proximity switches, electrodes and solenoid valve).

⚠ CAUTION

Improper wiring leads to proximity switch failure.

2. Check that the air piping are correct. Check for a loose joint.

3. Check that the pump is fixed in place.

4. Check that the liquid piping are correct. Check for a loose joint.

5. Check the suction and discharge valves are fully opened.

6. Check that the tank is filled with liquid.

⚠ CAUTION

Before operation in your system, conduct a trial run with pure water (or chemical liquid) to flush out particles or to measure metal ion level.

7. Check that the filter is wet enough.

⚠ CAUTION

See the instruction manual of the filter for detail.

2. Operation

Flush your system and piping by conducting a trial run.

The operation with the AC-1 controller is described below. See each instruction manual for the FD, SC and FDC-1 controllers.

■ Starting the pump

1. *Supply air to the pump*

Set the regulator to a specified supply air pressure. Then open a supply air valve.

⚠ CAUTION

Observe the maximum supply air pressure 0.196MPa. Otherwise the bellows may deform. Stop the pump before setting the supply air pressure.

⚠ CAUTION

Set an opening of a supply air vent in order for the pump not to run over the maximum stroke rate (120spm: FF-10H & -20H, 80spm: FF-40H) under dry running.

2. *Switch on the controller.*

The pump starts to run. The blue LED blinks on the controller.

Operation

■ Stopping the pump

1. Switch off the controller. The pump stops running and the LED goes out.
2. Make sure a discharge line is open when stopping the pump.

⚠ CAUTION

Do not close a discharge valve as stopping the pump.

3. Arrange your system to release discharge pressure as the pump stops.

■ Flow rate adjustment

The flow rate can be adjusted by adjusting the supply air valve.

3. Check items

Pay attention to the following points during operation.

Upon detecting any abnormal sign, stop the pump and see "Troubleshooting".

#	Check items	Remarks
1	Pump stroke rate	Observe the maximum stroke rate (120spm: FF-10H & -20H, 80 spm: FF-40H)
2	Supply air pressure	Observe the maximum supply air pressure 0.196MPa
3	Supply air rate	
4	Joints on air/liquid piping	
5	Cleanness of supply air	

Maintenance

<i>1. Troubleshooting</i>	<i>31</i>
<i>2. Maintenance & Inspection</i>	<i>33</i>
<i>3. Wear parts</i>	<i>34</i>

Maintenance

1. Troubleshooting

Trouble	Causes	Measures	Points to be checked
The pump does not run.	Switchover failure of solenoid valve.	<ul style="list-style-type: none"> Inspect, repair or replace as necessary. 	<ul style="list-style-type: none"> Use a quick exhaust valve if corrosive gas affects the solenoid valve.
	Improper wiring or disconnection of proximity switches	<ul style="list-style-type: none"> Inspect/correct wiring. Replace as necessary* 	<ul style="list-style-type: none"> Check if wires are arranged as described in the manual. Check air piping and wiring.
	Bellows rupture. (Alarm output)	<ul style="list-style-type: none"> Replace the bellows* 	<ul style="list-style-type: none"> Check supply air pressure. Check stroke rate. Check liquid temperature. Check if discharge pressure is released when the pump stops. Check if air pipe is too narrow/long. Check if suction line is too narrow.
	Rising discharge pressure	<ul style="list-style-type: none"> Check or replace the filter as necessary. 	<ul style="list-style-type: none"> Check filter for clogging and air elimination. Check if filter is wet enough.
		<ul style="list-style-type: none"> Discharge line is closed. 	<ul style="list-style-type: none"> Open the discharge line.
	Supply air pressure or air volume is too low.	<ul style="list-style-type: none"> Reset the system. 	<ul style="list-style-type: none"> Observe the minimum operation pressure of the solenoid valve. Secure proper air pipe bore and air flow taking account of the number of pumps installed.
Electrode malfunction	<ul style="list-style-type: none"> Keep the pump and supply air dry. 	<ul style="list-style-type: none"> Do not wet the pump. Always keep the supply air dry. 	
The pump runs with no discharge.	Valve is clogged with foreign matters.	<ul style="list-style-type: none"> Clean or replace the pump* 	<ul style="list-style-type: none"> Install a guard filter in a suction line. Check if a valve is blocked with crystal.
		<ul style="list-style-type: none"> A suction line is closed. 	<ul style="list-style-type: none"> Open the suction line.
	Worn valve and valve seat	<ul style="list-style-type: none"> Clean or replace the pump* 	<ul style="list-style-type: none"> Install a guard filter in a suction line. Check if a valve is blocked with crystal.

* means work by Iwaki.

Maintenance

Trouble	Causes	Measures	Points to be checked
Discharge volume is reduced.	Supply air pressure or air volume is reduced.	<ul style="list-style-type: none"> ● Readjust the air flow. 	<ul style="list-style-type: none"> ○ Secure proper air pipe bore and air flow taking account of the number of pumps installed.
	Discharge pressure increment	<ul style="list-style-type: none"> ● Review discharge conditions. 	<ul style="list-style-type: none"> ○ Check filter for clogging. ○ Check the filter for air elimination. ○ Check if discharge line is open.
	Worn valve or valve seat. Stuck valve with foreign matter.	<ul style="list-style-type: none"> ● Check, clean or replace pump head* 	<ul style="list-style-type: none"> ○ Install a guard filter in a suction line.
	Insufficient NPSHa (Net positive suction head available)	<ul style="list-style-type: none"> ● Review suction conditions. 	<ul style="list-style-type: none"> ○ Check if suction pipe is too narrow or long.
Liquid leaks.	Stud bolts are loose.	<ul style="list-style-type: none"> ● Tighten stud bolts. 	<ul style="list-style-type: none"> ○ Tighten stud bolts by rated torque. See next page.
	Bellows rupture	<ul style="list-style-type: none"> ● Check or replace bellows as necessary* 	<ul style="list-style-type: none"> ○ Check supply air pressure. ○ Check stroke rate. ○ Check liquid temperature. ○ Check if discharge pressure is released when the pump stops. ○ Check if air pipe is narrow/long. ○ Check if suction line is too narrow.
Excessive air consumption.	Worn shaft packing	<ul style="list-style-type: none"> ● Replace the packing* 	
Stroke rate reduction	Stud bolt is loose.	<ul style="list-style-type: none"> ● Retighten stud bolts. 	<ul style="list-style-type: none"> ○ Tighten stud bolts with rated torque. See next page.
Unbalanced pump operation	Worn valve or valve seat	<ul style="list-style-type: none"> ● Check, clean or replace the pump* 	
	Solenoid valve malfunction	<ul style="list-style-type: none"> ● Inspect, repair or replace the solenoid valve. 	<ul style="list-style-type: none"> ○ Observe the minimum operation pressure of the solenoid valve.
Excessive vibration or noise	Poor pump fixation.	<ul style="list-style-type: none"> ● Tighten anchor bolts. 	
	Stroke rate is too high.	<ul style="list-style-type: none"> ● Observe the maximum stroke rate. 	<ul style="list-style-type: none"> ○ Reduce supply air pressure or air flow.
Foreign matters from the pump outlet	Chemical crystal, wafer fragments or pump valve fragments (Due to life end.)	<ul style="list-style-type: none"> ● Check, repair or replace the pump as necessary* 	<ul style="list-style-type: none"> ○ Do not send a liquid that crystallizes by nature. ○ Install a filter or strainer in a suction line. ○ Install a filter or strainer in a discharge line.

* means work by Iwaki.

Maintenance

2. Maintenance & Inspection

WARNING

- **Wear protectors**
Always wear protective clothing (protective goggles, cap, mask, etc.) during maintenance and inspection work.
- **Release pressure out of piping**
Residual pressure in the piping may splash liquid and cause an unexpected accident. Release the residual pressure before work.
- **Power OFF**
Be sure to turn off the power before starting a maintenance/repair work. Make sure no one turns on the power while working on the pump, otherwise it may result in a serious accident. Let other people know about the situation by displaying a notice such as "POWER OFF(Maintenance)" by the power switch.

■ Periodic inspection

1. *Check stroke rate has not reduced (At least once a month)*
Stroke rate reduces as air leaks. The wear of shaft packing is a cause of air leak. Replace the shaft packing as necessary.
*Shaft packing replacement shall be conducted by Iwaki.
2. *Check for air and liquid leak (At least once a month)*
If air or liquid leak is detected from the pump, release discharge pressure and supply air pressure, and leave the pump until it cools down to ambient. Then retighten cylinder head fixing bolts by the following torque.
FF-10H: 5.4N•m
FF-20H & -40H: 6.4N•m
3. *Valve assemblies and bellows (At least once a month)*
Valve assemblies and bellows are wear parts and need to be replaced by their estimated life span or when their performance deteriorates. (Life span at each wear part differs with a liquid handled and operating condition.)
*Check valve and bellows replacement shall be conducted by Iwaki.
4. *Pump operation after a long period of suspension*
Supply the air to the pump (approx. 0.196MPa) and confirm there is no air leakage from the outlet before operation.

Maintenance

3. Wear parts

The wear parts shown below should be replaced when it reaches the estimated life end or when performance deteriorates remarkably, whichever comes fast. Contact us.

FF-10H & -20H

No.	Part names	Q'ty	Estimated life
1,2,3,4,5,28	Pump head bellows unit	1	One year (in continuous operation)
12	Shaft packing	2	

NOTE1: The estimated life span varies with operating condition and is not warranted.

NOTE2: Q'ty shows the number of parts.

FF-40H

No.	Part names	Q'ty	Estimated life
1,2,3,4,5,28	Pump head bellows unit	1	One year (in continuous operation)
12	Shaft packing	2	

NOTE1: The estimated life span varies with operating condition and is not warranted.

NOTE2: Q'ty shows the number of parts.



IWAKI CO.,LTD. 6-6 Kanda-Sudacho 2-chome Chiyoda-ku Tokyo 101-8558 Japan
 TEL:(81)3 3254 2935 FAX:3 3252 8892(<http://www.iwakipumps.jp>)

Australia	IWAKI Pumps Australia Pty. Ltd.	TEL:(61)2 9899 2411	FAX: 2 9899 2421	Korea	IWAKI Korea Co.,Ltd.	TEL:(82)2 2630 4800	FAX: 2 2630 4801
Austria	IWAKI (Austria) GmbH	TEL:(43)2 236 33469	FAX: 2 236 33469	Malaysia	IWAKIm Sdn. Bhd.	TEL:(60)3 7803 8807	FAX: 3 7803 4800
Belgium	IWAKI Belgium n.v.	TEL:(32)1 367 0200	FAX: 1 367 2030	Norway	IWAKI Norge AS	TEL:(47)66 81 1660	FAX: 66 81 16 61
China	IWAKI Pumps (Shanghai) Co., Ltd.	TEL:(86)21 6272 7502	FAX: 21 6272 6929	Philippines	IWAKI Chemical Pumps Philippines, Inc.	TEL:(63)2 888 0245	FAX: 2 843 3096
China	IWAKI Pumps (Guandong) Co., Ltd.	TEL:(86)750 3866228	FAX: 750 3866278	Singapore	IWAKI Singapore Pte. Ltd.	TEL:(65)6316 2028	FAX: 6316 3221
China	GFTZ IWAKI Engineering & Trading (Guangzhou)	TEL:(86)20 8435 0603	FAX: 20 8435 9181	Spain	IWAKI Iberica Pumps, S.A.	TEL:(34)943 630030	FAX: 943 628799
China	GFTZ IWAKI Engineering & Trading (Beijing)	TEL:(86)10 6442 7713	FAX: 10 6442 7712	Sweden	IWAKI Sverige AB	TEL:(46)8 511 72900	FAX: 8 511 72922
Denmark	IWAKI Nordic A/S	TEL:(45)48 24 2345	FAX: 48 24 2346	Switzerland	IWAKI (Schweiz) AG	TEL:(41)26 674 9300	FAX: 26 674 9302
Finland	IWAKI Suomi Oy	TEL:(358)9 2745810	FAX: 9 2742715	Taiwan	IWAKI Pumps Taiwan Co., Ltd.	TEL:(886)2 8227 6900	FAX: 2 8227 6818
France	IWAKI France S.A.	TEL:(33)1 69 63 3370	FAX: 1 64 49 9273	Taiwan	IWAKI Pumps Taiwan (Hsin-chu) Co., Ltd.	TEL:(886)3 573 5797	FAX: (886)3 573 5798
Germany	IWAKI EUROPE GmbH	TEL:(49)2154 9254 0	FAX: 2154 9254 48	Thailand	IWAKI (Thailand) Co.,Ltd.	TEL:(66)2 322 2471	FAX: 2 322 2477
Holland	IWAKI Holland B.V.	TEL:(31)297 241121	FAX: 297 273902	U.K.	IWAKI PUMPS (UK) LTD.	TEL:(44)1743 231363	FAX: 1743 366507
Hong Kong	IWAKI Pumps Co., Ltd.	TEL:(852)2 607 1168	FAX: 2 607 1000	U.S.A.	IWAKI America Incorporated	TEL:(1)508 429 1440	FAX: 508 429 1386
Indonesia	IWAKI Singapore (Indonesia Branch)	TEL:(62)21 690 6606	FAX: 21 690 6612	Vietnam	IWAKI Pumps Vietnam Joint Venture Co.,Ltd.	TEL:(84)613 933456	FAX: 613 933399
Italy	IWAKI Italia S.R.L.	TEL:(39)02 990 3931	FAX: 02 990 42888				