

**IWAKI**  
**Magnetic Drive Gear Pump**  
**MDG-R15 (built-in type)**  
**Instruction Manual**

 Read this manual before use of product

Thank you for having selected IWAKI's magnetic drive gear pump model MDG-R15. This instruction manual deals with the correct handling and operation of the pump. You are requested to read this manual prior to installing and using the pump to ensure safe and long life of the pump. The content of this manual may be changed without notice.



## Contents

Safety Instructions .....	1, 2
Outline of Product	
1.Unpacking and inspection .....	3
2.Operating Principle .....	3
3.Model identification .....	4
4.Specification .....	4
5.Dimension .....	5
6.Main parts and label .....	5
7.Performance curves.....	6
Installation	
1.Before use of product .....	7
2.Precautions on operation .....	7, 8
3.Installation, piping and wiring .....	9 ~ 11
Operation	
1.Operation .....	12
2.Stopping .....	12
Maintenance	
1.Troubleshooting .....	13
2.Maintenance and Inspection .....	14
3.Spare parts .....	14
4.Disassembling and assembling .....	15 ~ 18
5.Construction and parts names .....	19



# Important Instruction

## For the Safe and Correct Handling of the Pump

- "Safety Instruction" section deals with important details about handling of the product. Before use, read this section carefully for the prevention of personal injury or property damage.
- Observe the instructions accompanied with "WARNING" or "CAUTION" in this manual. These instructions are very important for protecting pump users from dangerous situations.
- The symbols on this instruction manual have the following meanings:

 <b>WARNING</b>	<b>Nonobservance or misapplication of the contents of "Warning" section could lead to a serious accident which may result in death.</b>
 <b>CAUTION</b>	<b>Nonobservance or misapplication of the contents of "Caution" section could lead to personal injury or property damage.</b>

## Types of Symbols

	Indicates a prohibited action or procedure. Inside or near this circle, a concrete and practical image of the activity to be avoided is depicted.
	Indicates an important action or procedure which must be performed or carried out without fail. Failure to follow the instructions herein can lead to malfunction or damage to the pump.
	Explosion Protection - This symbol identifies information about avoiding explosions in potentially explosive atmospheres in accordance with EC Directive 94/9/EC (ATEX).

## Export Restrictions

Technical information contained in this instruction manual might be treated as controlled technology in your countries, due to agreements in international regime for export control. Please be reminded that export license/permission could be required when this manual is provided, due to export control regulations of your country.

# Safety Instruction

## **Warning**

- **Turn off the power supply.**

Working without disconnecting the power supply may cause an electrical shock. Before engaging upon any working procedures involving the pump, make sure to turn the power supply switch off and to stop the pump and other related devices.



- **Terminate operation.**

When you detect or become aware of a dangerous sign or abnormal condition during operation, terminate the operation immediately and start it from the beginning again.



- **For specified application only.**

The use of a pump in an application other than those clearly specified may result in injury or damage to the pump. Use the pump strictly in accordance with the pump specifications and application range.



Prohibited

- **No remodeling.**

Never remodel a pump. Otherwise, a serious accident may result. Iwaki will not be responsible for any accident or damage of any kind which is caused by the user remodeling the pump without first obtaining permission or instructions from Iwaki.



No Remodeling

- **Wear protectors.**

If you touch or come in contact with any type of hazardous chemical liquid, you may be harmed. Wear protective gear (protective mask, gloves, etc.) during the works for the pump.



Wear protective gear

## **Caution**

- **Qualified operators only.**

The pump operator and pump operation supervisor must not allow any operators who have little or no knowledge of the pump to run or operate the pump. Pump operators must have enough knowledge of the pump and its operation.



Prohibited

- **Specified power only.**

Do not operate the pump on voltage which is not specified on the nameplate. Failure to do so may result in damage or fire. Only the specified power level is to be applied.



Prohibited

- **Do not wet or dampen.**

If the motor or wiring cable becomes wet or dampened with the operating liquid by mistake, this may result in a fire or cause an electrical shock. Install the motor and wiring cable in positions which are not likely to become wet or dampened with any liquid.



Prohibited

- **Ventilate.**

Poisoning may result during an operation which involves toxic or odorous liquid. Ventilate the operating site sufficiently.



Caution

- **Spill-out accident.**

Protective measures should be taken against any accidental spill-out or leakage of the operating liquid as a result of unexpected damage on the pump or the related piping.



Caution

- **Operating site must be free of water and humidity.**

The pump is not designed to be water-proof or dust-proof. The use of the pump in places where water splashes or humidity is high may result in an electrical shock or short circuit.



Prohibited

# Safety Instruction

## Caution

- **Do not damage power cable.**

Do not scratch, damage, process, or pull the power cable forcibly. An extra load onto the cable, such as heating the cable or placing something heavy on the cable, may damage the cable and finally cause a fire or an electrical shock.



Caution

- **Do not cover the motor.**

Running a covered motor may accumulate heat inside the motor and cause a fire or a mechanical failure. Ventilate the motor sufficiently.



- **Arrange grounding.**

Do not operate the pump without connecting the grounding wire. Otherwise, an electrical shock may result. Make sure the grounding wire is connected with the grounding terminal. 



Grounding

- **Install an earth leakage breaker.**

The operation of a pump without using an earth leakage breaker may cause an electrical shock. Please install a leakage breaker.



Electrical Shock

- **Power cable cannot be replaced.**

Never use a damaged or affected power cable. Otherwise, a fire or an electrical shock may result. Handle the power cable carefully, as it cannot be replaced by a new cable. (The complete motor must be replaced in that circumstance.)



Caution

- **Do not use damaged pump.**

Use of damaged pump may cause short-circuit and electrical shock. Never use damaged pump.



Prohibited

## Caution

- **Limited operating site and storage.**

Do not install or store the pump in the following places:

\* Places where a flammable gas or material is used or stored.

\* Places where the ambient temperature is extremely high (40°C or higher) or extremely low (0°C or lower).



Prohibited

- **Do not drain the liquid in the site.**

The liquid discharged out of the pump, including a hazardous chemical liquid, must be drained into a special container. Never drain such liquid directly onto the floor in or near the operation site.



Prohibited

- **Disposal of used pump.**

Disposal of used or damaged pumps must be done in accordance with the relevant local laws and regulations. (Consult a licensed industrial waste products disposing company.)



- **Replacement of parts.**

Replacement of parts must be done according to this instruction manual. Do not disassemble pump exceeding the extent shown on this manual.



- **Countermeasure for static electricity.**

When low electric conductivity liquid such as ultra-pure water and flour inactive liquid (e.g. Fluorinert™) are handled, the static electricity may be generated in pump, which may cause static discharge and break down of pump. Take countermeasure to avoid and remove static electricity.



# Outline of Product

## 1. Unpacking and inspection

After unpacking the product, check to see:

- 1) If model name, discharge capacity, discharge pressure, voltage etc. shown on the nameplate are those that you order.
- 2) If the product is not damaged or its bolts and nuts are not loosened during transportation.

Iwaki Magnet Gear Pump		
MODEL		
MAX. CAPACITY	ℓ/min	
MAX. PRESSURE	MPa	
SINGLE PHASE INDUCTION MOTOR CAPACITOR-RUN		
POLES	SPEED	rpm
VOLTAGE	V RATING	CONT.
CURRENT	A CAPACITOR	μF
OUTPUT	W	INSULATION CLASS E
POWER CONSUMPTION	W	
FREQUENCY	Hz	INDOOR
<b>DO NOT RUN PUMP DRY</b>		
MFG.No.		
<b>IWAKI CO.,LTD.</b> TOKYO JAPAN		

If you find any abnormality, please contact your dealer.

## 2. Operating principle

IWAKI magnetic drive gear pump MDG-R15 consists of a pair of gears driven by magnetic coupling and the casing which contains the gears. ( Fig. A)

The liquid which gets into from suction side enters into gear grooves and is transferred to discharge side by the rotation of gears. (Fig. B and C)

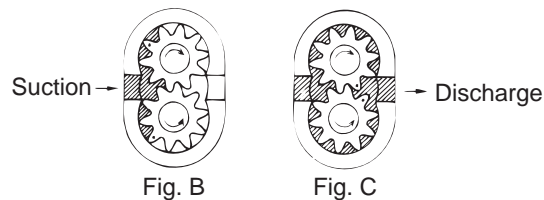
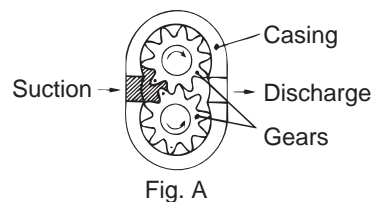

→ : Direction of liquid flow

# Outline of Product

## 3. Model identification

MDG - R 15 T 220  
 (1) (2) (3) (4)

(1) Pump type

(2) Pump size

15 : 5.5 ml/revolution

(3) Allowable liquid temperature and material of gear/bearing

T : 0 – 45 deg. C PTFE gear, GFRPTFE bearing

P : 0 – 45 deg. C PEEK gear, (CF +PTFE) PPS bearing

K : 0 – 95 deg. C PTFE gear, GFRPTFE bearing

C : 0 – 95 deg. C PEEK gear, (CF + PTFE) PPS bearing

(4) Motor voltage

115 : 115V single phase

220 : 220 – 240V single phase

## 4. Specification

50/60Hz

Model	Pump bore	Max. flow L/min.	Max. disch. press. MPa	Max. vacuum KPa (abs)	Rated speed rpm	Motor specification			Mass kg
						Rated voltage	Rated ampere	Type	
MDG-R15T115	Rc3/8	14/17	0.3	5.33	2800/ 3300	AC 115	2.3/2.8	Single phase induction motor capacitor run	7.8
MDG-R15K115		12.5/15		8.00					
MDG-R15P115		14/17		5.33					
MDG-R15C115		12.5/15		8.00					
MDG-R15T220		14/17		5.33		AC 220-240	1.4/1.5		
MDG-R15K220		12.5/15		8.00					
MDG-R15P220		14/17		5.33					
MDG-R15C220		12.5/15		8.00					

Note 1. Performance shown above is based on pumping clear water at 25 deg.

C. (discharge capacity changes according to the pumped liquid temperature. Ask IWAKI for details.

2. Allowable ambient temperature is 0 – 40 deg. C.

3. Allowable viscosity of pumped liquid is up to 30 mPa·s.

4. Maximum operating noise is 65dB or below.

(1m away from the front of a pump, A scale)

# Outline of Product

## 5. Dimension

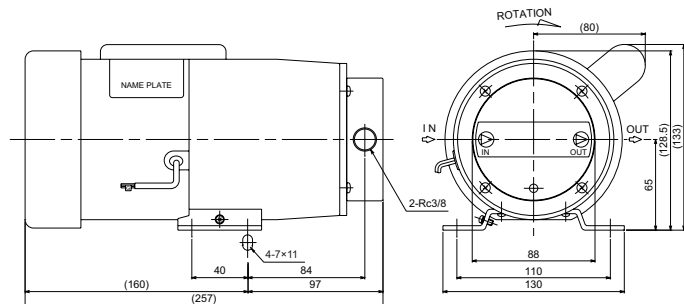

MDG-R15 ( ) 115

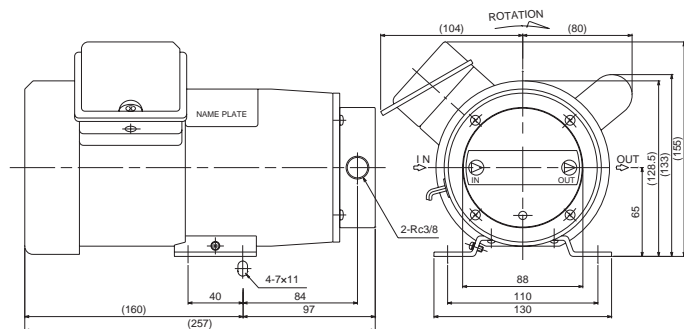

MDG-R15 ( ) 220

## 6. Main parts and label

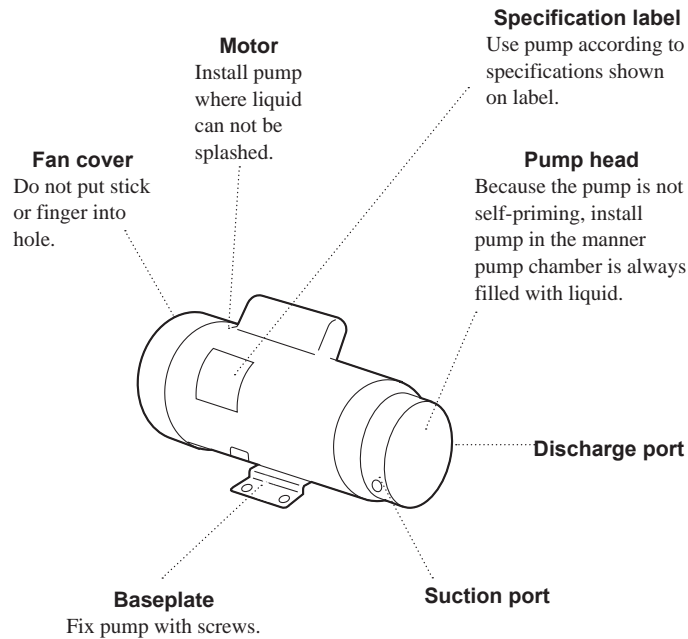

# Outline of Product

## 7. Performance curves

MDG-R15T115  
MDG-R15T220  
MDG-R15P115  
MDG-R15P220

MDG-R15K115  
MDG-R15K220  
MDG-R15C115  
MDG-R15C220

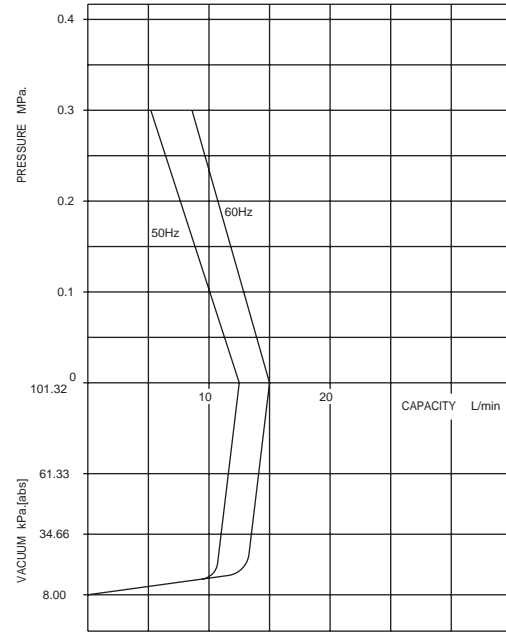
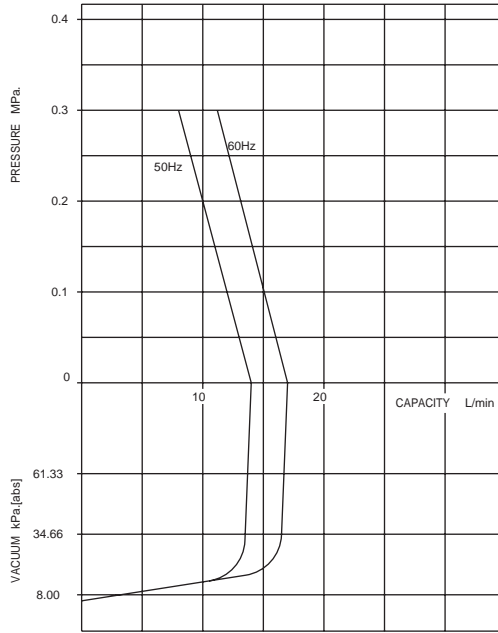



# Installation

## 1. Before use of product



### Caution

#### Do not run pump dry

Dry running of pump causes quick wearing of gear and bearing. 

#### Do not close discharge and suction valves

If pump is operated with suction and discharge valves closed, temperature inside pump excessively increases in a short time resulting in pump failure or burning. Operate pump with valves opened. 

#### Do not install pump outdoor

Motor is not water-proof construction. If liquid is splashed on motor, it may cause fire or damage of motor. Do not install pump outdoor.

#### Keep fire away from pump

Do not put dangerous or flammable substance around pump.

#### Damaged pump

Do not use damaged pump to avoid short-circuit or electrical shock.

## 2. Precautions on operation

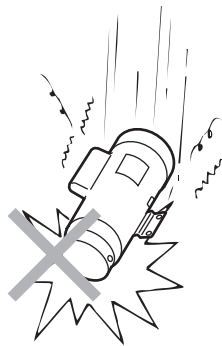

### (1) Handle pump carefully

Strong impacts on pump caused by dropping it on floor or so may result in damage or faulty performance of pump.

### (2) Do not touch pump

Pump/motor is very hot during operation or just after it is stopped. Do not touch it with bare hand.

### (3) Prime pump

Pump is not self-priming. Prime pump with liquid before starting pump.

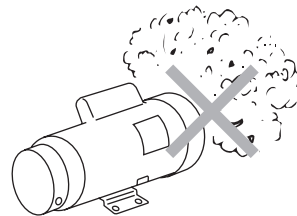

### (4) Keep pump away from dusty atmosphere

Do not use pump at dusty atmosphere and take measures for dust not to adhere to motor.

# Installation

## (5) Install earth leakage breaker

Install earth leakage breaker to avoid accident such as electrical shock etc.

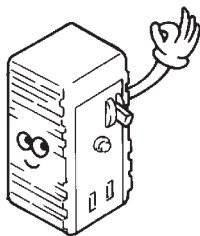

## (6) Do not splash liquid on motor.

If motor or wires are wetted by splashed liquid, it may cause fire or electrical shock. Install pump at place where liquid can not be splashed on pump/motor.

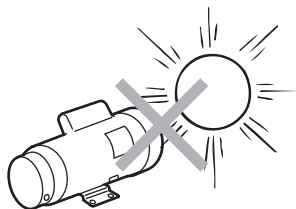

## (7) Place to be installed

Do not install or store pump at following places.

- where exposed to direct sunlight
- where ambient temperature increases to 40 deg. C or more
- where humid and dusty atmosphere
- where ambient temperature becomes 0 deg. C or below.
- where exposed to rain and wind

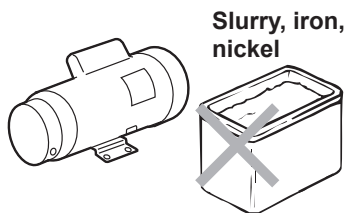

Slurry, iron,  
nickel

## (8) Ground

Connect ground from ground wire (green) for MDG-115R ( ) 115 and from ground terminal of terminal box for MDG-R15 ( ) 220. 

## (9) Prohibited liquids

Following liquids can not be pumped. 

- liquids which contain iron or nickel powder
- liquids which contain slurry
- liquids which are crystallized when stopping
- flammable liquids such as gasoline or kerosene

## (10) Power cord can not be replaced.

Do not use pump of which the power cord is damaged.

## (11) Maintenance and cleaning

Do not use solvents such as benzene, alcohol or thinner to clean pump. Otherwise, paint gets discolored or peeled.

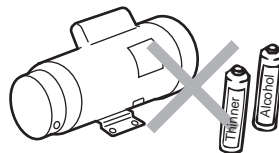

# Installation

## 3. Installation, piping and wiring

### 3-1. Installation

#### 1) Place to be installed

Install the pump at the place where ambient temperature is 40 deg. C or below, relative humidity is 85% or below and where the maintenance and inspection works can be done easily. Do not install pump outdoor.

- #### 2) Install the pump the lower position than liquid level of suction tank (Flooded suction piping). When it is unavoidable that the pump is installed at the place where its suction port is higher than the liquid level of suction tank (Suction lift piping), install the pump referring to the pictures on right. In this case, the pump can not suck up the liquid if the pump chamber is not wet. (MDG-R15K and C types can not be used for suction lift piping.)

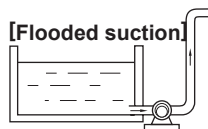

**[Suction lift] In case pump chamber is wet.**

- ① In case of no liquid in suction piping. (Only T and P types are possibly used.)

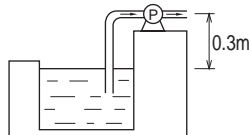

- ② In case liquid is filled in suction piping.

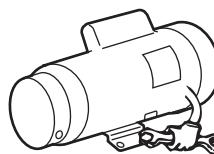
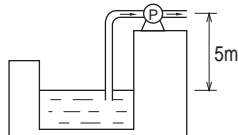

#### 3) Fix baseplate

Fix the baseplate with screws M6. If the noise is large because of resonance of mounting floor, mount the pump via rubber cushion. Mount the pump in horizontal position.

Side view of hose

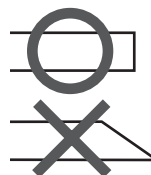

#### 4) Preparation of hose

Before installation works, prepare the hose of which the end is cut as shown on left.

### 3-2. Piping

- #### 1) To minimize the pipe resistance of liquid, use the piping as short and as less bends as possible.

# Installation

- 2) Connect joints to the suction and discharge ports of pump. Apply seal tape so that the air can not be sucked in. Above all improper connection of suction side joint will cause air being sucked resulting in fallen pump performance.
- 3) Use correct size of hose to ensure firm connection. Use the hose of which the material can chemically resist to the pumped liquid. When PVC hose used, use one which can endure the pressure made by the pump.

## Caution

Suction side hose may be collapsed due to vacuum made by pump operation. When hose is used, employ the durable one such as blade hose. Special attention must be paid when pumping high temperature liquid.

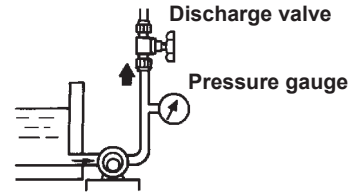
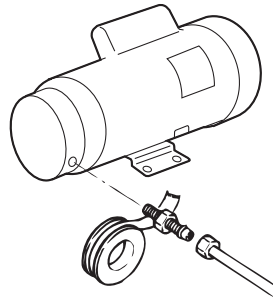

- 4) When you screw the joints in suction and discharge ports, hold the pump head with hand but do not hold the motor. Tightening torque is 15N·m or less.
- 5) If a pressure gauge is installed at discharge piping, you can find the abnormal operation of pump when it happens.
- 6) Periodically check the piping if it is not loosened and tighten it if loosened.



# Installation

## 3-3. Wiring



### Caution

Electrical and wiring works must be done by qualified electrician. Otherwise accident of injury or damage may happen.

- 1) Before wiring is done, check if the main power source is switched off.
- 2) Use the power of pump which is indicated on the nameplate of pump.
- 3) The pump has no ON/OFF switch. The pump starts running as soon as the power cord is connected to the power source.
- 4) Take the ground. 
- 5) In case the earth leakage breaker is installed and when it is operated, reset it after the reason is settled. Switch off the power when you check the reason.

### ■ Rated current, starting current

#### 115V type

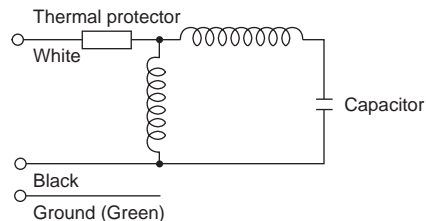

#### 220V type

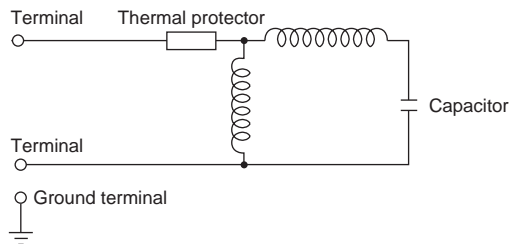

50/60Hz

Model	Voltage (V)	Rated current (A)	Starting current (A)
MDG-R15 ( ) 115	115	2.3/2.8	6.1/5.7
MDG-R15 ( ) 220	220 - 240	1.4/1.5	3.55/3.2

# Operation

## 1. Operation

Operate the pump according to following procedure.



### Caution

Never run pump dry (without liquid) or run pump with suction and/or discharge valve closed. Otherwise, pump is damaged. 

No.	Procedure	Description
1	Check piping, wiring and power voltage.	<ul style="list-style-type: none"> <li>• Check piping, wiring according to items “Piping” and “Wiring” in Installation section.</li> <li>• Check power voltage according to description on nameplate.</li> </ul>
2	Open valves	<ul style="list-style-type: none"> <li>• Fully open the valves on suction and discharge pipings.</li> </ul>
3	Check if liquid is filled in pump chamber.	<ul style="list-style-type: none"> <li>• In case of suction lift application, prime liquid sufficiently.</li> </ul>
4	Switch on power to start	<ul style="list-style-type: none"> <li>• After above procedures, switch on power and check if pump runs normally. If pump does not discharge liquid, stop it immediately and eliminate the cause referring to item “Troubleshooting”.</li> </ul>
5	Operation	<ul style="list-style-type: none"> <li>• Adjust valves gradually to get required flow rate, pressure or vacuum.</li> <li>• Rapid open and close of valves will cause disconnection of magnetic coupling. If this happened, switch off power to stop motor. Magnetic coupling will recover once the motor stops its rotation.</li> <li>• Do not operate pump with discharge and suction side valves fully or almost fully closed. </li> </ul>
6	Precaution during pump operation	<ul style="list-style-type: none"> <li>• Do not get foreign matters into pump. Foreign matter in pump will cause locked gears or abnormal wear of gears.</li> <li>• If earth leakage breaker operates, reset it after the cause is eliminated. Switch off the power and check the reason referring to item “Troubleshooting”.</li> </ul>

## 2. Stopping





No.	Stopping procedure	Description
1	Switch off power. (Check stopping condition)	<ul style="list-style-type: none"> <li>• When power is switched off, check if motor stops smoothly. If motor does not stop smoothly, you should inspect pump.</li> </ul>
2	Close discharge side valve.	<ul style="list-style-type: none"> <li>• Close discharge side valve gradually. Do not close it rapidly.</li> </ul>



### Precautions when pump is not used for a long period

When pump is not used for a long time, remove the liquid inside pump. Run the pump for five minutes once three months to circulate water to prevent rust from motor bearing.

# Maintenance

## 1. Troubleshooting

Trouble	Cause	Countermeasures
Motor stops during operation.	<ul style="list-style-type: none"> <li>• Wrong wiring</li> <li>• Thermal protector operates due to over loaded motor.</li> <li>• Earth leakage breaker operates due to short circuit.</li> </ul>	<ul style="list-style-type: none"> <li>• Check and correct wiring.</li> <li>• Reduce viscosity of liquid or discharge pressure.</li> <li>• Check and repair or replace.</li> </ul>
Pump does not discharge liquid or capacity is low.	<ul style="list-style-type: none"> <li>• No liquid at suction side and pump runs dry. </li> <li>• Air is sucked in from suction side.</li> <li>• Suction side hose is collapsed.</li> <li>• Pressure at suction port is below saturated vapor pressure of pumped liquid.</li> <li>• Viscosity of liquid is too high.</li> <li>• Valve is closed. </li> <li>• Too large pipe resistance.</li> <li>• Worn gear</li> </ul>	<ul style="list-style-type: none"> <li>• Fill liquid in suction tank or open suction side valve.</li> <li>• Check suction side piping and correct it.</li> <li>• Replace hose by stronger one.</li> <li>• Decrease liquid temperature or pipe resistance of suction piping.</li> <li>• Decrease liquid viscosity.</li> <li>• Open valve.</li> <li>• Correct piping.</li> <li>• Replace gear.</li> </ul>
Magnet coupling is disconnected.	<ul style="list-style-type: none"> <li>• No liquid at suction side and pump runs dry. </li> <li>• Gears are locked by their swelling.</li> <li>• Gears are locked by their expansion by heat.</li> <li>• Foreign matters adhere to gears.</li> <li>• Damaged gears.</li> <li>• Magnet capsule touches rear casing.</li> <li>• Valve is fully closed. </li> <li>• Too large pipe resistance.</li> <li>• Wrong pump is used in view of chemical resistibility.</li> </ul>	<ul style="list-style-type: none"> <li>• Fill liquid in suction tank or open suction side valve.</li> <li>• Check chemical resistibility of gears.</li> <li>• Bring down liquid temperature.</li> <li>• Disassemble pump and remove foreign matters.</li> <li>• Replace gears.</li> <li>• Disassemble pump and repair or replace parts.</li> <li>• Open valve.</li> <li>• Correct piping.</li> <li>• Select suitable pump.</li> </ul>

Trouble	Cause	Countermeasures
Motor does not start.	<ul style="list-style-type: none"> <li>• Power is not switched on.</li> <li>• Wrong or disconnected wiring.</li> <li>• Failed motor or its winding is disconnected.</li> <li>• Earth leakage breaker operates due to short circuit.</li> <li>• Earth leakage breaker operates due to lack of power capacity.</li> </ul>	<ul style="list-style-type: none"> <li>• Switch on power.</li> <li>• Check and correct wiring.</li> <li>• Repair or replace motor.</li> <li>• Check and repair or replace.</li> <li>• Employ larger power capacity.</li> </ul>
Abnormal noise or vibration	<ul style="list-style-type: none"> <li>• No liquid at suction side and pump runs dry. </li> <li>• Foreign matters on gears.</li> <li>• Damaged gear.</li> <li>• Magnet capsule touches rear casing.</li> <li>• Worn gear.</li> </ul>	<ul style="list-style-type: none"> <li>• Fill liquid or open valve of suction side.</li> <li>• Disassemble pump and remove foreign matters.</li> <li>• Replace gear.</li> <li>• Disassemble pump and repair or replace parts.</li> <li>• Replace gear.</li> </ul>
Liquid leaks.	<ul style="list-style-type: none"> <li>• Damaged O ring.</li> <li>• Loosened bolts.</li> <li>• Wrong pump is selected in view of chemical resistibility.</li> </ul>	<ul style="list-style-type: none"> <li>• Replace O ring.</li> <li>• Tighten bolts.</li> <li>• Use suitable pump.</li> </ul>
Pump does not self-prime.	<ul style="list-style-type: none"> <li>• No liquid at suction side and pump runs dry. </li> <li>• Air is sucked in from suction side.</li> <li>• Collapsed suction side hose.</li> <li>• Pump inside is dry.</li> <li>• Pressure at suction port is below saturated vapor pressure of pumped liquid.</li> <li>• Worn gear.</li> <li>• Too high suction lift.</li> </ul>	<ul style="list-style-type: none"> <li>• Fill liquid in suction tank or open valve at suction side.</li> <li>• Check suction side piping and correct.</li> <li>• Replace by stronger hose.</li> <li>• Fill liquid from suction or discharge port.</li> <li>• Bring down liquid temperature or pipe resistance.</li> <li>• Replace gear.</li> <li>• Lower suction lift height.</li> </ul>



# Maintenance

## 2. Maintenance and inspection

No.	Check item	Description	Method
1	If pump discharge liquid normally.	<ul style="list-style-type: none"> <li>• If liquid is normally transferred.</li> <li>• If suction and discharge pressure is normal.</li> </ul>	<ul style="list-style-type: none"> <li>• Flow meter or by eye.</li> <li>• Refer to figures shown on name plate.</li> </ul>
2	If sound and vibration are normal.	<ul style="list-style-type: none"> <li>• Abnormal sound or vibration may be generated when pump does not operate normally.</li> <li>• Resonance of base to which pump is mounted may enlarge vibration. In this case, take countermeasure such as rubber cushion etc.</li> </ul>	<ul style="list-style-type: none"> <li>• By eye and year.</li> <li>• By eye and year.</li> </ul>
3	If liquid does not leaks or air does not sucked from pump or piping.	<ul style="list-style-type: none"> <li>• Tighten bolts of the parts from which liquid leaks.</li> <li>• When you see bubbles in discharged liquid, air is sucked in. Check piping and tighten relating bolts.</li> </ul>	<ul style="list-style-type: none"> <li>• By eye.</li> </ul>
4	If pump or motor surface is not extremely hot.	<ul style="list-style-type: none"> <li>• Surface temperature of pump body is same as that of pumped liquid.</li> <li>• Surface temperature of motor is within ambient temperature plus approx. 40 deg. C. You may not touch motor but it is not abnormal if it is within this temperature.</li> </ul>	<ul style="list-style-type: none"> <li>• By touching or thermometer.</li> </ul>

## 3. Spare parts

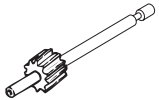
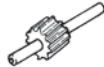
If the pump is continuously operated for a long time, it is needed that the consumable parts are replaced at proper time. It is recommended you always keep the consumable parts shown as bellow.

No. (Note 1)	Parts	Q'ty	Time to be replaced (Note 2)
13	Drive gear 	1	MDG-R15T&K types ... 3,000 hours MDG-R15P&C types ... 5,000 hours
11	Driven gear 	1	
10	Bearing 	6	
3	O ring 	1	To be replaced at the time of maintenance works are done.

Note 1: Number corresponds to that of exploded view and drawing.

2: Time to be replaced is the time that the flow rate goes down by 20% compared to original flow rate when pumping clear water at ambient temperature at pressure of 0.2MPa.



# Maintenance

---

---

## 4. Disassembly and assembly

### 4-1. Disassembly (Parts No. relates to the construction drawing and exploded view.)

- 1) Remove four pan-head screws (15) to remove pump head from motor (1).
- 2) Remove six pan-head screws (16) to remove mounting plate (4), rear casing (6) and O ring (3).
- 3) Loosen hex. socket head screw (5) with hex. wrench (Nominal 2.5) and pull out a magnet capsule (7) from the shaft of drive gear (13). Take care iron powder can not be attracted to the magnet capsule.
- 4) Remove four pan-head screws (17) and disassemble the pump in order of bearing holder (9), gear case (12), two parallel pins (19), drive gear (13) and driven gear (11). Pay attention not to harm the parts when the pump is disassembled.

## 4-2. Replacement of bearings

### 4-2a For models MDG-R15T and K (equipped with GFRPTFE bearings)

- 1) Pull out six bearings(10) which are inserted in pump body (14) and bearing holder (9). Screw M8 bolt by approx. 5mm into worn bearing to pull it out together with bolt.

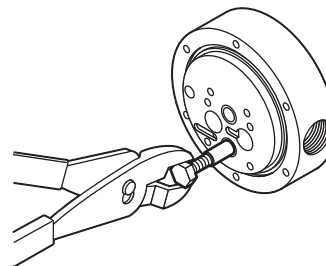

**Pull out bearing from pump body**

- 2) Put the slits of bearing (10) to the direction of line which connects the centers of two bearing holes, and insert it into the bearing hole of pump body (14) and bearing holder (9). End of bearing is located by 0.5mm lower than end surface of pump body (14) and bearing holder (9). Put the bearing carefully into the bearing hole so that it comes in straight along with the bearing hole. Total six bearings are inserted.
- 3) Insert the bearings to both sides of bearing holder (9).

# Maintenance

4) After the six new bearings (10) are inserted, adjust their inner diameter by putting the hand reamer of 7.15mm diameter into the bearings. Prepare two types of hand reamer, that is, the one is standard and another is that of which end is not tapered. First put the standard reamer by turning it by fingers, and then put not tapered one to finish. (If you wish jigs, ask our dealer.)

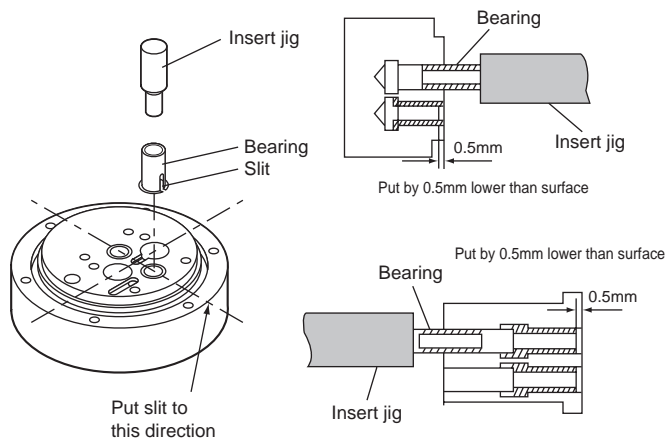

## 4-2b For models of models MDG-R15P and C (equipped with PPS bearings)

1) Pull out two bearings (10) which are inserted into pump body (14). Screw in by 15mm depth a screw (Nominal 8mm dia. x 25mm length) into worn bearing and pull it out together with the screw.

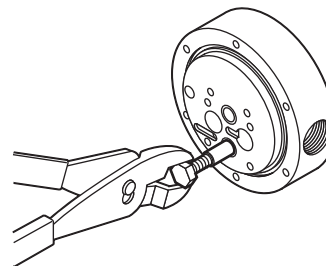

**Pull out bearing from pump body**

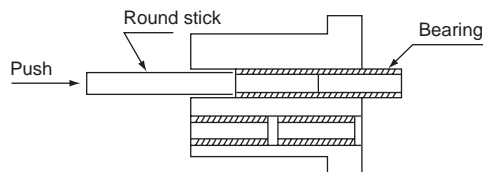

**Pull out bearing from bearing holder**

# Maintenance

- 2) Pull out four bearings (10) which are inserted in bearing holder (9). Fixing the bearing holder (9), push the bearing with a round stick of 9.5mm dia. to push out the worn bearing.
- 3) Insert the bearings (10) into the bearing holes of bearing holder (9) and pump body (14). Put the bearing end by 0.5mm lower than the end of bearing holder (9) and pump body (14). Put the bearing carefully into the bearing hole so that it comes in straight along with the bearing hole. Total six bearings are inserted. (If you wish insert jig, ask your dealer.)

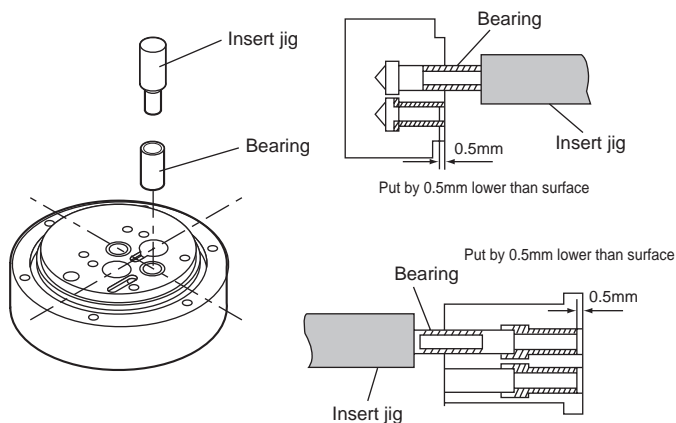

## 4-3. Assembly

- 1) Mount drive gear (13) and driven gear (11) on pump body (14).
- 2) Put two parallel pins (19) on pump body (14). Put the gear case (12) and bearing holder (9) on it and tighten and fix it with four pan-head screws (17) and four spring washers (18). (Tightening torque is 1.76N·m.)
- 3) Insert magnet capsule (7) into shaft of drive gear (13) and fix it with hex. socket head screw (5). Keep 0.5mm distance between magnet capsule (7) and bearing holder (9). (Tightening torque is 3.43N·m.)

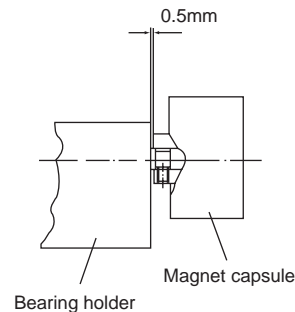

- 4) Insert O ring (3) into pump body (14).

# Maintenance

---

5) Mount rear casing (6) and mounting plate (4) on the pump body so far assembled and fix them with six pan head screw and spring washer (16). Face the chamfered side of mounting plate to the pump body. (Tightening torque is  $1.76\text{N}\cdot\text{m}$ .)

Mount the assembled pump body to motor (1) with four pan-head screws (15). Pay attention for your fingers not to be pinched by strong magnets used. (Tightening torque is  $2.95\text{N}\cdot\text{m}$ .)

## ● Exploded view

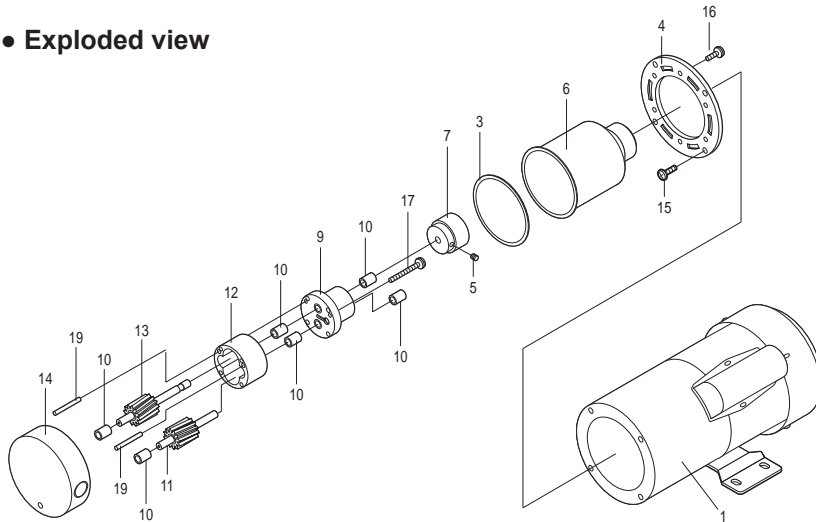

# Maintenance

## 5. Construction and parts names

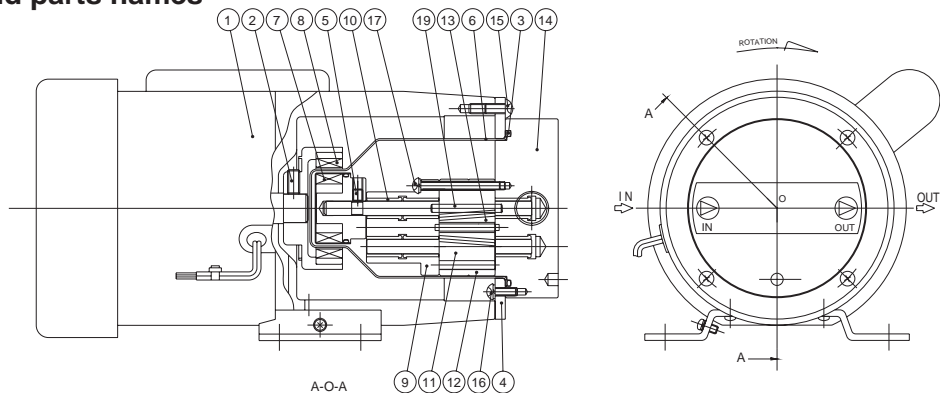

No	Parts name	Mat'l	Q'ty	Remarks	No	Parts name	Mat'l	Q'ty	Remarks
1	Motor		1		11	Driven gear	PTFE, SUS316	1	R15T/K
2	Hex.socket head screw	SNCM	1	M6 × 12	11	Driven gear	PEEK, SUS316	1	R15P/C
3	O ring	FKM	1		12	Gear case	SUS316	1	
4	Mounting plate	Iron	1		13	Drive gear	PTFE, SUS316	1	R15T/K
5	Hex. socket head screw	s.s.	1	M5 × 6	13	Drive gear	PEEK, SUS316	1	R15P/C
6	Rear casing	SUS316	1		14	Pump body	SUS316	1	
7	Magnet capsule	SUS316, FKM, Nd magnet	1		15	Cross rec. head screw	s.s.	4	M5 × 10
8	Drive magnet unit	ADC, Nd magnet	1		16	Cross rec. head screw	s.s.	6	M4 × 12 with s.w.
9	Bearing holder	SUS316	1		17	Cross rec. head screw	s.s.	4	M4 × 45 with S.W.
10	Bearing	GFRPTFE	6	R15T/K	19	Parallel pin	SUS316	2	
10	Bearing	(CF+PTFE) PPS	6	R15P/C					







**IWAKI CO.,LTD.** 6-6 Kanda-Sudacho 2-chome Chiyoda-ku Tokyo 101-8558 Japan  
TEL:(81)3 3254 2935 FAX:3 3252 8892(<http://www.iwakupumps.jp>)

( )Country codes

<b>Australia</b>	<b>IWAKI Pumps Australia Pty. Ltd.</b>	TEL:(61)298992411	FAX:298992421	<b>Italy</b>	<b>IWAKI Europe GmbH, Italy Branch</b>	TEL:(39)0444371115	FAX:0444335350
<b>Austria</b>	<b>IWAKI EUROPE GmbH</b>	TEL:(49)215492540	FAX:2154925448	<b>Korea</b>	<b>IWAKI Korea Co.,Ltd.</b>	TEL:(82)226304800	FAX:226304801
<b>Belgium</b>	<b>IWAKI Belgium n.v.</b>	TEL:(32)13670200	FAX:13672030	<b>Malaysia</b>	<b>IWAKIm Sdn. Bhd.</b>	TEL:(60)378038807	FAX:378034800
<b>China</b>	<b>IWAKI Pumps (Shanghai) Co., Ltd.</b>	TEL:(86)2162727502	FAX:2162726929	<b>Norway</b>	<b>IWAKI Norge AS</b>	TEL:(47)23384900	FAX:23384901
<b>China</b>	<b>IWAKI Pumps (Guangdong) Co., Ltd.</b>	TEL:(86)7503866228	FAX:7503866278	<b>Singapore</b>	<b>IWAKI Singapore Pte. Ltd.</b>	TEL:(65)63162028	FAX:63163221
<b>China</b>	<b>GFTZIWAKI Engineering &amp; Trading (Guangzhou)</b>	TEL:(86)2084350603	FAX:2084359181	<b>Spain</b>	<b>IWAKI Europe GmbH, Spain Branch</b>	TEL:(34)933770198	FAX:934740991
<b>China</b>	<b>GFTZIWAKI Engineering &amp; Trading (Beijing)</b>	TEL:(86)1064427713	FAX:1064427712	<b>Sweden</b>	<b>IWAKI Sverige AB</b>	TEL:(46)851172900	FAX:851172922
<b>Denmark</b>	<b>IWAKI Nordic A/S</b>	TEL:(45)48242345	FAX:48242346	<b>Switzerland</b>	<b>IP Service SA</b>	TEL:(41)266749300	FAX:266749302
<b>Finland</b>	<b>IWAKI Suomi Oy</b>	TEL:(358)92745810	FAX:92742715	<b>Taiwan</b>	<b>IWAKI Pumps Taiwan Co., Ltd.</b>	TEL:(886)282276900	FAX:282276818
<b>France</b>	<b>IWAKI France S.A.</b>	TEL:(33)169633370	FAX:164499273	<b>Taiwan</b>	<b>IWAKI Pumps Taiwan (Hsin-chu) Co., Ltd.</b>	TEL:(886)35735797	FAX:(886)35735798
<b>Germany</b>	<b>IWAKI EUROPE GmbH</b>	TEL:(49)215492540	FAX:2154925448	<b>Thailand</b>	<b>IWAKI (Thailand) Co.,Ltd.</b>	TEL:(66)23222471	FAX:23222477
<b>Holland</b>	<b>IWAKI Europe GmbH, Netherlands Branch</b>	TEL:(31)742420011	FAX:2154925448	<b>U.K.</b>	<b>IWAKI Pumps (UK) LTD.</b>	TEL:(44)1743231363	FAX:1743366507
<b>Hong Kong</b>	<b>IWAKI Pumps Co., Ltd.</b>	TEL:(852)26071168	FAX:26071000	<b>U.S.A.</b>	<b>IWAKI AMERICA Inc.</b>	TEL:(1)5084291440	FAX:5084291386
<b>Indonesia</b>	<b>IWAKI Singapore (Indonesia Branch)</b>	TEL:(62)216906606	FAX:216906612	<b>Vietnam</b>	<b>IWAKI pumps Vietnam Co.,Ltd.</b>	TEL:(84)613933456	FAX:613933399