

Iwaki

Photoresist Dispensing Pump

PDS-H115

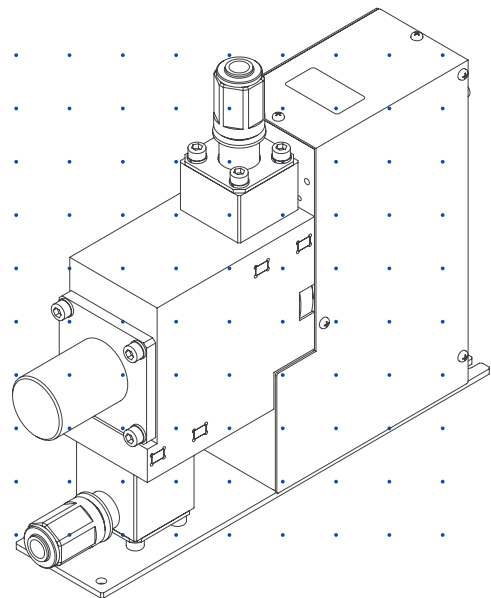

Instruction manual

Thank you for choosing our product.

 Please read through this instruction manual before use.

This instruction manual describes important precautions and instructions for the product. Always keep it on hand for quick reference.

Order confirmation

Open the package and check that the product conforms to your order. If any problem or inconsistency is found, immediately contact your distributor.

a. Check if the delivery is correct.

Check the nameplate to see if the information such as model codes and production number are as ordered.

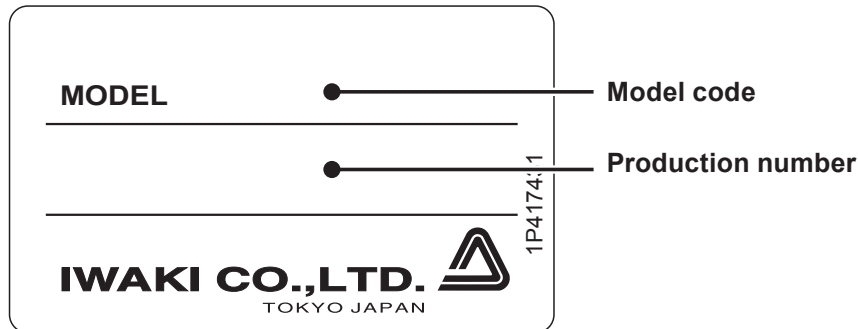

b. Check if the required number of accessories is provided.

<Attached accessories>

- 2-1473562-3 home sensor line connector (one each)
- 2-1473562-4 pressure sensor line connector (one each)
- 1473562-6 motor line connector (one each)
- 3-1473562-8 encoder line connector (one each)
- 5-1473571-3 gender changer for the home sensor line connector (one each)
- 5-1473571-4 gender changer for the pressure sensor line connector (one each)
- 5-1473571-6 gender changer for the motor line connector (one each)
- 5-1473571-8 gender changer for the encoder line connector (one each)

c. Check if the delivery is damaged or deformed.

Check for transit damage and loose bolts.

Contents

Order confirmation	2
Safety instructions.....	5
Warnings	6
Cautions	7
Precautions for use	8
Overview.....	9
Introduction	9
Pump structure & Operating principle	9
Discharge process	9
Suction process	10
Part names	11
Identification codes	12
Installation	13
Before installation.....	13
Installation/Piping/Wiring	14
Installation	14
Piping	14
Wiring	15
Line connectors.....	16
Applicable motor drivers	17
Operation.....	18
Pump setting	18
Pulse input & Motor rotation	18
Number of pulses & Flow volume	18
Number of pulses & Flow rate	18
Return to origin.....	19
Home sensor output is "OFF"	19
Home sensor output is "ON"	19
Operation programming	19
Time based control (when using an Oriental Motor SG9200-2 pulse controller).....	20
Flow based control (when using a pulse signal as a start signal).....	21
Pump operation.....	22

Maintenance..... 23

Troubleshooting	23
Inspection	24
Daily inspection	24
Specification/Outer dimension.....	25
Specification.....	25
Pump.....	25
Stepping motor.....	26
Encoder.....	26
Home sensor.....	26
Pressure sensor.....	26
Outer dimension.....	27
PDS-H115	27

Safety instructions

Read through this section before use. This section describes important information for you to prevent personal injury or property damage.

■ Symbols

In this instruction manual, the degree of risk caused by incorrect use is noted with the following symbols. Please pay attention to the information associated with the symbols.



WARNING

Indicates mishandling could lead to a fatal or serious accident.



CAUTION

Indicates mishandling could lead to personal injury or property damage.

A symbol accompanies each precaution, suggesting the use of "Caution", "Prohibited actions" or specific "Requirement".

Caution marks



Caution



Electrical shock

Prohibited marks



Prohibited



Do not rework or alter



Fire ban

Requirement marks



Requirement



Wear protection

Export Restrictions

Technical information contained in this instruction manual might be treated as controlled technology in your countries, due to agreements in international regime for export control.

Please be reminded that export license/permission could be required when this manual is provided, due to export control regulations of your country.

⚠️ WARNING



Requirement

Turn off power before work

Risk of electrical shock. Be sure to turn off power to stop the pump and related devices before service is performed. Let other people know about the situation by displaying a notice such as "POWER OFF (Maintenance)" near the power switch.



Requirement

Stop operation

If you notice any abnormal or dangerous conditions, suspend operation immediately and inspect/solve problems.



Prohibited

Do not use the pump in any condition other than its intended purpose

The use of the pump in any conditions other than those clearly specified may result in failure or injury. Use this product in specified conditions only.



Do not remodel

Do not modify the pump

Alterations to the pump carries a high degree of risk. It is not the manufacturer's responsibility for any failure or injury resulting from alterations to the pump.



Wear protectors

Wear protective clothing

Always wear protective clothing such as an eye protection, chemical resistant gloves, a mask and a face shield during disassembly, assembly or maintenance work. The specific solution will dictate the degree of protection. Refer to MSDS precautions from the solution supplier.



Requirement

Spill precautions

Ensure protection and containment of solution in the event of plumbing or pump damage (secondary containment).

⚠ CAUTION

Requirement

Qualified personnel only

The pump should be handled or operated by qualified personnel with a full understanding of the pump. Any person not familiar with the product should not take part in the operation or maintenance of the pump.



Prohibition

Use specified power only

Do not apply any power other than that specified on the nameplate. Otherwise, failure or fire may result. Ensure the pump is properly grounded.



Requirement

Ventilation

Fumes or vapours can be hazardous with certain solutions. Ensure proper ventilation at the operation site.



Prohibition

Do not install or store the pump:

- In a flammable atmosphere.
- In a dusty/humid environment.
- In a corrosive atmosphere.



Requirement

Flushing before operation

Flush the inside of the pump and piping with pure water or the liquid to be delivered before the start of operation.



Requirement

Static electricity

When low electric conductivity liquids such as ultra-pure water and fluor inactive liquid (e.g. Fluorinert™) are handled, the static electricity may be generated in the pump and may cause static discharge. Take counter-measures to remove the static electricity.



Requirement

Before returning product

Be sure to drain chemicals and clean the inside of the pump before return so that a harmful chemical does not spill out in transit.



Requirement

Disposal of a used pump

Dispose of any used or damaged pump in accordance with relevant regulations. Consult a licensed industrial waste products disposing company.

Precautions for use

- Electrical work should be performed by a qualified electrician. Otherwise, personal injury or property damage could result.



- Do not install the pump:
 - In a flammable atmosphere.
 - In a dusty/humid place.
 - In a corrosive atmosphere.



- Allow sufficient space around the pump for easy access and maintenance.



- Use care handling the pump. Do not drop. An impact may affect pump performance. Do not use a pump that has been damaged to avoid the risk of electrical damage or shock.

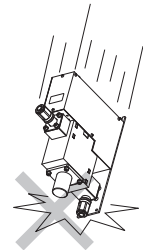

- The pump is not waterproof. Do not operate the pump while wet with solution or water. Failure or injury may result. Immediately dry off the pump if it gets wet.



- Do not close discharge line during operation. Solution may leak or piping may break.



- Solution in the discharge line may be under pressure. Release the pressure from the discharge line before disconnecting plumbing or disassembly of the pump to avoid solution spray.



- Wear protective clothing when handling or working with pumps. Consult solution MSDS for appropriate precautions. Do not come into contact with residual solution.



Overview

Pump working principle, part names and identification codes are described in this section.

Introduction

Pump structure & Operating principle

The rotational motion of the stepping motor is changed to linear motion by the direct drive unit. Liquid is loaded into the pump head and then delivered to a discharge line as the bellows reciprocates.

Principle of operation

- The bellows expands and contracts as the ball screw reciprocates to create volumetric change in the pump chamber.
- Liquid is taken in as the bellows contracts and is pushed out as it expands in sync with the action of the check valves (pump head valves).

■ Discharge process

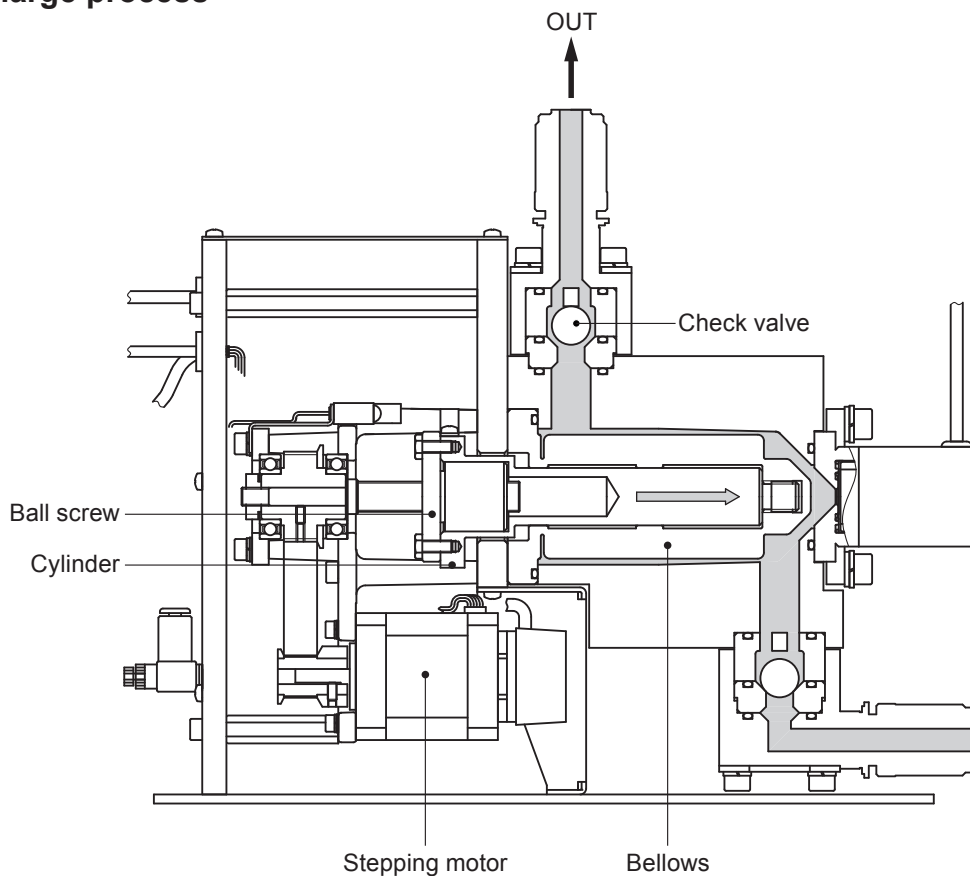

■ Suction process

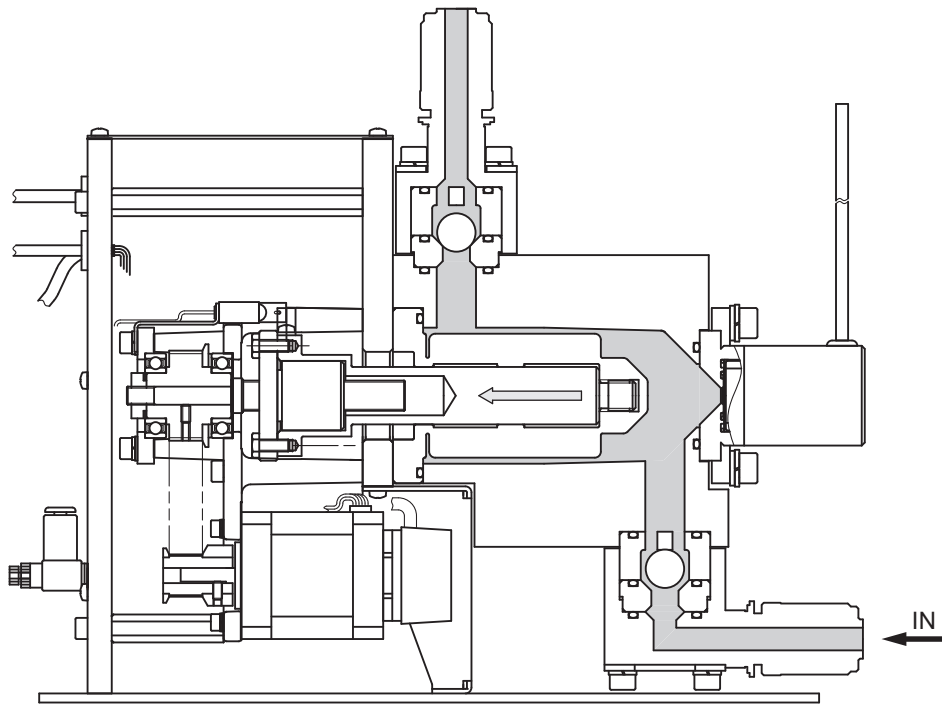

Part names

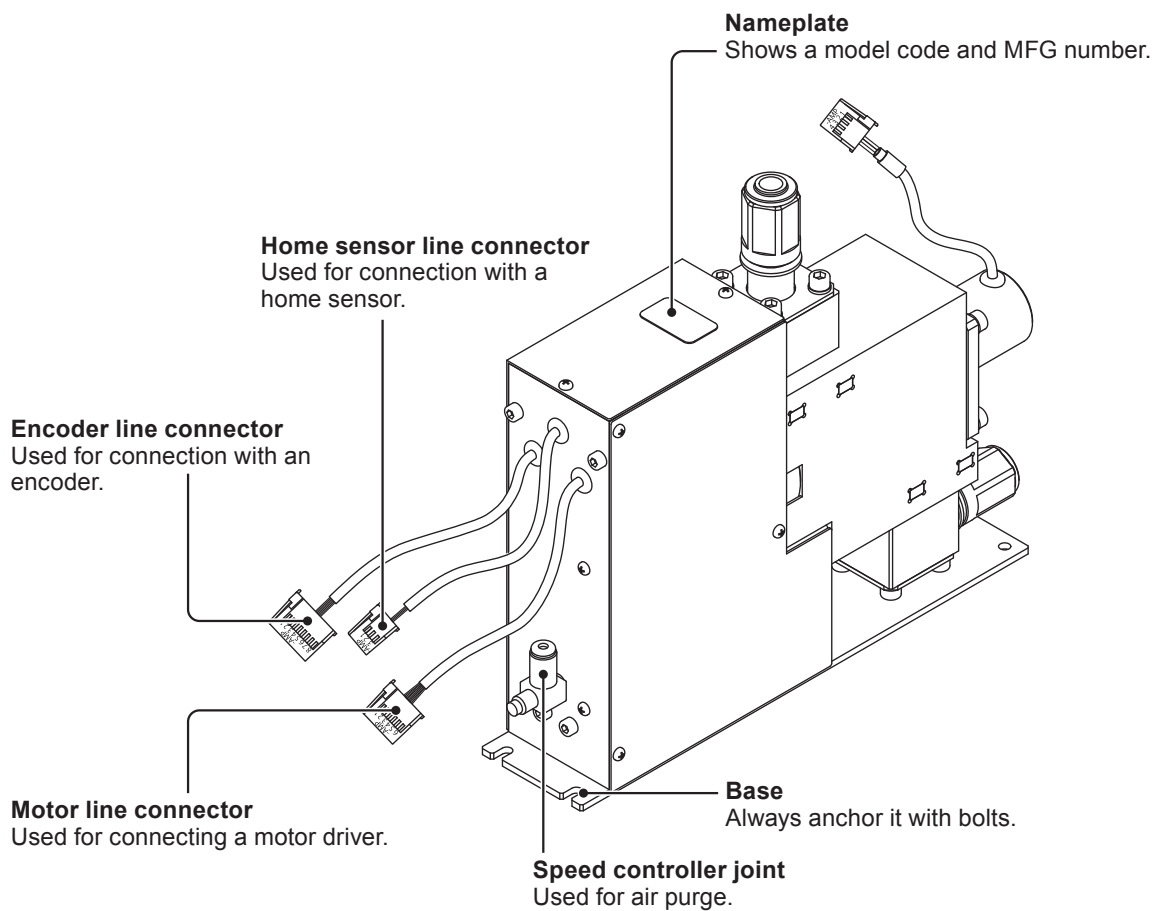
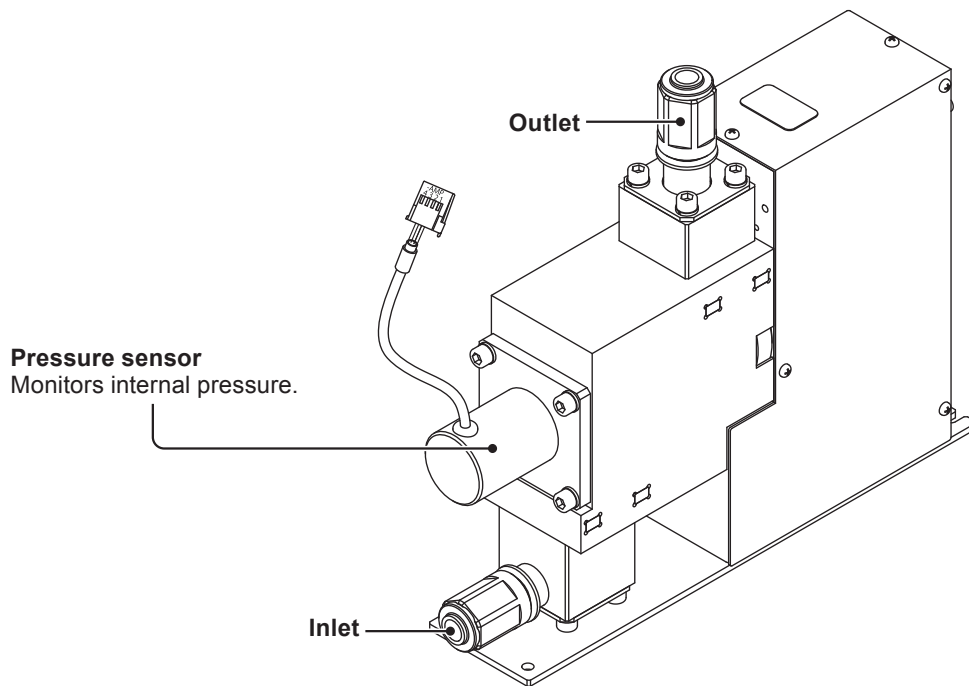

*Do not clean the pressure sensor, speed controller or nameplate with a solvent such as benzene or thinner.

Identification codes

Each code represents the following information.

PDS - H 1 15 - 01

a b c d e

a. Series name

b. Product classification

H: High viscosity type

c. Product category

1: Pump

d. Bellows size

15: 15 type bellows

e. Special version

No code: Standard

01: Custom design (coded in ascending order)

Installation

This section describes the installation of the pump, piping and wiring. Read through this section before work.

! Points to be observed

Observe the following points when installing the pump:

- Be sure to turn off power to stop the pump and related devices before service is performed.
- Be careful for the power not to be turned on while service is performed.
- If you notice any abnormal or dangerous conditions, suspend operation immediately and inspect/solve problems.
- Do not install the pump in a flammable atmosphere.

Observe the following points during wiring work:

- Electrical work should be performed by a qualified electrician. Always observe applicable codes or regulations.
- Do not perform wiring work while the power is on. Otherwise, an electrical shock or short circuit may result. Be sure to turn off power before wiring work.
- Be careful for the power not to be turned on during work.

Before installation

A driver in a user's PLC and other related devices are necessary for operation. Purchase these devices including a motor driver separately as needed. The following diagram is a general system example. Configure your system in accordance with an actual service condition.

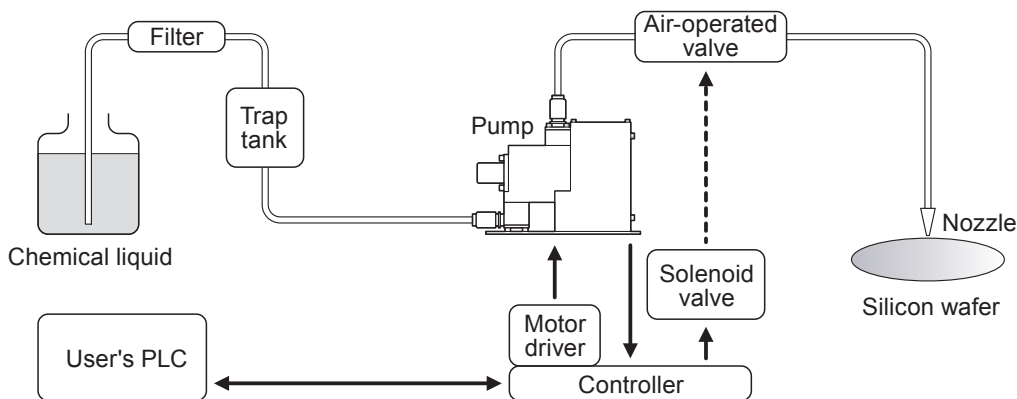

Installation/Piping/Wiring

NOTE

Do not hold the pump head to lift the pump unit up, or the pump head may deform and a leak may result.

Installation

Observe the following points during installation.

● Installation location

Mount the pump indoors. Allow sufficient space around the pump for easy access and maintenance.

● Mounting position

- Install the pump as close to a supply tank as possible in a flooded suction system.
- Make sure the discharge-line end-nozzle is positioned higher than a chemical liquid level.

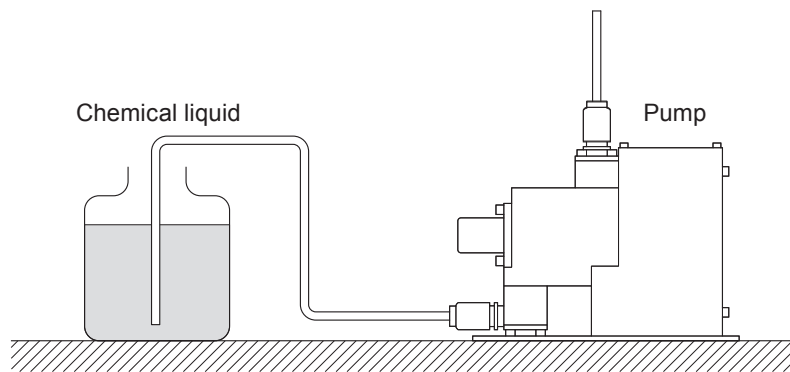

● Mounting direction

Always mount the pump with the outlet upward and the check valves upright. Otherwise, performance may be reduced.

● Anchoring

Fix the pump with four M4 mounting screws (with PW and SW).

Piping

Observe the following points during pipework.

● Pipe connection

Both inlet and outlet of the pump are provided with Flowell tube fittings. Secure every joint properly to eliminate any possibility of air ingress, or performance may be reduced.

● Fitting and Tube

Take account of corrosion and pressure resistance when selecting fittings and tubes.

● Pipe resistance

Keep a piping length shortest with the minimum number of bends.

Observe the following diagram.

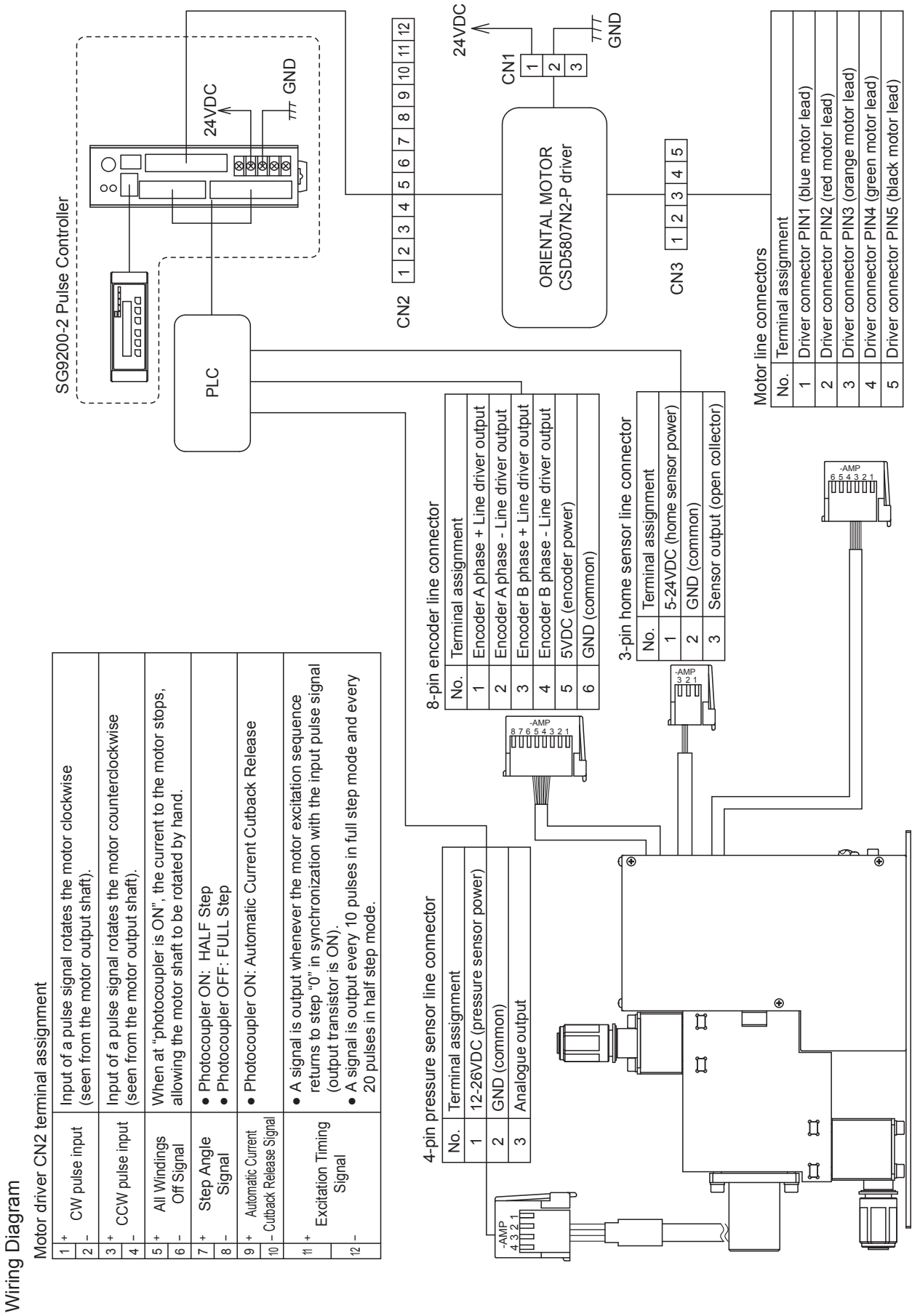

*When using an Oriental motor SG9200-2 Pulse Controller, consult its instruction manual as well.

Line connectors

See the table below for wiring with each device.

■ 3-pin home sensor line connector

Pin number	Terminal assignment
1 (brown)	5-24VDC (home sensor power)
2 (blue)	GND (common)
3 (black)	Sensor output (open collector)

■ 4-pin pressure sensor line connector

Pin number	Terminal assignment
1 (red)	12-26VDC (pressure sensor power)
2 (black)	GND (common)
3 (green)	Analogue output
4	N/A

■ 6-pin motor line connector

Pin number	Terminal assignment
1 (blue)	Motor lead
2 (red)	Motor lead
3 (orange)	Motor lead
4 (green)	Motor lead
5 (black)	Motor lead
6	N/A

■ 8-pin encoder line connector

Pin number	Terminal assignment
1 (white)	Encoder A phase + Line driver output
2 (white/black)	Encoder A phase - Line driver output
3 (green)	Encoder B phase + Line driver output
4 (green/black)	Encoder B phase - Line driver output
5 (red)	5VDC (encoder power)
6 (black)	GND (common)
7	N/A
8	N/A

Applicable motor drivers

See the table below for applicable ORIENTAL MOTOR's motor drivers.

Product name	Rated power voltage	Driver type	Pulse input type	Driver type	Cable	Attached connector
CRD5107PB	24VDC	Pulse-train input	1 pulse/ 2 pulse	PCB	<ul style="list-style-type: none"> • Cable set LCS04SD5 (0.6m) • Motor lead connector LCS5N06B (0.6m) LCS5N10B (1m) 	<ul style="list-style-type: none"> • MOREX 51103-0200 • MOREX 51103-1200 • MOREX 51103-0500 • MOREX 50351-8100 (contact)
CRD507-KD	24VDC	Built in	(I/O, RS485)	BOX	<Accessories> <ul style="list-style-type: none"> • In/out cable connector • Motor lead connector 	<ul style="list-style-type: none"> • PHOENIX CONTACT MC1,5/3-STF-3,5 power line connector
CSD5807N-P	24VDC	Pulse-train input	2 pulse	PCB	<ul style="list-style-type: none"> • Driver cable set LCS01CSK5 (0.6m) 	<ul style="list-style-type: none"> • AMP 171822-3 • AMP 1-171822-2 • AMP 171822-5
SD5107P3	24VDC	Pulse-train input	2 pulse	PCB	<ul style="list-style-type: none"> • Driver cable set LCS04SD5 (0.6m) • Motor lead connector LC5N06B (0.6m) LC5N10B (1m) 	<ul style="list-style-type: none"> • MOREX 51103-0200 • MOREX 51103-1200 • MOREX 51103-0500 • MOREX 50351-8100 (contact)
RKD507-A	100VAC	Pulse-train input	1 pulse/ 2 pulse	BOX	CC05PK5 5m motor cable CC10PK5 10m motor cable CC20PK5 20m motor cable	<ul style="list-style-type: none"> • Control signal in/out connector Case: MOREX 54311-1201 Connector: MOREX 54306-2019

Operation

This section describes pump operation. Observe instructions in this manual. See manufacturer's instruction manual for the motor driver.

Pump setting

First, program operation of the pump.

Pulse input & Motor rotation

The pump lets out liquid at the input of the CCW direction command pulse and takes in liquid at the input of the CW direction command pulse.

At factory default setting, the motor-driven cylinder (sensor dog) is at the origin where a home sensor output turns ON. Be sure the cylinder returns to the origin before operation. See the next page for detail.

■ Number of pulses & Flow volume

Number of input pulses	Calculated flow volume
1600	1.0ml/shot
4800	3.0ml/shot
8000	5.0ml/shot
12800	8.0ml/shot
19200	12.0ml/shot

■ Number of pulses & Flow rate

Number of input pulses per sec	Calculated flow rate
480 pps	0.3ml/sec
800 pps	0.5ml/sec
1600 pps	1.0ml/sec
3200 pps	2.0ml/sec

Return to origin

Program the origin return behaviour to ensure the motor-driven cylinder to come back to origin before operation every day. The behaviour should be different depending on whether the home sensor output is ON or OFF at an input of an origin return signal. See the programming chart below for detail.

■ Home sensor output is "OFF"

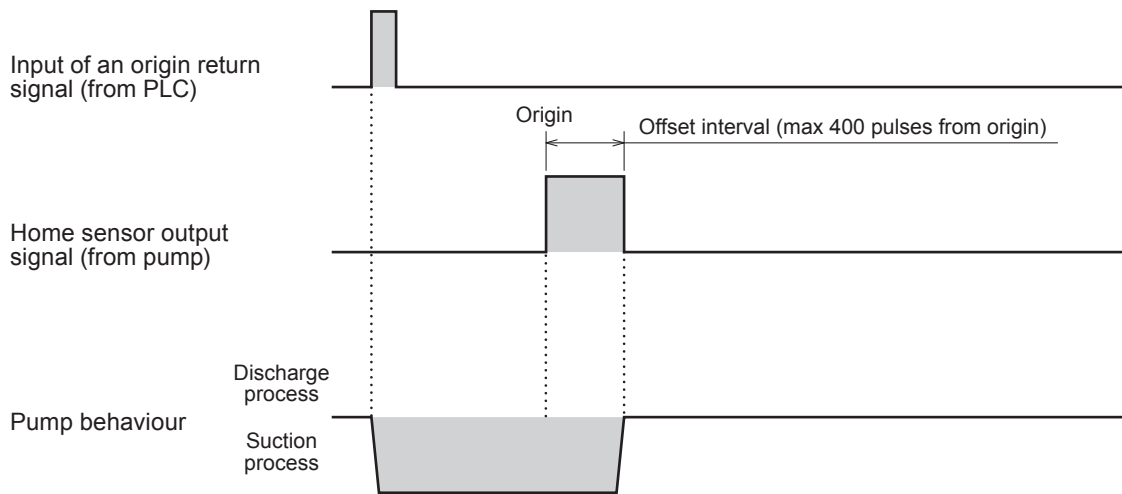

■ Home sensor output is "ON"

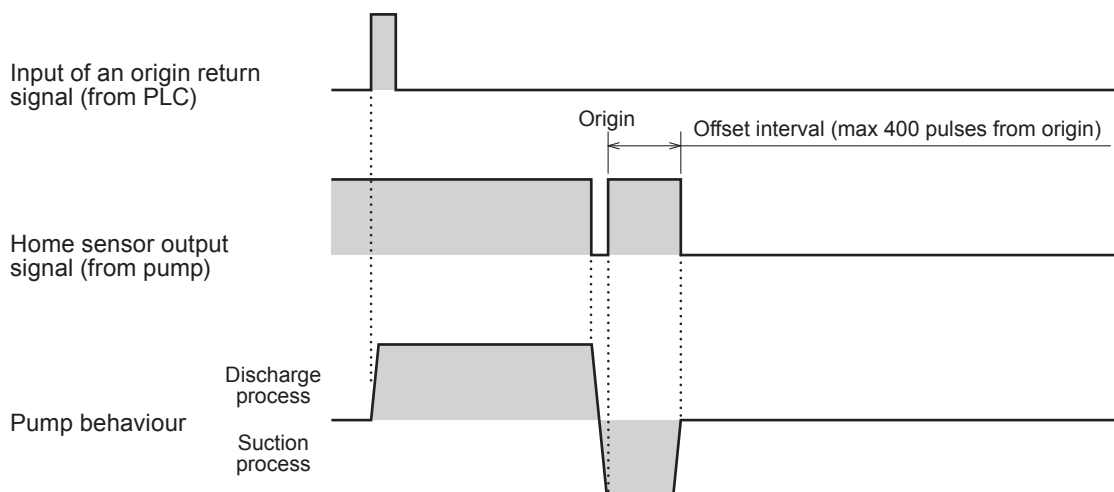

Operation programming

Operational behaviour can be programmed into two different control modes; Time-based control (via a pulse controller) and Flow-based control (via a pulse controller or user's PLC). In either mode, the pump runs through the routine of a discharge process, pause state, suction process and waiting state. See the following charts to program operation in individual modes.

NOTE

- The cylinder can contract beyond the origin for the offset interval (400 pulses below the origin). Do not exceed the limit.
- The motor may step out if the waiting time is too short. "Step out" means the motor rotates out of a specified step angle and number of pulses.
- The maximum discharge flow rate is 2ml/sec, however, discharge pressure may rise sharply depending on liquid viscosity and piping layout, and may overload the bellows. Observe the maximum discharge pressure.
- The maximum suction flow rate is 2ml/sec, however, suction pressure may fall sharply depending on liquid viscosity and piping layout, and may trigger cavitation. Observe the maximum suction pressure.

■ Time based control (when using an Oriental Motor SG9200-2 pulse controller)

An ORIENTAL MOTOR SG9200-2 pulse controller is needed for discharge-time control and an OMRON H3RN-1 Off-delay timer for suction-time control. A discharge process is made for a discharge time; a time period when the pump is receiving the discharge signal from the pulse controller, and a suction process starts as receiving a suction signal from the Off-delay timer. Provide with the pulse controller a pause time [T1] of 0.5 sec or more between the end of a discharge process and the start of a suction process and a waiting time (at least 1/2 of a set suction time) [T2] between the end of the suction process and the start of the next discharge process.

NOTE

Observe the formula below when determining a discharge flow rate and a discharge time. Or the pump may break:

$$\text{Discharge flow rate (see page 25)} \times \text{Discharge time} = 12.0\text{ml (max disch. capacity per shot: see page 25) or less}$$

<When a discharge flow rate \times a discharge time = 12.0ml>

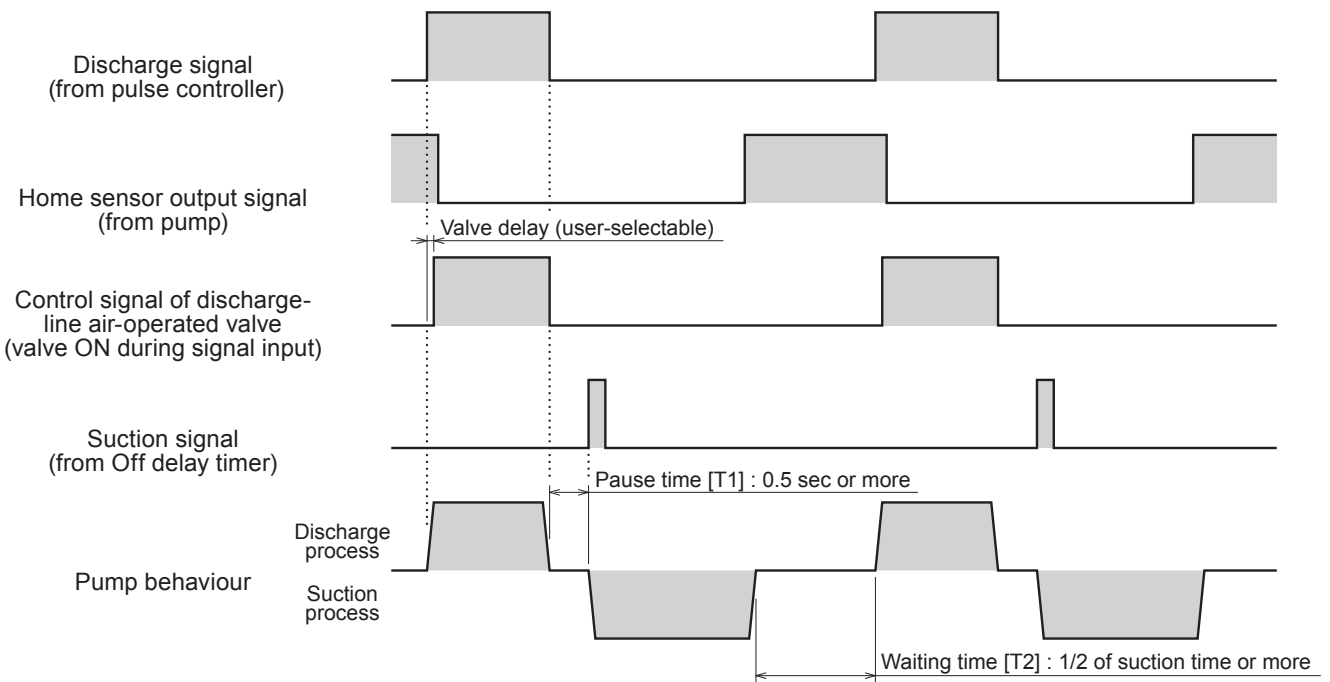

<When the same discharge flow rate \times a discharge time < 12.0ml>

A discharge process will become shorter.

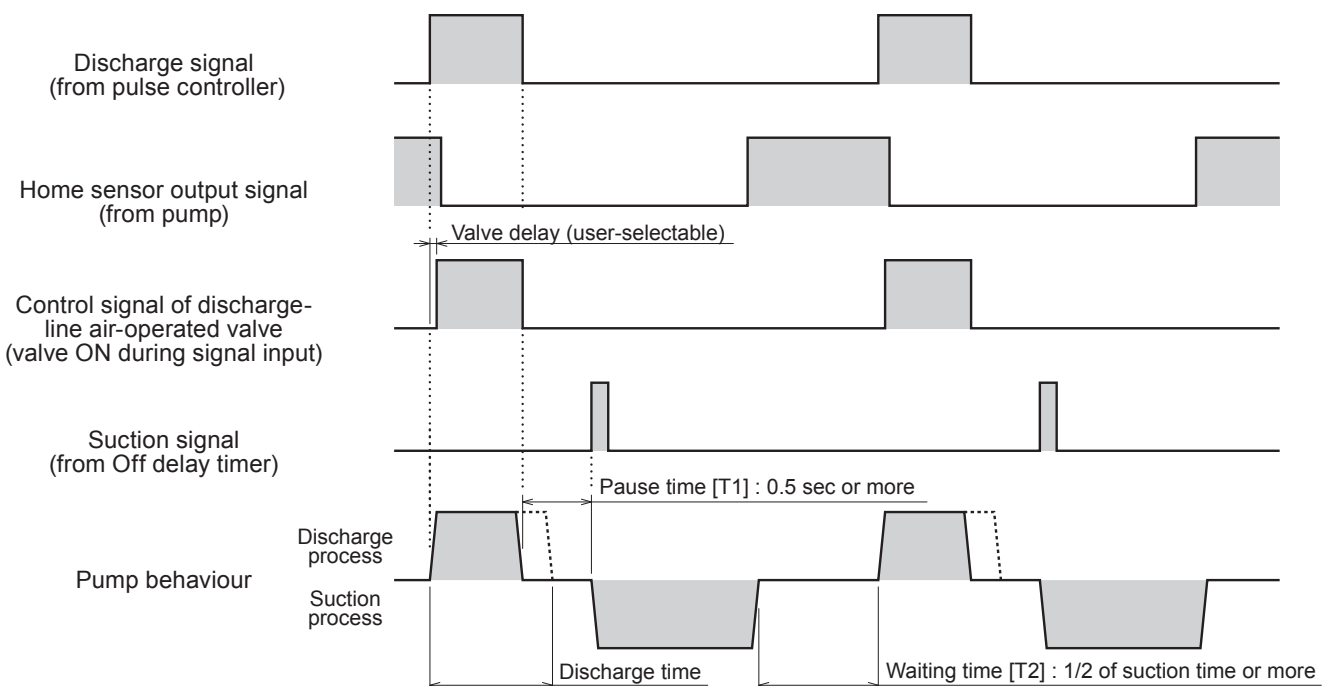

■ **Flow based control (when using a pulse signal as a start signal)**

Use the pulse controller or user's PLC to program a discharge and a suction flow rate as well as a pause time [T1] of 0.5 sec or more between the end of a discharge process and the start of a suction process and a waiting time (at least 1/2 of the time taken to finish suction process per set flow rate) [T2] between the end of the suction process and the start of the next discharge process. The programmed behaviour starts at an input of pulse signal.

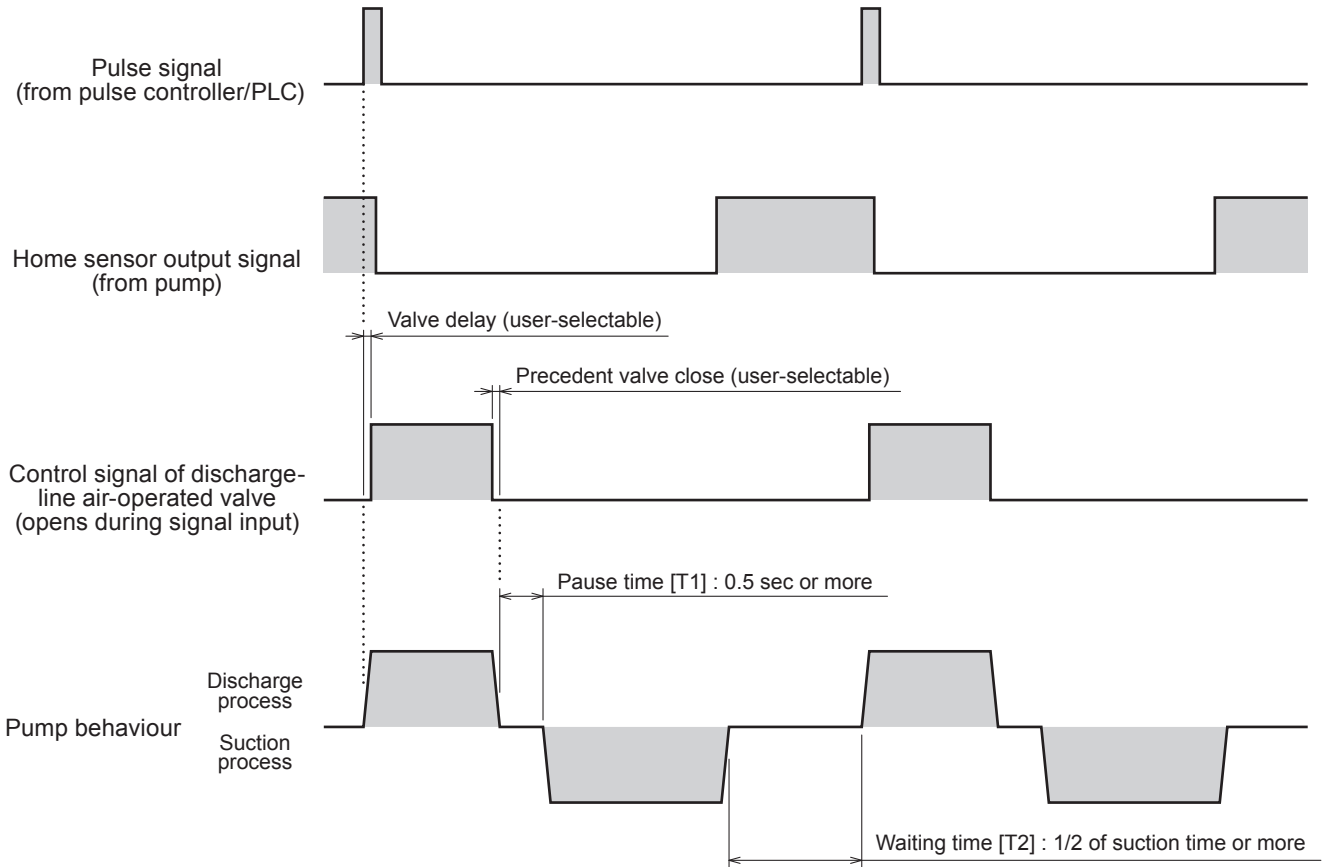

Pump operation

1 Filter flushing

Check that filter has been flushed in user's system.

NOTE

See manufacturer's manual for filter flushing.

2 Degassing

Eliminate air from the filter cartridge before operation. Air in a filter or a pipeline reduces a flow rate.

NOTE

See manufacturer's manual for degassing.

3 Open a suction and a discharge line fully.

NOTE

Do not close a valve on a suction line or a discharge line during operation. It may pose a leak or blow out the pump or a pipe.

4 Operation

Start operation along a programmed behaviour.

Maintenance

This section describes troubleshooting, inspection, specification and dimensions.

! Points to be observed

Observe the following points during maintenance work:

- Follow instructions in this manual for replacement of wear parts. Do not disassemble the pump. Contact us when repairs are needed.
- Always wear protective clothing such as an eye protection, chemical resistant gloves, a mask and a face shield during disassembly, assembly or maintenance work. The specific solution will dictate the degree of protection. Refer to MSDS precautions from the solution supplier.
- Solution in the discharge line may be under pressure. Release the pressure from the discharge line before disconnecting plumbing or disassembly of the pump to avoid solution spray.
- Risk of electrical shock. Be sure to turn off power to stop the pump and related devices before service is performed.

Troubleshooting

First check the following points. If the following measures do not help remove problems, contact your distributor.

States	Possible causes	Check items	Solutions
The pump does not run.	Faulty wiring	If wiring between the motor and motor driver is correct? See page 15.	• Correct wiring and resume operation.
	Power voltage is too low.	If a rated power voltage is applied to the motor driver? See page 17.	• Observe the rated voltage of the driver.
	An inapplicable motor driver is used.	If an applicable motor driver is used? See page 17.	• Use an applicable motor driver.
	Motor failure	If the motor steps out, abnormal noise and vibration are found?	• Check the motor. Replace as necessary.* If motor has failed, related electric devices may also have failed, so inclusive inspection is necessary.
Liquid can not be pumped up.	Air ingress through a suction line	Check for an air-ingress point.	• Seal the point by tightening a pipe joint.
	A failed O ring seal	Check for a leak point or a loose bolt.	• Tighten the bolt. Replace O ring as necessary.*
	Clogging in a pipe or the pump	Flush the pipe and the pump to determine clogging points.	• Determine a cause of clogging. Repair will be needed if the pump is clogged.*
	Malfunction of an air-operated valve	If supply air pressure is correct?	• Observe the rated supply air pressure.
		If a solenoid valve is damaged?	• Replace as necessary.
A ball valve is stuck on a valve seat.	If liquid flows back from the suction line end.	• Replace the check valve as necessary.*	

*Solutions marked with * are conducted by us.

States	Possible causes	Check items	Solutions
No home sensor signal	Faulty wiring	If the signal and power lines are connected in place? See page 15.	• Correct wiring and resume operation.
	Home sensor failure	Use a tester to check the voltage between GND and signal output terminals. The result should be: 0V at sensor "ON" Power voltage at sensor "OFF"	• Replace as necessary*
No pressure sensor signal	Faulty wiring	If the signal and power lines are connected in place? See page 15.	• Correct wiring and resume operation.
	Pressure sensor failure	Use a tester to check the voltage between GND and signal output terminals. The result should be: 1V when pump is stopped Above 1V when pump is running	• Replace as necessary*
No encoder signal	Faulty wiring	If the signal and power lines are connected in place? See page 15.	• Correct wiring and resume operation.
	Encoder failure	A counter does not work.	• Replace as necessary*

*Solutions marked with * are conducted by us.

Inspection

Perform daily inspection to keep pump performance and safety.

Daily inspection

Check for a leak or any other abnormality during operation. If you notice any abnormal condition, suspend operation immediately and inspect/solve problems according to "Troubleshooting".

Specification/Outer dimension

Specification

Information in this section is subject to change without notice.

■ Pump

Item	Spec
Max discharge capacity	12 [ml/shot]
Max discharge pressure*3&5	1.0 [MPa]
Max suction pressure	-0.05 [MPa]
Discharge flow rate*3	0.5-2.0 [ml/sec]
Suction flow rate*1	0.3-2.0 [ml/sec]
Resolution	0.01 [ml]
Discharge accuracy	±0.3 [%]F.S
Linearity*4	±4 [%]F.S
Allowable liquid viscosity	Max.10000 [mPa·s]
Number of pulses per discharge capacity*2	1600 [pulse/ml]
Ambient temperature	15-40 [°C]
Ambient humidity	30-60 [%RH]
Allowable liquid temperature	15-30 [°C]
Weight	3 [kg]

*1 The maximum suction flow rate is 2ml/sec, however, suction pressure may fall sharply depending on liquid viscosity and piping layout, and may trigger cavitation. Observe the maximum suction pressure.

*2 The number of pulses per discharge capacity is a reference value with half stepping (0.36° per pulse).

*3 Set the discharge flow rate not to exceed the max discharge pressure.

*4 When handling viscous liquid, linearity may reduce depending on piping layout.

*5 Do not close a valve on a suction line or a discharge line during operation. It may pose a leak or blow out the pump or a pipe.

■ Stepping motor

Items	Spec
Manufacturer	ORIENTAL MOTOR Co, Ltd.
Model	PK545-NB or equivalent
Maximum holding torque	0.23 N·m
Rated current	0.75 A/Phase
Step angle	0.72°
Insulation resistance	B class (130°C)

The above data is based on use of an ORIENTAL MOTOR CSD5807N2-P driver.

■ Encoder

Items	Spec
Manufacturer	Microtech Laboratory Inc.
Model	MGH-20-500-E
Supply voltage	5 VDC \pm 0.5
Consumption current	60 mA or below
Detection	Incremental
Number of output pulses	500
Output phase	2-phase (A and B)
Output type	Line driver

■ Home sensor

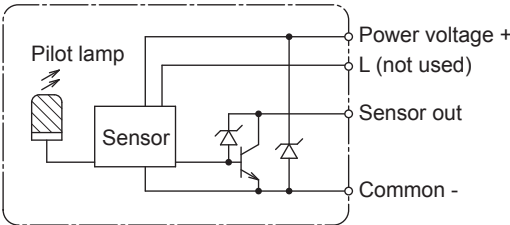
Items	Spec
Manufacturer	OMRON
Model	EE-SX670A
Supply voltage	5-24 VDC \pm 10%
Sensor logic	Normally open
Output type	Open collector
Output operation	<p>Dark-ON</p> 

■ Pressure sensor

Items	Spec
Manufacturer	PURERON JAPAN
Model	PC-515FL-1MPG-V-IWP4
Rated pressure	-0.1 - 1.0 MPa
Supply voltage	12-26 VDC
Output type	Analogue voltage
Output voltage	1-5 VDC
Accuracy	\pm 1.0% (F.S.)

Outer dimension

■ PDS-H115

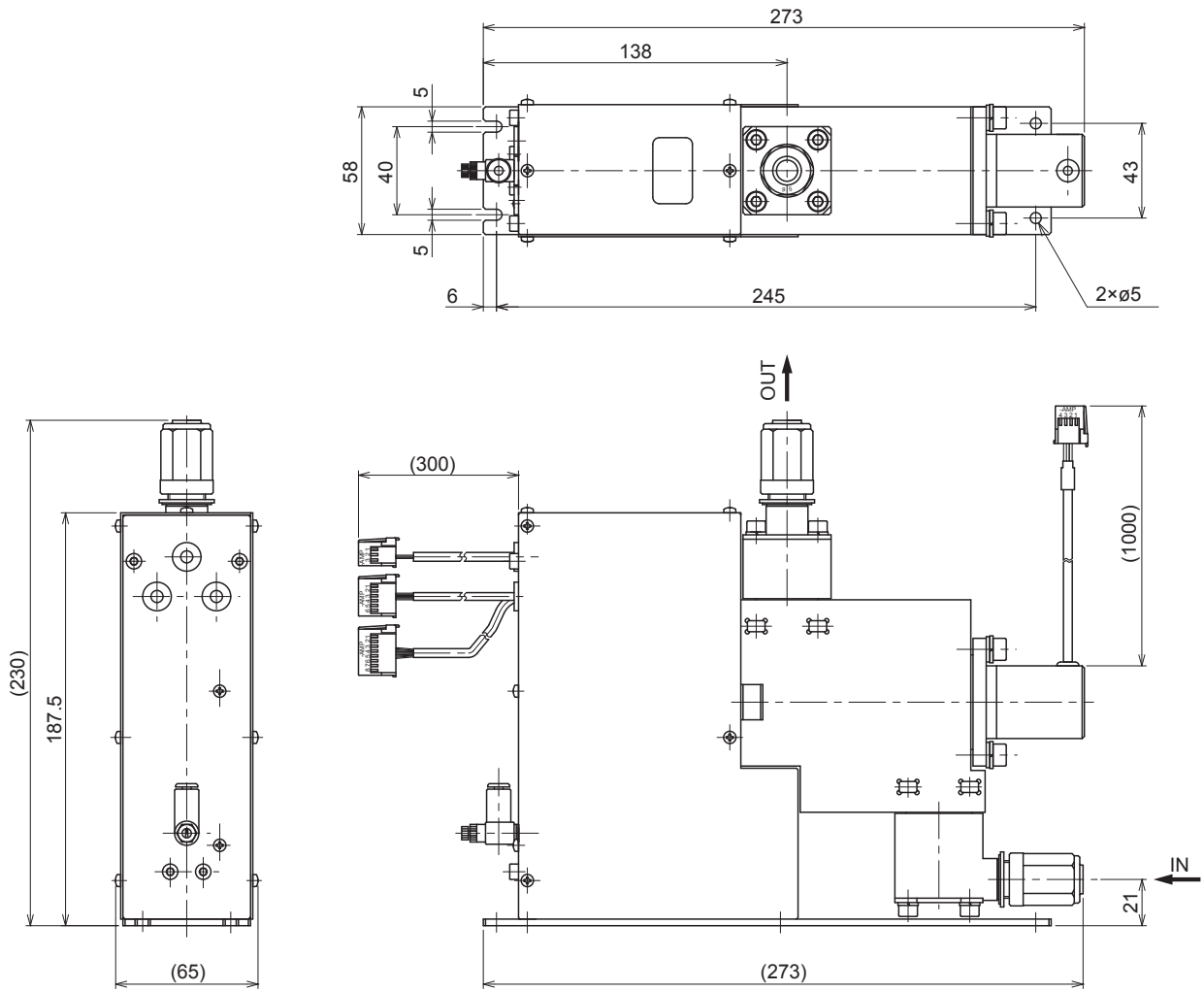

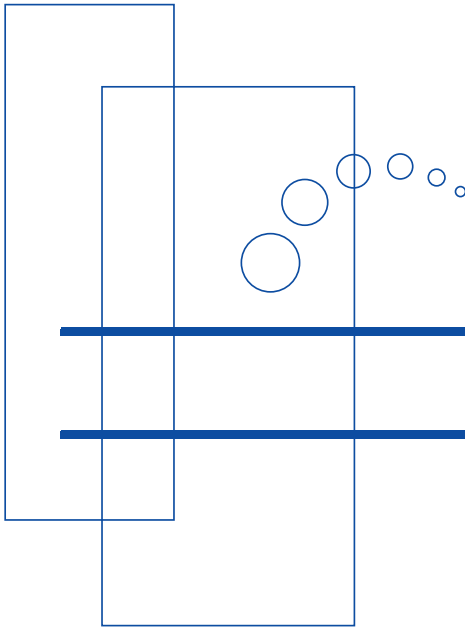

<http://www.iwakipumps.jp>

()Country codes

IWAKI CO.,LTD. 6-6 Kanda-Sudacho 2-chome Chiyoda-ku Tokyo 101-8558 Japan
TEL:(81)3 3254 2935 FAX:3 3252 8892

Australia	IWAKI Pumps Australia Pty. Ltd.	TEL:(61)2 9899 2411	FAX: 2 9899 2421	Italy	IWAKI Italia S.R.L.	TEL:(39)0444 371115	FAX: 0444 335350
Austria	IWAKI EUROPE GmbH	TEL:(49)2154 9254 0	FAX: 2154 9254 48	Korea	IWAKI Korea Co.,Ltd.	TEL:(82)2 2630 4800	FAX: 2 2630 4801
Belgium	IWAKI Belgium n.v.	TEL:(32)1367 0200	FAX: 1367 2030	Malaysia	IWAKIm Sdn. Bhd.	TEL:(60)3 7803 8807	FAX: 3 7803 4800
China	IWAKI Pumps (Shanghai) Co., Ltd.	TEL:(86)21 6272 7502	FAX: 21 6272 6929	Norway	IWAKI Norge AS	TEL:(47)23 38 49 00	FAX: 23 38 49 01
China	IWAKI Pumps (Guandong) Co., Ltd.	TEL:(86)750 3866228	FAX: 750 3866278	Singapore	IWAKI Singapore Pte. Ltd.	TEL:(65)6316 2028	FAX: 6316 3221
China	GFTZ IWAKI Engineering & Trading (Guangzhou)	TEL:(86)20 8435 0603	FAX: 20 8435 9181	Spain	IWAKI Iberica Pumps, S.A.	TEL:(34)943 630030	FAX: 943 628799
China	GFTZ IWAKI Engineering & Trading (Beijing)	TEL:(86)10 6442 7713	FAX: 10 6442 7712	Sweden	IWAKI Sverige AB	TEL:(46)8 511 72900	FAX: 8 511 72922
Denmark	IWAKI Nordic A/S	TEL:(45)48 24 2345	FAX: 48 24 2346	Switzerland	IWAKI (Schweiz) AG	TEL:(41)26 674 9300	FAX: 26 674 9302
Finland	IWAKI Suomi Oy	TEL:(358)9 2745810	FAX: 9 2742715	Taiwan	IWAKI Pumps Taiwan Co., Ltd.	TEL:(886)2 8227 6900	FAX: 2 8227 6818
France	IWAKI France S.A.	TEL:(33)1 69 63 33 70	FAX: 1 64 49 92 73	Taiwan	IWAKI Pumps Taiwan (Hsin-chu) Co., Ltd.	TEL:(886)3 573 5797	FAX: (886)3 573 5798
Germany	IWAKI EUROPE GmbH	TEL:(49)2154 9254 0	FAX: 2154 9254 48	Thailand	IWAKI (Thailand) Co.,Ltd.	TEL:(66)2 322 2471	FAX: 2 322 2477
Holland	IWAKI EUROPE NL Branch	TEL:(31)547 293 160	FAX: 547 292 332	U.K.	IWAKI Pumps (UK) LTD.	TEL:(44)1743 231363	FAX: 1743 366507
Hong Kong	IWAKI Pumps Co., Ltd.	TEL:(852)2 607 1168	FAX: 2 607 1000	U.S.A.	IWAKI AMERICA Inc.	TEL:(1)508 429 1440	FAX: 508 429 1386
Indonesia	IWAKI Singapore (Indonesia Branch)	TEL:(62)21 690 6606	FAX: 21 690 6612	Vietnam	IWAKI pumps Vietnam Co.,Ltd.	TEL:(84)613 933456	FAX: 613 933399