

IWAKI  
HI-CERA  
PUMPS



# Ultra-high precision valveless plunger pump

Fine ceramic plunger highly resistant to corrosion and abrasion

## Ultra-high precision mechanism

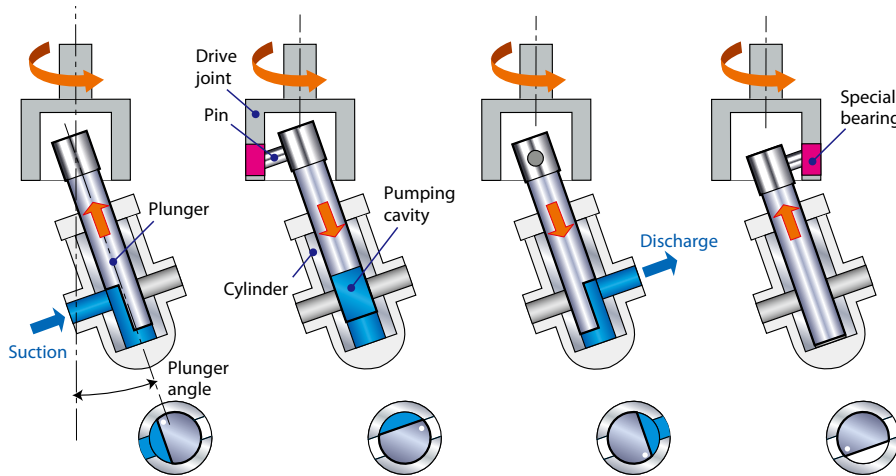

Suction process

With the pumping cavity facing the inlet, the plunger retracts and liquid is sucked into the cylinder.

End of suction process

The inlet closes when the pumping cavity passes over the inlet.

Discharge process

With the pumping cavity facing the outlet, the plunger moves forward and liquid is discharged from the cylinder.

End of discharge process

The outlet closes when the pumping cavity passes over the outlet.

The plunger is connected to the drive joint via a special bearing and pin. When the drive joint rotates, the plunger rotates and moves up and down inside the cylinder. The plunger angle determines how far down the cylinder the plunger moves while the driving joint rotates. This unique structure eliminates the need for the valve system normally employed in other pumps.



The Iwaki Hicera pump is a compact metering pump that employs a fine ceramic plunger. The unique valveless construction eliminates problems caused by clogging and jamming that commonly occur in conventional metering pumps. The precision micron-machining on the main ceramic parts ensures a high degree of discharge accuracy. The versatility of the Iwaki Hicera pump makes it ideal for micro-chemical feeding as well as high-viscosity liquid feeding.

## Ultra-high precision dosing of $\pm 0.5\%$ <sup>Note</sup>

Capable of ultra-high precision dosing at a micro discharge capacity. Simple adjustment of the discharge capacity by changing the angle of the pump head.

Note: Using the stepping motor (non-standard order) achieves a precision of  $\pm 0.5\%$ . Contact us for details.

## Max. 20,000 mPa·s high viscous liquid transfer

The unique valveless structure enables the smooth metering transfer of high viscous liquid at a maximum of 20,000 mPa·s.

- Discharge accuracy may deteriorate when handling 500 mPa·s or more. If the liquid to be handled contains slurry, make sure to check the properties of the liquid. Contact us for details.
- Contact us for details about pumping highly viscous liquids (20,000 mPa·s or more).

## Discharge into a vacuum and suction from high pressure sources

Because there are no suction / discharge valves, the pump is able to discharge directly into a vacuum (negative pressure) without the need for electromagnetic valves. Maintains a constant flow even if the suction / discharge pressure fluctuates.

## Higher corrosion resistance—Perfect for handling a variety of liquids

Ceramics and PTFE resins are used on the wetted surface, lending greater resistance when pumping acid, alkaline, organic solvents, and other liquids.

## Compact design—Ideal for built-in applications

The compact and light Hicera pumps can be installed in both vertical and horizontal orientations, making them ideal for built-in applications. The reversible motor direction allows you to reverse the flow without needing to change the piping.

## Original structure—Airlock free

This pump enables air to be automatically discharged from the outlet, thereby preventing problems caused by airlock.

- Depending on the installation conditions or the liquid being handled, there are times air cannot be discharged smoothly. Contact us for more details.



V-05



V-10



V-15

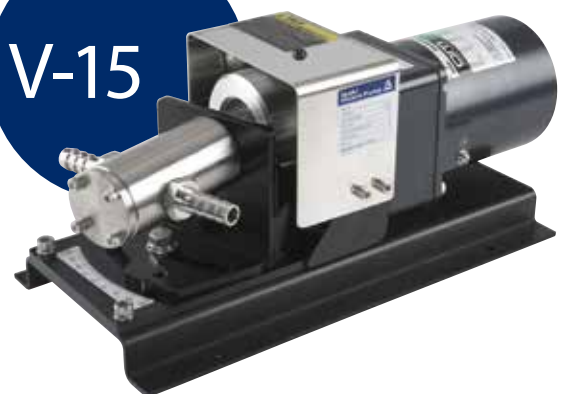

# The main part which was processed precisely in micron order

## Construction

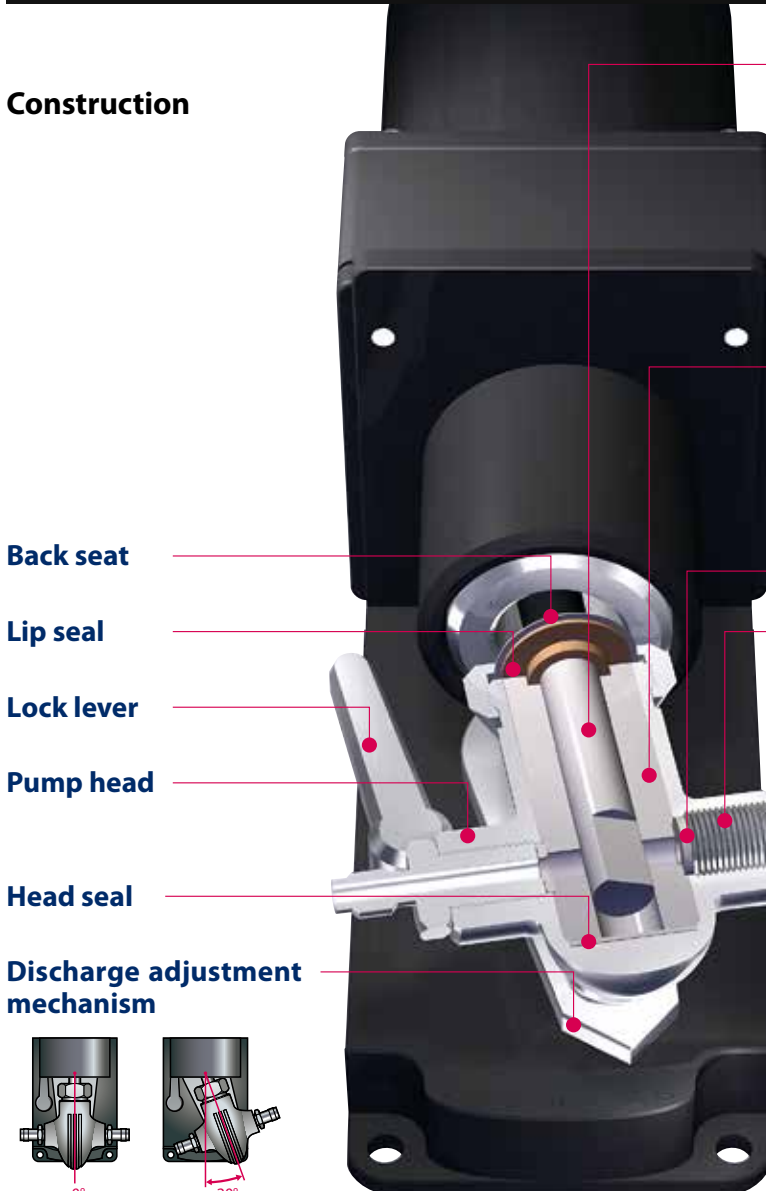

### Plunger

The plunger is processed using micron order high-precision technology, leading to a higher degree of discharge precision. It is made of SiC or alumina ceramic (Al<sub>2</sub>O<sub>3</sub>).



### Cylinder

Like the plunger, the cylinder is also processed using high-precision technology.



### Joint seal

### Tube joint

We offer a standard stainless steel hose joint (SUS316) and a stainless steel female adapter (SUS) that can be connected to commercial tube fitting.

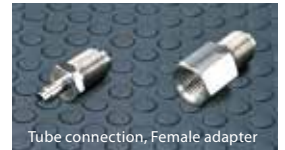

Back seat

Lip seal

Lock lever

Pump head

Head seal

Discharge adjustment mechanism

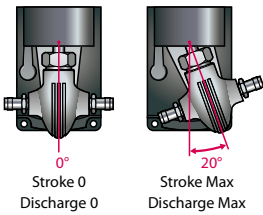

## Materials

Model	V-05	V-10		V-15	
Pump head	SCS14			SUS304	
Plunger	SiC	SiC	Al <sub>2</sub> O <sub>3</sub>	SiC	Al <sub>2</sub> O <sub>3</sub>
Cylinder	SiC	SiC	Al <sub>2</sub> O <sub>3</sub>	SiC	Al <sub>2</sub> O <sub>3</sub>
Head seal	PTFE				
Back seal	PTFE				
Tube joint	SUS316				
Joint seal	PTFE				
Lip seal	PTFE				

## Identification

V - 05 S L P 1 A 1 - X

Standard combination	Plunger diameter	Material (Plunger/Cylinder material)	Pump head material	Cleaning port
05SL	05: 5mm	S: SiC/SiC	L: SCS14	—: Unavailable
05SLP			Investment casting	P: Available
10AL	10: 10mm	A: Al <sub>2</sub> O <sub>3</sub> /Al <sub>2</sub> O <sub>3</sub>	—: Unavailable	—: Unavailable
10ALP			L: SCS14	P: Available
10SL		S: SiC/SiC	Investment casting	—: Unavailable
10SLP			P: Available	
15AS	15: 15mm	A: Al <sub>2</sub> O <sub>3</sub> /Al <sub>2</sub> O <sub>3</sub>	—: Unavailable	—: Unavailable
15ASP			S: SUS304	P: Available
15SS		S: SiC/SiC	Cutting product	—: Unavailable
15SSP			P: Available	

The table above lists the plunger diameter, plunger / cylinder materials, and pump head materials. It also indicates whether a cleaning port is equipped.

### Power voltage

- 1: AC100V single phase
- 2: AC200V single phase
- 3: AC200V three phase
- 4: AC110 - 115V single phase
- 5: AC220 - 230V single phase

### Gear ratio (Adaptation pump)

- A: 1/150 (V-05, V-10)
- B: 1/75 (V-05, V-10)
- C: 1/30 (V-10)

### Joint

- 1: Ø6 SUS hose
- 2: Ø10 SUS hose
- 3: Ø13 SUS hose
- 4: Rc1/4 SUS Female adapter
- 5: Rc3/8 SUS Female adapter

### Special specifications

X: Special specifications  
Special specifications are required for non-standard motors. Contact us for details about these specifications.

### (Adaptation pump)

- E: 1/7.5 (V-10, V-15)
- G: 1/3 (V-10, V-15)

### (Adaptation pump)

- (V-05, V-10 Gear ratio 1/150 - 1/15)
- (V-10 Gear ratio 1/7.5 - 1/3)
- (V-15)
- (V-05, V-10)
- (V-15)

### Specifications (50/60Hz)

Model <sup>Note1</sup>	Gear ratio	No. of revolution <sup>Note2</sup> rpm	Max. discharge capacity mL/min	Max. discharge pressure MPa	Tube joint <sup>Note3</sup> mm	Standard motor <sup>Note4</sup>	Mass kg
V-05SL1A1	1/150	9/11	1.6/1.9	0.7	Ø6 SUS316 made hose joint type	Induction motor 15W	2.3
V-05SL1B1	1/75	19/23	3.3/4.0				
V-10□L1A1	1/150	9/11	6.0/7.0	0.7	Ø6 SUS316 made hose joint type	Induction motor 15W	2.3
V-10□L1C1	1/30	48/58	33/40				
V-10□L2E1	1/7.5	193/232	135/163	0.6	Ø10 SUS316 made hose joint type	Induction motor 25W	3.0
V-10□L2G1	1/3	483/580	338/409				
V-15□S3E1	1/7.5	193/232	559/673	0.5	Ø13 SUS316 made hose joint type	Induction motor 40W	8.0
V-15□S3G1	1/3	483/580	1400/1682				

Note1: The model code is entered in the □ box (A: Al<sub>2</sub>O<sub>3</sub>, S: SiC).

Note2: The number of revolutions varies depending on how the pump is loaded.

Note3: Stainless steel (SUS) female adapters as well as a standard tube joint can be used (V-05, V-10: Rc 1/4, V-15: Rc 3/8).

Note4: Other motors can be used to accommodate non-standard orders. Contact us for details.

• The performance values in the table represent the values for when clear water is pumped at an ambient temperature.

• Discharge capacity per revolution: approx. 0.17 mL/rev for V-05, approx. 0.70 mL/rev for V-10, approx. 2.90 mL/rev for V-15 (swing angle of 20 degrees)

• The suction ability of the pump is more than 4 meters. Note that suction ability varies depending on the liquid that is used.

• Be sure to clean the inside of the pump when pumping crystallized or adhesive liquids.

### Performance graph

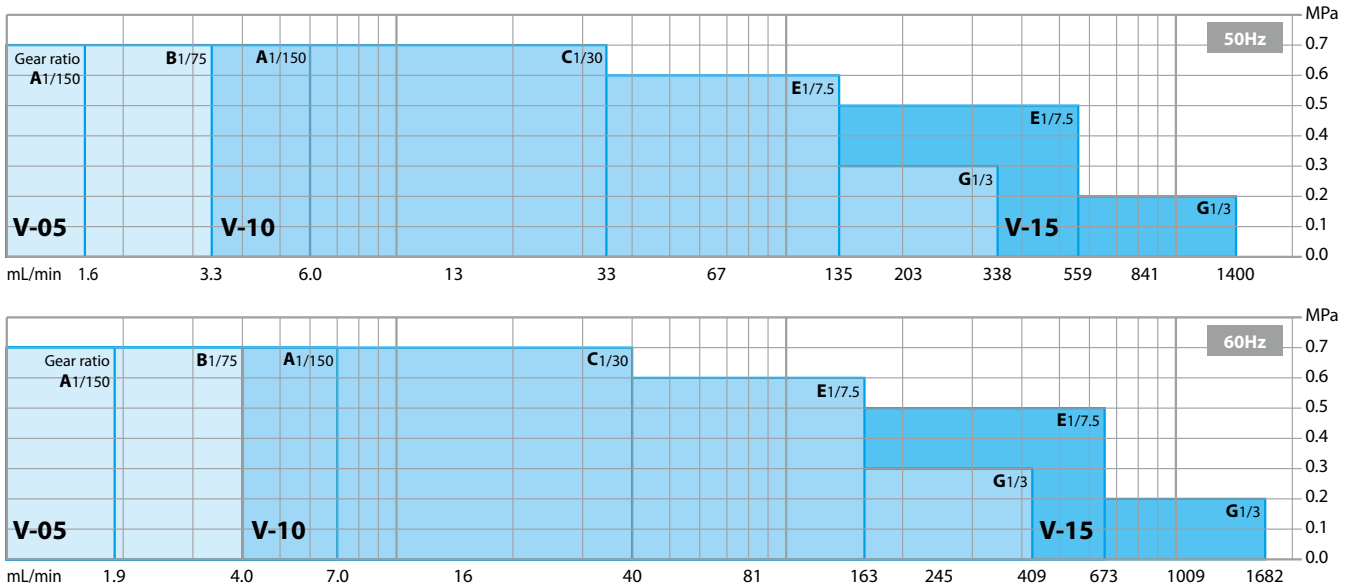

### Dimensions (mm)

V-05, V-10

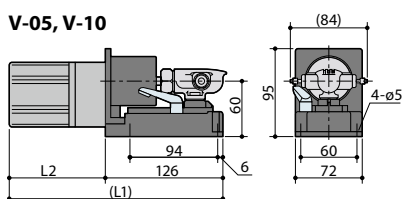

Model	Standard motor	L1	L2
V-05	15W	233	107
V-10 L1	15W	233	107
V-10 L2	25W	245	119

V-15

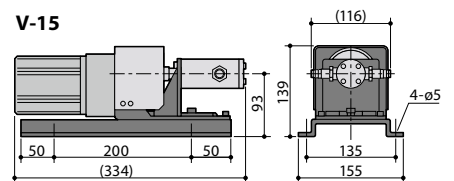



# Available for wide applications

The excellent discharge precision and superb durability of the Hicera pump makes it ideal for use in a wide range of fields. The pump's versatility enables it to be used in a variety of different processes. Whether it is mounted in other devices or used by OEMs, the Hicera pump can be adapted to fit the needs and specifications of each application.

## Applications

### Fuel-cell

Reformed water pump

### Secondary cell

Filling and pumping the electrolyte solutions of a lithium cell  
Injection of gel-like liquid at a constant rate

### Medical devices

Clinical laboratory devices  
Artificial dialyzers

### Cleaning equipment

Injection of detergent / rinsing chemical

### Paper manufacturing

Injection of paper strength additives at a constant rate  
Injection of dye at a constant rate  
Injection of slime control agent

### Food equipment

Transfer of food additives at a constant rate  
Filling of soups  
Injection of flavor liquids  
Sampling  
Injection of bactericides

### Capacitor

Injection of phosphoric acid liquid

### Liquid waste treatment facility

Injection of polymer flocculants / slaked limes

## Special specification examples

### Specifications for special motors

#### Stepping motor type

Allows for high precision injection at the ultra-precision level.  
(Repeatability  $\pm 0.5\%$ )



#### Enhanced safety explosion-proof motor type

This type can be used for volatile and flammable drug solutions.  
• Explosion-proof motors can also be used.



#### Speed control motor type (Equipped with a controller)

The variable volume controller located at the top of the motor makes it easy to control the number of the revolutions.



#### Sanitary type

This type consists of a ferrule joint and a stainless-steel base. It can be used to sample beer and other beverages.



Special specifications are required for non-standard motors. Contact us for details about these specifications.

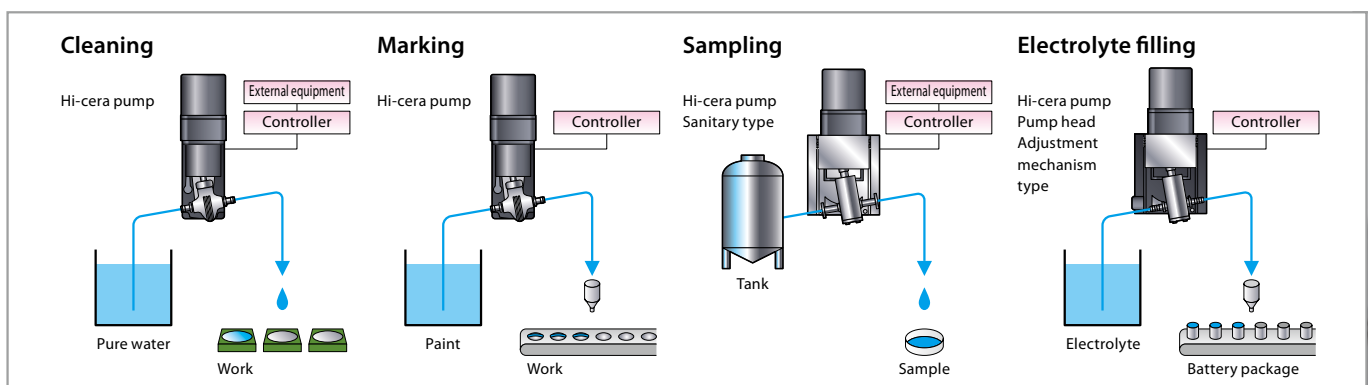

### Secondary / lithium cell

#### Pump equipped with a pump head adjustment mechanism

This type has an adjustable knob used to change the swing angle of the pump head, allowing for the accurate adjustment of the stroke length.

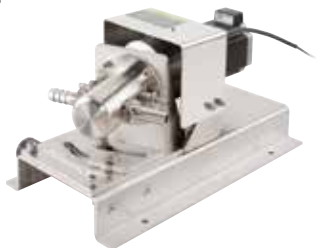

### Dialyzer

#### Pump for artificial dialysis

This type consists of a PVDF pump head and 24 VDC stepping motor. It is mounted on an artificial dialyzer for use as a drainage pump or dialysate pump.



V-15 for drug solution / dialysate

### Household fuel-cell

#### Compact pump type for fuel cells

This type consists of a PVDF pump head and 24 VDC stepping motor. It is mounted on household use fuel-cells, such as ENE-FARM, and used as a pump for reformed water.



V-07AF3



V-10 for drainage / dialysate

### Analyzer

#### Pump for analyzer

This pump is mounted on hemanalysis instruments.



V-07AEP06



V-10 for drainage / dialysate



V-07AFP06 for drainage / dialysate



**IWAKI CO., LTD.** 6-6 Kanda-Sudacho 2-chome Chiyoda-ku Tokyo 101-8558 Japan TEL : (81)3 3254 2935 FAX : 3 3252 8892

IWAKI has global net work.  
Please find your distributor location at

[www.iwakupumps.jp](http://www.iwakupumps.jp)

European office : <b>IWAKI Europe GmbH</b>	TEL: (49)2154 9254 0	FAX: 2154 9254 48	U.S.A. : <b>IWAKI America Inc.</b>	TEL: (1)508 429 1440	FAX: 508 429 1386
Germany : <b>IWAKI Europe GmbH</b>	TEL: (49)2154 9254 50	FAX: 2154 9254 55	Argentina : <b>IWAKI America Inc. (Argentina Branch)</b>	TEL: (54)11 4745 4116	
Holland : <b>IWAKI Europe GmbH (Netherlands Branch)</b>	TEL: (31)74 2420011	FAX: (49)2154 925448	Singapore : <b>IWAKI Singapore Pte Ltd.</b>	TEL: (65)6316 2028	FAX: 6316 3221
Italy : <b>IWAKI Europe GmbH (Italy Branch)</b>	TEL: (39)0444 371115	FAX: 0444 335350	Indonesia : <b>IWAKI Singapore (Indonesia Office)</b>	TEL: (62)21 6906606	FAX: 21 6906612
Spain : <b>IWAKI Europe GmbH (Spain Branch)</b>	TEL: (34)93 37 70 198	FAX: 93 47 40 991	Malaysia : <b>IWAKIm Sdn. Bhd.</b>	TEL: (60)3 7803 8807	FAX: 3 7803 4800
Belgium : <b>IWAKI Belgium N.V.</b>	TEL: (32)13 67 02 00	FAX: 13 67 20 30	Australia : <b>IWAKI Pumps Australia Pty Ltd.</b>	TEL: (61)2 9899 2411	FAX: 2 9899 2421
Denmark : <b>IWAKI Nordic A/S</b>	TEL: (45)48 24 2345	FAX: 48 24 2346	Hong Kong : <b>IWAKI Pumps Co., Ltd.</b>	TEL: (852)2607 1168	FAX: 2607 1000
Finland : <b>IWAKI Suomi Oy</b>	TEL: (358)9 2745810	FAX: 9 2742715	China : <b>GFTZ IWAKI Engineering &amp; Trading Co., Ltd.</b>	TEL: (86)20 84350603	FAX: 20 84359181
France : <b>IWAKI France S.A.</b>	TEL: (33)1 69 63 33 70	FAX: 1 64 49 92 73	Korea : <b>IWAKI Pumps (Shanghai) Co., Ltd.</b>	TEL: (86)21 6272 7502	FAX: 21 6272 6929
Norway : <b>IWAKI Norge AS</b>	TEL: (47)23 38 49 00	FAX: 23 38 49 01	Taiwan : <b>IWAKI Korea Co.,Ltd.</b>	TEL: (82)2 2630 4800	FAX: 2 2630 4801
Sweden : <b>IWAKI Sverige AB</b>	TEL: (46)8 511 72900	FAX: 8 511 72922	Thailand : <b>IWAKI Pumps Taiwan Co., Ltd.</b>	TEL: (886)2 8227 6900	FAX: 2 8227 6818
U.K. : <b>IWAKI Pumps (UK) Ltd.</b>	TEL: (44)1743 231363	FAX: 1743 366507	Vietnam : <b>IWAKI (Thailand) Co.,Ltd.</b>	TEL: (66)2 322 2471	FAX: 2 322 2477
		( ) Country codes	Vietnam : <b>IWAKI Pumps Vietnam Co., Ltd.</b>	TEL: (84)613 933456	FAX: 613 933399

 **Caution for safety use:**  
Before use of pump, read instruction manual carefully to use the product correctly.

Actual pumps may differ from the photos.  
Specifications and dimensions are subject to change without prior notice. For further details please contact us.

 **Legal attention related to export.**

Our products and/or parts of products fall in the category of goods contained in control list of international regime for export control. Please be reminded that export license could be required when products are exported due to export control regulations of countries.

The posting and copying from this catalogue without permission is not accepted firmly.